

VOLUME III

Varsity Team Program Features

For Varsity Scout Teams and Venture Patrols

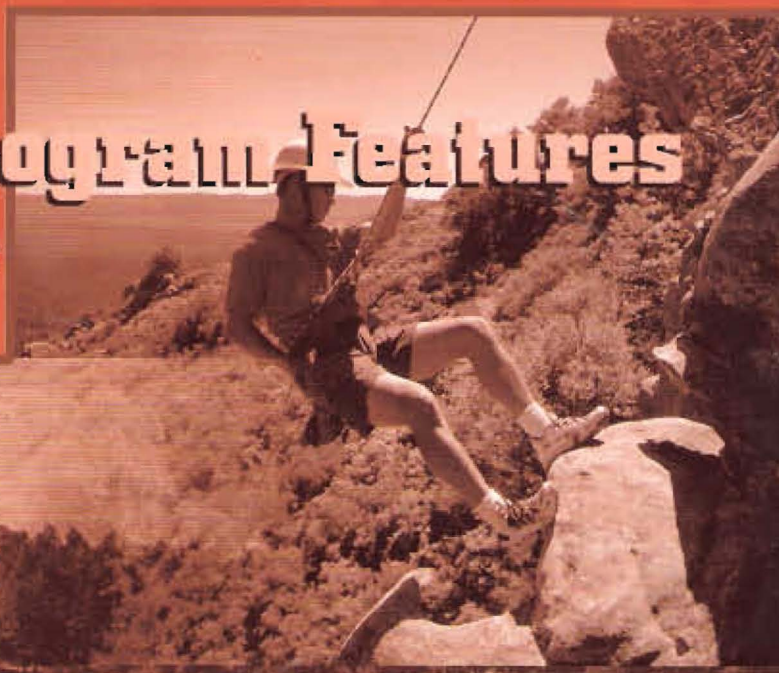

BOY SCOUTS  OF AMERICA®

VARSIITY TEAM PROGRAM FEATURES VOLUME III

For Varsity Scout Teams and Venture Patrols

CONTENTS

Planning the Varsity Scout Program	5
Varsity Scout Team Activity Planning Worksheet	7
Varsity Scout Team Meeting Plan Worksheet	8
Annual Varsity Scout Team Planning Chart	9
Soccer	10
Softball	28
Survival	44
Swimming	58
Tennis	76
Triathlon	90
Volleyball	106
Waterskiing	120
Whitewater Canoeing	144

VOLUME I COVERS THE FOLLOWING PROGRAM FEATURES:

Backpacking
Basketball
Bowling
Canoe Camping
Caving
Cross-Country Skiing
Cycling
Discovering America
Fishing

VOLUME II COVERS THE FOLLOWING PROGRAM FEATURES:

Freestyle Biking
Frontiersman
Mechanics
Operation On-Target
Orienteering
Rock Climbing and Rappelling
Roller Hockey
Shooting Sports
Snow Camping

PLANNING THE VARSITY SCOUT PROGRAM

An exciting Varsity Scout program does not just happen. It takes careful planning. The three volumes of *Varsity Scout Program Features* are essential in providing program ideas and in offering basic instruction in 27 different sports and high adventure activities. Each program feature offers conditioning, training, and basic instruction that will progress the team to a proficient skill level over a three month period.

The following pages outline the steps in successful program planning. The three volumes of program features and copies of the *Varsity Scout Guidebook* should provide all the tools you will need to plan a successful year for your Varsity Scout team.

A crucial ingredient to program planning is the annual program planning clinic, which is outlined in chapter 15 of the *Varsity Scout Guidebook*. The six steps in this section will also be helpful in effective program planning.

Once the leadership team has selected the program features for the new year, the team must then incorporate all five fields of emphasis into each program feature. Ideas are listed at the beginning of each program feature, and you are limited only by your imagination for other ideas. It is the responsibility of each program manager to make sure his field of emphasis is planned and carried out.

Upon completion of a program feature, team members may be awarded an activity pin to acknowledge their achievements, as well as the Varsity Scout letter or bar.

STEP 1: PREPARATION

Prior to conducting the team's annual program planning clinic, determine the resources available to the team.

- The physical facilities of your chartered organization and community that can be utilized
- The talents of the Varsity Scout parents
- The community resources available to the team such as sports leagues and outdoor facilities

If not already done, you will need to:

- Elect or appoint the team captain.
- Appoint program managers.
- Elect squad leaders.
- Gather calendars for schools, religious organizations, community holidays, and council and district Scouting activities. Do not forget personal dates and holidays.
- Conduct a Varsity Scout Team Resource Survey.
- Set the date and location for the team's annual program planning clinic.

STEP 2: CONDUCT THE TEAM'S ANNUAL PLANNING CLINIC

Chapter 15 of the *Varsity Scout Guidebook* is devoted to the planning the team program. This should be a fun, team-building experience that will set the tone for the new year, and a high expectation of exciting things to come.

STEP 3: SHARE THE PLAN

The team's annual program is presented to the team committee for its approval and support. The team committee chair assigns responsibilities to committee members who are program advisers to provide support to the program managers of the five fields of emphasis. If for some reason the committee cannot provide the needed support for an activity, outside resources should be considered and secured.

After receiving the team committee approval, with any modifications necessary, the team's annual program is published and provided to Scouts, families, and the chartered organization.

It is recommended that a parent's night be held to outline the team's annual program of events.

STEP 4: QUARTERLY PROGRAM DETAILING

- On a quarterly basis, the team leaders meet to detail the upcoming quarter.
- The Coach and captain develop the agenda for this meeting.
- The captain conducts the meeting with assistance from the Coach.
- Specific assignments are given to each program manager.
- A description of activities for the next quarter is entered on an activity worksheet. Program managers note specific assignments involving them. They request specific help from team members and the program adviser.

STEP 5: MONTHLY PROGRAM DETAILING

- The Coach, captain, program managers, and squad leaders meet on a monthly basis to finalize the coming month's meeting.
- The Coach and captain develop the agenda for this meeting.
- Activity worksheets are completed.
- Program managers verify that everything is ready for the month's activity.

STEP 6: WEEKLY CHECKUP

Two or three days prior to the meeting, the Coach or captain should check with each program manager for last minute assistance.

By following these planning steps, the Varsity Scout program will be well-received by the youth members. Be sure to include all five program fields of emphasis during each quarter. The team committee should devote a portion of the monthly meeting to securing committee member support for the team program and program managers.

Varsity Scout Team Activity Planning Worksheet

Activity: _____ Program manager _____

Team committee member/consultant _____

Place: _____ Date: _____

Team captain's comments: _____

Follow-up: _____

(Filled in by program manager)

Plan the activity. (Meet with your team committee member/consultant; make the plan.)

What needs to be accomplished? _____

Identify needs and resources.

Equipment and facilities needed _____

Determine payment plan for team members. _____

Number of people required _____

Task to Be Done

Assigned To

Follow-up. At additional meetings and through personal contacts, follow up on all assignments until you are sure that everything is ready. If the going gets rough, call on your Coach for help.

Carry out the plan. Just before the activity, double-check all arrangements. Conduct the activity to the best of your ability, using your supervisor as a resource.

Inform others. Give a copy of the plan to the team captain, program manager, team committee member, and Coach.

Varsity Scout Team Meeting Plan Worksheet

Feature _____

Meeting location _____

Date _____ Time _____

Activity	Description	Person Responsible	Time
Warm-up (Preopening) <ul style="list-style-type: none"> • Early arrival activity • Set up meeting room 			
Opening <ul style="list-style-type: none"> • Ceremony or song • Welcome • Announcements 			
Team Business <ul style="list-style-type: none"> • Reports • Assignments • High Adventure/Sports • Service • Personal Development • Special Programs and Events • Squad events • Other reports 			
Skills Instruction <ul style="list-style-type: none"> • Squad meetings • Advancement work • Practice time • Guest specialist/consultant • Contest or game • Special activity 			
Closing <ul style="list-style-type: none"> • Coach's Corner • Quiet song • Closing ceremony 			
Wrap-up <ul style="list-style-type: none"> • Evaluate meeting • Cleanup 			

Annual Varsity Scout Team Planning Chart

Quarter	Program Feature	Advancement	High Adventure/ Sports	Personal Development	Service	Special Programs and Events
1st September October November						
2nd December January February						
3rd March April May						
4th June July August						

SOCCER CONTENTS

Background	11
Program Fields of Emphasis	12
Condensed Rules of Soccer	13
Soccer Practice	13
Warm up and Conditioning Exercises	14
Skills Development Drills	15
Review the Rules	22
Scrimmage and Practice Games	23
Coaching League Games	24
Prevention and Care of Injuries	25
Glossary of Soccer Terms	26

SOCCKER

BACKGROUND



Soccer is a sport that began more than 3,000 years ago. There are ancient written accounts and graphic illustrations of Chinese soldiers kicking a ball made of leather and stuffed with animal hair.

The ancient Greeks and Romans played the game. As the Roman Empire grew, so did the game. From those ancient days to today's professional leagues the emphasis has been "win, not lose."

The Soccer chapter introduces you to this fast-moving Olympic sport. Explained in the chapter are the field of play, player positions, and condensed rules of the game. Topics also covered are conditioning exercises, drills for development of skills, team talk, and practice games that reinforce the skills learning.

Varsity soccer should be played for fun. The game is easy to play. All that is needed are two teams, a ball, and a flat piece of ground.

The object of the sport is to kick the ball into the opposing team's goal.

Varsity teams are encouraged to participate in soccer leagues found in most communities. These leagues may be operated by church associations, park departments, the YMCA, or sports associations.

The basic rules for all are similar. The number of players, field size, and periods of play may vary slightly, depending on your location. Varsity teams participating in these leagues abide by the league rules.

The Federation Internationale de Football Association (FIFA), an association of countries that play soccer, establishes the rules of games played worldwide.

The United States Soccer Federation (USSF) is a participating member of FIFA and serves as a resource for community leagues. Perhaps there are no community leagues in which Varsity team can participate. This chapter will help your team and other Varsity teams in your council learn the basics of soccer and, if necessary, establish a soccer league for Varsity soccer teams.

Soccer is a simple game. Two teams composed of an equal number of players try to put the ball into one of two goals placed at each end of the field without using the hands or arms. The team having made the most goals at the end of the game is the winner.

Soccer games have two halves of 20 to 40 minutes each (regulation games have 45-minute halves).

You won't need a lot of equipment to play soccer. Shirt, shorts, and sneakers or soccer shoes are worn by

team members. Usually team members wear a distinctive color shirt that identifies the team. The team goalkeeper must wear different colors than the other members of the team.

Three officials work each game. The referee is the only official on the field and is in charge. All the referee's decisions are final. The two other officials are linesmen. The linesmen work up and down the touchline and assist the referee by indicating which team will have the ball when they signal the ball is out of bounds. They also signal for offside and other infractions that the referee may not have seen.

The game begins with the toss of a coin to determine which team will kick off. The other team chooses the goal to defend. Players then take their positions. The ball is placed in the center of the field. The game begins when the ball is kicked off. On kickoffs the ball must travel forward the distance of at least the circumference of the ball.

The time clock starts with the first-half kickoff and runs continually for the established time period. A score is made when the ball passes through the opposing team's goal. After a goal, the team scored upon kicks off and play continues.

THE PLAYING FIELD

The playing field is a rectangle varying from 50 to 100 yards in width and from 100 to 140 yards in length. A smaller-size field may be used if the league agrees. Usually the playing field is twice as long as it is wide.

Goal lines mark the ends of the field. Touchlines mark the sides of the field. The length of the field is divided by a centerline. This centerline is used on kickoffs from a spot on the centerline called the center spot. A center circle is drawn around the center spot. Defenders must be 10 yards from the ball during kickoffs.

The goal is placed at the middle of each goal line. Goals consist of a net, posts, and a crossbar. Regulation goals are 8 yards wide and 8 feet high. Your league establishes the goal size.

In front of the goal is a small rectangle called the goal area. The goal area is 6 yards by 20 yards. The goalkeeper has certain protections in the goal area. Goal kicks are taken from the goal area.

The larger rectangle around the goal (18 yards by 44 yards) is the penalty area. The penalty spot is 12 yards directly in front of the goal. Penalty kicks are taken from the penalty spot. Corner kicks are made from 1-yard radius quarter-circles at each corner of the field.

PLAYER POSITIONS

There are seven named positions in soccer. Their names and duties are:

- **Forward**—An attacking player responsible for setting up and scoring goals. The forwards are the key offensive players.
- **Striker**—A central forward who scores often.
- **Winger**—The right and left outside forwards.
- **Midfielder**—Both an offensive and defensive player responsible for “linking” the forwards and defenders.
- **Defender**—Defensive player whose duty is to help the goalkeeper protect the goal. This player usually, but not always, stays at the rear of the attacking (offensive) team.
- **Sweeper**—A defender who covers behind the fullback line. This player’s duty is to pick off stray passes.
- **Goalkeeper**—The last defender of the goal. The goalkeeper is the only player who can use the hands. Use of hands is limited to the penalty area.

PROGRAM FIELDS OF EMPHASIS

The following ideas will help you plan a well rounded program. Program managers carry out these ideas with help from a team committee member.

ADVANCEMENT

- Review each Varsity Scout’s advancement status
- Conduct a merit badge clinic for Backpacking or Hiking to assist team members with leg muscle development.
- Monitor the team advancement chart regularly.

HIGH ADVENTURE/SPORTS

- Program manager outlines or updates the team’s annual special high-adventure event (Philmont, Florida Sea Base, etc.).
- Conduct a Varsity soccer activity.

PERSONAL DEVELOPMENT

- Work with a men’s clothing store owner or buyer to present a program on good dress and grooming
- Ask a member of the team to share what earning his religious emblem meant to him. Encourage others to earn the religious emblem of their faiths.

SERVICE

- Build wind chimes for members of a retirement center or health care facility. Plans for the chimes can be found at hobby stores or in your public library.
- Assist with the Meals on Wheels program. Offer service as a team or as individuals.

SPECIAL PROGRAMS AND EVENTS

- Go skating with another Varsity Scout team. After learning the basics, try a game of hockey.
- Set up a first-aid disaster drill. Conduct instruction sessions for the more complex injuries and wounds. When the team is ready, carry out the exercise. Ask for assistance from Civil Defense, American Red Cross, and military organizations that are in your community.
- Have a coed skating party.

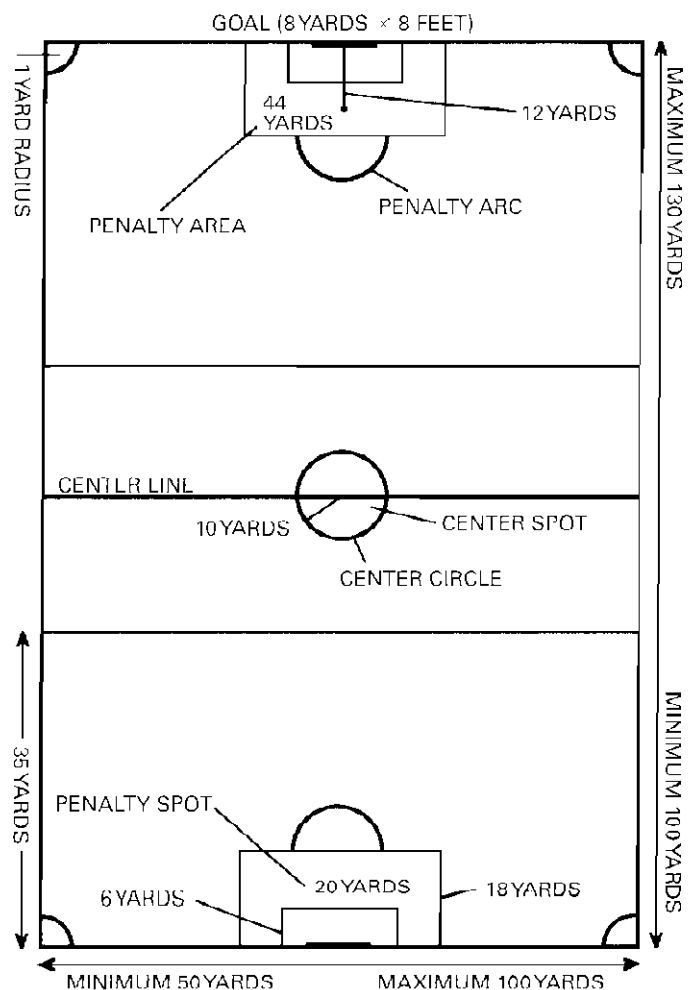

CONDENSED RULES OF SOCCER

The field—See diagram.

The ball—27 to 28 inches in circumference, 14 to 16 ounces in weight.

Number of players—Equal number of players, usually 11, but may be fewer. One must be goalkeeper.

Play equipment—Consists of shirt, shorts, socks, and shoes. Goalkeeper must wear colors distinguishing him from the other players.

Referees—One referee is in control of each game. The referee's decisions are final.

Linesman—Two linesmen assist the referee. They indicate offside, ball out of play, and which team is entitled to the corner kick or throw-in.

Duration of the game—A regulation game consists of two equal periods of 45 minutes. The league determines the length of play.

The start of play—A flip of a coin determines which team will kick off. Each team must stay on its own half of the field and the defending players must be at least 10 yards from the ball until it is kicked. After a goal, the team scored on will kick off. At halftime, the teams change ends of the field. The kickoff will be taken by the opposite team to that which started the game. A goal cannot be scored directly from a kickoff.

Ball in and out of play—The ball is out of play when it has wholly crossed the goal line or touchline, whether on the ground or in the air, or when the game has been stopped by the referee.

Method of scoring—A goal is scored when the whole ball has passed over the goal line, between the goal posts and under the crossbar.

Offside—A player is in an offside position if the player is nearer to the opponent's goal line than the ball *unless* (a) the player is in his own half of the field of play or (b) there are at least two opponents, including the goalkeeper, closer to their own goal line than the player is.

If a player is declared offside, the referee shall award an indirect free kick, which shall be taken by a player of the opposing team from the place where the infringement occurred, unless the offense is committed by a player in the opponent's goal area. If committed in the goal area, the free kick shall be taken from a point anywhere within that half of the goal area in which the offense occurred.

Fouls and misconduct—A player who intentionally attempts to or actually kicks, trips, jumps, charges violently, charges from behind, strikes, holds, or pushes an opponent, or intentionally handles the ball shall be penalized by a direct free kick. Any of these offenses committed in the penalty area by a defender will result in a penalty kick awarded to the offensive team.

A player committing less flagrant violations such as offside, dangerous play, obstruction, or unsportsmanlike conduct will be penalized by an indirect free kick.

Free kicks—Free kicks are classified into two categories:

- Direct, from which a goal can be scored directly against the offending side.
- Indirect, from which a goal cannot be scored unless the ball has been touched by a player other than the kicker before entering the goal.

For all free kicks, the offending team must be at least 10 yards from the ball until it is kicked.

Penalty kick—A direct free kick taken at the penalty mark. All players except the goalkeeper and the player taking the kick must stay outside the penalty area or at least 10 yards from the ball (hence the arc at the edge of the penalty area)

Throw-in—When the ball has wholly crossed the touchline, it is put back into play by a throw-in from the spot where it went out and by a player from the opposite team that last touched it. A goal cannot be scored directly from a throw-in.

Goal kick—When the ball has wholly crossed the goal line after being last touched by a player from the attacking team it is put back into play by a kick from the goal area by the defending team.

Corner kick—When the ball has wholly crossed the goal line after being last touched by a player from the defending team, it is put back into play with a kick by the attacking team from the corner on the side the ball went out.

SOCCER PRACTICE

Practice sessions are held during the season that the Varsity team is playing soccer. Practice sessions can be a part of the regular team meeting or a separate meeting. These sessions develop not only the physical side but also the mental side of the Varsity Scout.

There will be many opportunities to blend the sport of soccer with the game of life. Smart coaches and team captains use these opportunities to strengthen the individual Scout as well as the Varsity team.

Practice sessions have four parts:

1. Warm-up and conditioning exercises. Simple warm-up exercises, both with and without the ball, allow for loosening the muscles and help in avoiding injuries. Vary the pace and type of exercise. Questions should be asked to stimulate thinking about proper eating habits and the importance of exercise throughout life. This portion of the meeting should take about 10 minutes.

2. Skills development drills. Teaching of fundamentals is essential at every level of soccer. Take time to teach basic skills at every practice session and plan simple drills to reinforce the points.

Players should work in groups of two to four so that no one gets bored or slighted. Use as many balls as possible. Drills should be brief to keep things moving and to save time for scrimmage.

3. Team talk. Make this a regular, normal part of practice. Use it as an opportunity for education and personal development. Team members should be encouraged to talk about such things as rules of the game, principles of team play, positions on the field, team tactics, and concepts of fair play.

These rules, principles, positions, tactics, and concepts apply to everyday life as well as to the sport of soccer.

4. Practice (scrimmage) games. Several games should be going on at the same time. Team members in groups of three-on-three or four-on-four rotate into all positions so that each player learns to play everywhere on the field.

WARM-UP AND CONDITIONING EXERCISES

Healthy young players are always ready to play the game and rarely look forward to any preliminary "exercises." It is important to avoid making the warm-up drudgery. Interpret its importance in helping get players ready for strenuous exercise.

The warm-up exercises used and the attitude about them will strongly influence the Scouts' lifetime attitudes about exercise.

Have Scouts use a soccer ball as much as possible for exercises. Select new exercises for each practice and also repeat some that have been done before.

To begin, players position themselves in a circle, in double lines, or in a semicircle facing the leader. Let players take turns choosing and leading exercises. When a player leads, coaches can work closely with individual players or exercise with the players.

Remember: Demonstrate the exercise or game first. Tell why the exercise is important. Have players do the exercise slowly together. Then exercise at regular speed.

STRETCHING EXERCISES

Deep breathing. Ask players to take several deep breaths, expanding the chest fully by inhaling, then relaxing while exhaling.

Slow arm circles. Walk in a circle. Swing arms forward and then backward.

Side benders. Hands on hips, bend to one side, then the other.

Trunk twisters. Hands on hips, twist to one side, now the other.

Toe touching. Touch opposite toe, with knees slightly bent.

Front thigh stretch. Lift leg with knee bent. Grasp shinbone and pull knee close to chest.

Back thigh stretch. Bend knee and bring heel up toward back side. Grasp ankle and pull toward back side. Neck rotation. Gently rotate head from side to side.

Ankle rotation. Rotate the foot without moving the knee, then with knee rotating.

Thigh and leg stretch. Take position of sprinter on toes. Lower the hips to the ground without moving feet. Repeat each side.

Forward crawl stroke. Stretch arms forward in crawling motion.

WARM-UP EXERCISES WITH THE BALL

- Standing with feet apart, roll the ball on the ground in a figure-eight pattern around the feet with hands and fingers.
- Players lie on their backs and roll the ball over the stomach. Next, raise the body and roll the ball under the back. Repeat several times.

- Each player dribbles two balls at the same time for a distance of 20 yards. Practice keeping the ball close to the feet.
- Each player balances a ball in the hollow of the shoulder at the back of the neck. With arms out for control and balance, walk and then run without losing control of the ball.
- From a standing position, feet together, players hop over the ball, side to side then front to rear, knees high, keeping the feet together.

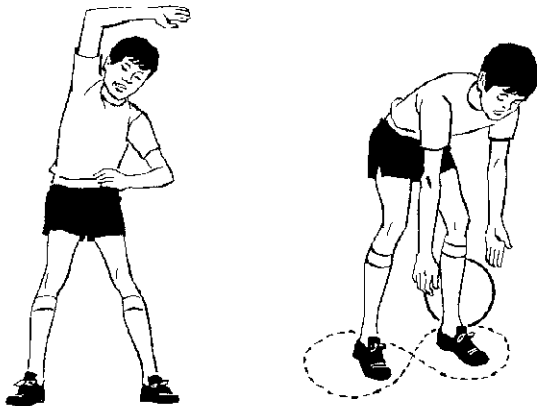

- Players pass the ball to a partner as quickly as possible without stopping it, alternating feet with each pass. Make 10 passes and change partners.
- From a standing position, players straddle the ball and tap it back and forth between the legs. Repeat 10 times.
- In pairs, players lie on back feet-to-feet and do sit-ups in unison, passing the ball back and forth with each sit-up.
- Players stand with feet wide apart, holding a ball overhead with both hands. Players touch the ground next to the right foot, bring the ball back overhead, then touch the ground next to the left foot. Repeat six times.
- Each player stands with the ball and tosses it high in the air. Before catching the ball, sit on the ground and stand again.

SKILLS DEVELOPMENT DRILLS

Skill development, while important, must not take so much time it seems to become more important than the game. Each of the skills must be checked to be sure it is within the ability of the players. Never get so advanced that the drills are beyond the capability of the players.

JUGGLING

Juggling is using the head, thighs, chest, and feet to control the ball without letting it touch the ground. It's the first skill to learn in soccer because it develops balance, coordination, and confidence.

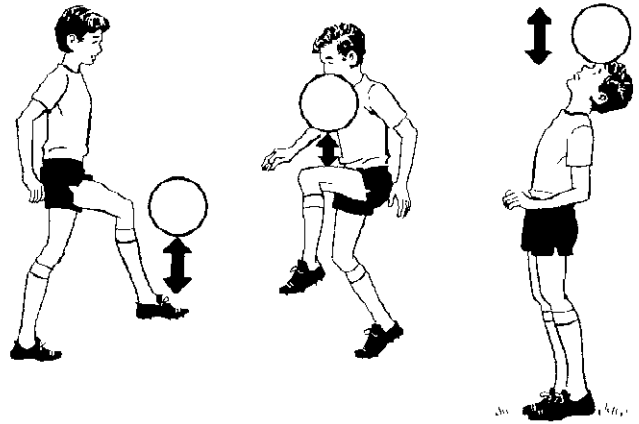

THE BASICS OF JUGGLING

- To begin, drop the ball to the ground and trap it with your foot.
- Use the instep of the foot (the flat, top part of your foot where your shoe is laced), the fleshy part of your thigh, and your head, tilting your head back to use the flat surface of your forehead.
- Practice using both sides of the body—left and right.
- Start slowly and gradually increase the number of repetitions. Keep your eyes on the ball!

TEAM DRILLS

Learning to juggle. Players form a circle, each player with a ball. The coach, from the center of the circle, leads the drill. Balance the ball on one instep for 10 seconds, then on the other instep. Drop the ball to the instep, with the foot 10 inches off the ground, then catch the ball with the hands. Repeat the exercise with the opposite foot.

Instep juggling. Players form a semicircle, each player with a ball. The coach demonstrates instep juggling and the players repeat. Drop the ball to one foot and keep the ball in the air, alternating feet. Have players count repetitions and try to increase the number of repetitions each time.

Thigh juggling. Players take a partner, with one ball for each pair. One player tosses the ball in the air and juggles with the left thigh, juggles with the right thigh, and catches the ball. Partners take turns counting repetitions for each other.

Head juggling. Players form a circle, with the coach in the center. The coach demonstrates juggling by heading the ball. Players follow. Standing, toss the ball in the air, head the ball and catch it with the hands. Then head the ball twice and catch it, three times and catch it up to as many juggles as players are able to complete.

DRIBBLING

Dribbling is the skill of controlling the ball with your feet while moving around an opponent in any direction you want to go.

Good dribbling requires speed, the ability to change directions quickly, and the use of feints to move the ball down the field while you look for openings for a pass or dodge past opponents.

THE BASICS OF DRIBBLING

- Control the ball by pushing it in front of you, within 2 or 3 feet of your feet.
- Use the front part of your foot, touching the ball near the inside or outside of the foot, near your toes.
- Learn to control the ball by touch, without looking at it, so you can look at the defense and your teammates to decide whether to continue dribbling, pass the ball, or shoot.
- Shield the ball by keeping your body between your opponent and the ball.

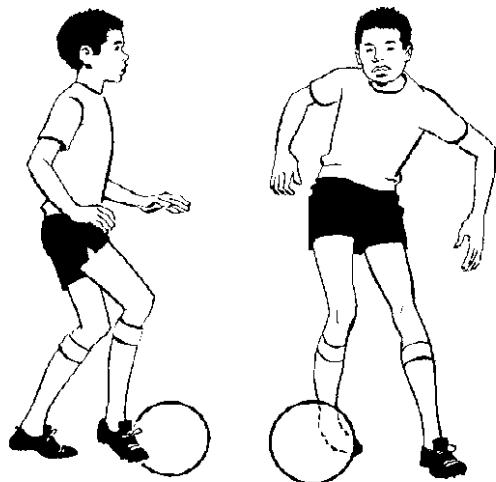

DRIBBLING FEINTS

A sudden unpredictable move, or feint, misleads your opponent into making a wrong move and enables you to complete your intended move.

Foot feint. Stop suddenly while dribbling by placing your foot on the top of the ball. Quickly move in a new direction before your opponent reacts.

Step over the ball as if you were moving in that direction. If your opponent reacts, push the ball in the opposite direction and run by your opponent.

Body feint. Take one step and lean your head and shoulders as if you were moving in that direction. If your opponent moves, quickly push the ball in the opposite direction and around your opponent.

Take a pass in one direction, then move the ball quickly in the opposite direction and around your opponent.

TEAM DRILLS

Dribble race. Divide players into two teams that stand at opposite touchlines, each player with a ball. Teams dribble to the opposite line and back. The first team with all players to finish wins.

Whistle dribble. Players line up on the touchline. At the whistle, they start dribbling across the field. At the next whistle, they stop and control the ball. At two consecutive whistles, they reverse directions.

Dribbling feints. Pair off the players. The player with the ball dribbles in a 10 square yard area, with the second player acting as an opponent. The player with the ball tries foot feints and body feints for one minute. Players trade positions and repeat.

Control dribble. Place eight to 10 markers 4 feet apart. Each player with a ball dribbles around the markers in a figure-eight pattern. Have the players use the right foot only, then the left foot only, then both feet.

TRAPPING

Trapping is the skill of getting the ball to your feet as quickly as possible so that you are ready to dribble it forward, make a pass, or take a shot at the goal.

However you receive the ball from a teammate, you must be able to control it as quickly as possible without using your hands and arms.

THE BASICS OF TRAPPING

- Keep on your toes and be ready to position your body so that you can control the ball quickly, with confidence.
- Trap the ball with the inside or outside of the foot, instep, thigh, chest, or head.
- Meet the ball. After contact, relax and give way slightly to reduce the impact and cushion the ball.
- Keep your eyes on the ball and control it. Be ready to play the ball quickly.

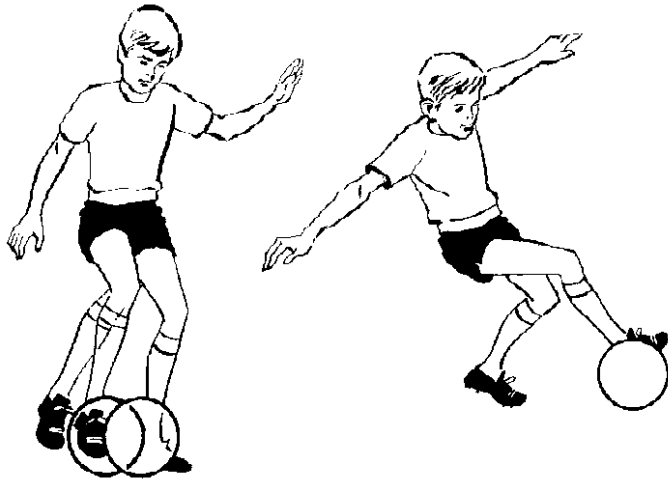

TECHNIQUES

Inside-of-the-foot trap. Meet the ball with the inside of your foot at the moment the ball hits the ground. Relax the foot and lower part of the leg to smooth the upward bounce of the ball.

Outside-of-the-foot trap. Meet the ball as it hits the ground, relax your ankle, and cushion the ball with your foot and lower leg to smother the bounce.

Thigh trap. Raise your leg with the knee bent, and contact the ball with the soft inside part of your thigh. At impact, lower the thigh slightly and relax the muscles, dropping the ball to the ground.

Chest trap. Lean back to form a “platform” with your chest. As the ball hits your chest, relax and withdraw slightly to cushion the ball and drop it to your feet.

TEAM DRILLS

Partner trap. Players stand 10 yards from a partner. The player with the ball tosses it in the air to the partner, who traps the ball first with the inside of the foot, then the outside of the foot, the thigh, and the chest. Alternate tossing the ball and trapping.

Running trap. Each player tosses the ball in the air while moving across the field. Practice trapping the ball using all types of traps.

Opponent trap. Divide the players into groups of three. The objective is to move across the field with two players passing and trapping the ball while a third player attempts to take possession. The first player tosses the ball to a second player, who has the third player as an opponent. The second player traps the ball and passes it back to the first player. Players should be moving across the field during the drill. Rotate positions.

PASSING

Passing is the skill of kicking or heading the ball to a teammate and is essential to successful team play.

Soccer passes are made with the inside or outside of the foot, the instep, or with the forehead (called “heading”).

THE BASICS OF PASSING

- Face your body and point your foot in the direction of the pass. Keep your eyes on the ball as you kick it.
- Approach the ball with your regular running stride and concentrate on a rhythmic swing of the leg from the knee, not from the hip.
- Firmly place your nonkicking foot next to the ball to give you balance and help aim the ball.
- Pass to your teammate's feet at a speed that helps him or her receive the ball easily.

TECHNIQUES

Inside-of-the-foot pass. (For short passes when accuracy is needed.) Place your nonkicking foot next to the ball and strike the ball with the inside of your kicking foot. Follow through with your kick, keeping your eyes on the ball throughout the kick. Keep your ankle rigid.

Instep pass. (A power kick for cross-field passing.) Point your kicking foot straight down and contact the ball with the flat top part of your foot, at your shoelaces.

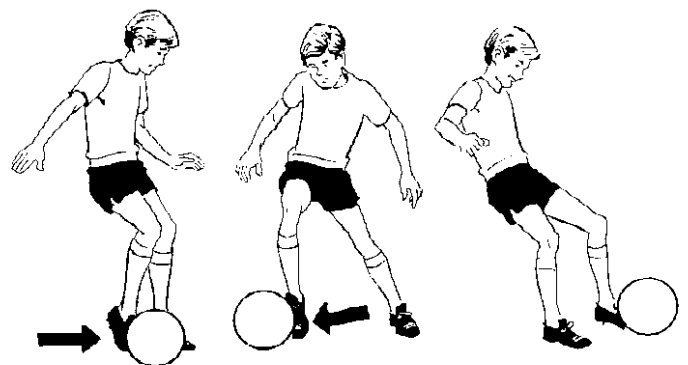
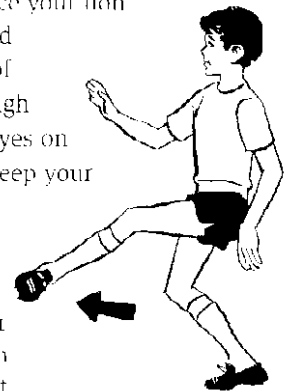

Outside-of-the-foot pass. (For quick and deceptive passing.) Turn the toes of your kicking foot inward and kick the center of the ball at the outside of your shoelaces.

Lofted pass. (A long-distance pass) Approach the ball from a slight angle (from the left if you are kicking with your right foot). Place your nonkicking foot to the side and slightly behind the ball. With a full backswing, strike the ball slightly underneath (below the center line) and follow through with the toes pointing in the direction of the pass.

SHOOTING

Shooting the soccer ball utilizes the techniques of kicking, passing, and heading to score by shooting at the goal.

When you shoot, aim away from the goalkeeper and into the corner of the goal with a lot of power behind the shot so that the goalkeeper can't get to the ball and block your score.

THE BASICS OF SHOOTING

- Learn to shoot quickly, without giving your opponents a chance to get into position to block your shot.
- Use an instep kick whenever possible, because it is probably the most accurate and powerful for shooting.
- As your foot contacts the ball, keep your head down and your eyes on the ball.
- Practice shooting with both left and right feet, and by heading the ball.

TEAM DRILLS

Two line relay. Divide players into two groups that line up in two single lines about 15 yards apart. The first player in line passes the ball to the front player in the opposite line, and runs to the back of that line. The receiving player traps the ball and passes it immediately to the next player in the opposite line and runs to the back of that line.

Two-on-two. Divide players into groups of four. Have each group play two-on-two in a designated area (the size of the penalty area) for three minutes. No shooting.

Passing pairs. Players in pairs line up on the touchline about 5 yards apart. As a team, players dribble and pass the ball to each other as they cross the field. Concentrate on accuracy and control, not on speed.

Circle kick. Players line up in a semicircle 10 to 15 yards from the goal. The goalkeeper calls out the name of a player, who takes a shot at the goal with an instep kick. The player retrieves the ball and returns it to the goalkeeper. Use two goals to give players maximum shots at the goal. It's a good idea to use two or three balls.

Line kick. Players form a single line with the lead player in line 10 to 15 yards from the goal. The coach begins

the drill by rolling the ball to the player at the front of the line, who shoots for the goal, retrieves the ball, and goes to the end of the line. Repeat the sequence until all players have made 3 to 10 shots at the goal.

HEADING

Heading means controlling the ball with the center of the forehead and is an important skill for all players to learn.

Heading doesn't hurt if it is done right. You might want to learn heading with a volleyball or other softer ball at first.

Power and distance are achieved by getting the weight of your body behind the ball and by good timing.

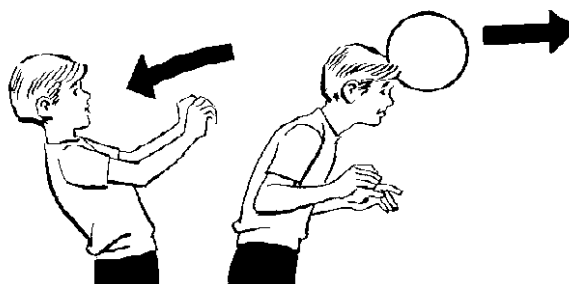

THE BASICS OF HEADING

- Watch the ball as it comes toward you. Keep your eyes open and your mouth closed.
- Attack the ball. Don't let it play you.
- Arch your body backward at the waist as you prepare to meet the ball. Swing the whole top half of your body forward (not just your head), using your neck muscles to thrust your forehead at the ball.
- Proper timing in hitting the ball is essential to heading.

Both feet will usually be off the ground when the ball is headed. Time the jump to head the ball at the highest point of your jump. Kick your legs behind you to help arch your back and follow through with your forehead, directing the ball downward in the direction you want it to go.

TEAM DRILLS

Beginning header. Players form a circle, each with a ball, with the coach in the center demonstrating heading. Hold the ball about 6 inches in front of your face and bounce it off your forehead, catching the ball. Gradually increase the distance, keeping your eyes open and your head stiff.

Next, use your head to keep the ball in the air, keeping your head bent well back, and staying on your toes.

Heading partners. Divide the players in pairs, with one ball for each pair. Each player heads the ball out of his own hands to the partner. Repeat 10 times.

Circle leader. Divide the team in half and have each group of players form a circle around one leader. The leader heads the ball to each player in the circle. When the leader is finished, a new player takes over until every player has been the leader.

TACKLING

Tackling means using your feet to charge your opponent and take the ball from him. Tackling is similar to a slide in baseball. This is an essential defensive skill in soccer.

The most important thing to remember about tackling is that you must attack the ball—not the player.

THE BASICS OF TACKLING

- Concentrate on the ball and not on your opponent's body movements.
- Crouch forward slightly, plant your tackling foot firmly on the ground next to the ball, and try to push the middle of the ball with your foot.
- Shoulder-to-shoulder contact is allowed to nudge your opponent away from the ball. But don't kick or trip your opponent, or hit the opponent's back or chest with your shoulder.
- Get behind the ball and block it rather than trying to kick it away. Don't lunge at the ball.

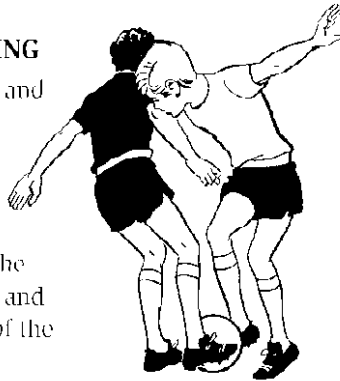

TEAM DRILLS

Three-on-three. Divide teams into groups of six. Play three-on-three with no shooting in the penalty area. Three consecutive passes are worth one goal. Play three minutes and change teams. Players concentrate on tackling the ball.

Dribble tackle. In pairs, players take turns dribbling past a partner, who tries to tackle the ball. Players begin the drill 10 to 15 yards apart, and at the whistle move toward each other. Change roles and repeat the drill.

VOLLEY KICK

Often you will need to kick the ball as it comes to you in the air without taking time to trap the ball and get it into position on the ground.

This is called a volley kick—when the ball is kicked before it hits the ground.

The techniques are exactly the same as when kicking a stationary ball, except that both you and the ball are moving and your timing must be very accurate.

THE BASICS OF VOLLEYING

- Keep your eyes on the ball throughout the kick. Let the ball drop as low as possible before kicking it.
- Meet the ball at your shoelaces for a forward power kick or with the inside middle of the foot if you want to make a short pass.
- Try to aim your kick. Lean forward and into the ball.
- Follow through on your kick, keeping your head down, your eyes on the ball, and your body in balance.

TYPES OF VOLLEYS

Inside-foot volley. Raise your kicking leg with the foot turned outward and your thigh horizontal or pointing upward. Kick the middle of the ball with a short, solid swing of the foot as in inside-foot passing.

Instep volley. Keep your toes pointed down and meet the ball with a sharp swing of the knee. Hit the ball with your full instep (at your shoelaces) as in instep passing.

Half-volley. When you can't reach the ball before it hits the ground, you may be able to kick it right after it bounces. This is called a half-volley. Try to kick the ball when it is no more than an inch off the ground.

TEAM DRILLS

Volley-serve. Divide the players into groups of four. A server in each group tosses the ball to each of the other three players, who instep volley the ball back to the server. Players rotate to server position after five volleys.

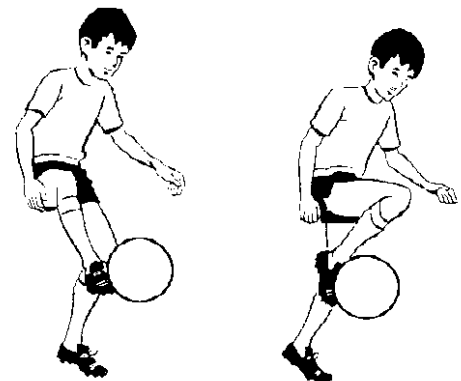

Half-volley. Each player walks with the ball, drops the ball to the ground, and half volleys the ball as many times as necessary from goal line to goal line. Use the inside-foot volley or instep volley. Players retrieve their own balls. The emphasis of this drill is to develop control rather than distance. Repeat the drill with players running when they drop the ball.

Half volley pairs. Divide the team into two groups of equal number. Players take turns using the half volley to kick ball to each other. Alternate instep and inside-of-foot volley.

THROW-IN

The throw-in is awarded a team when the opposing team last plays or touches the ball before the entire ball passes beyond the touchline.

The throw-in is very important in soccer. It is the only time you may use your hands (unless you're the goalkeeper), and although you cannot score by throwing the ball into the goal, you can use a good throw in to set up a scoring play.

You may take a one- or two-step run up before you throw the ball, but most of the power comes from strong arm and wrist action with a firm swing of the body from your waist.

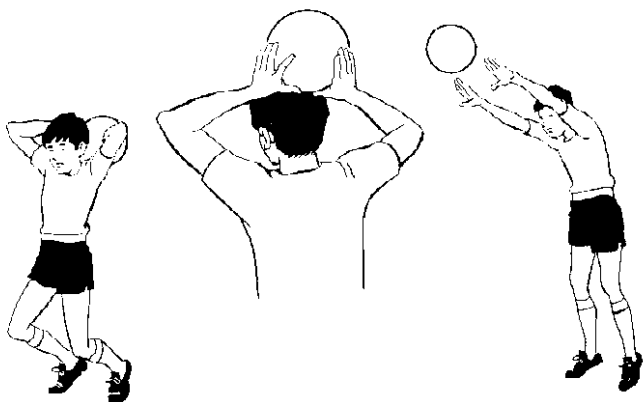

THE BASICS OF THE THROW-IN

- Face the field of play with both feet on or behind the touchline. Look for a teammate in good position to receive the ball.
- Grip the ball with both hands from behind your head. Spread your fingers on the ball for firm control.
- Keep both feet on the ground as you complete the throw in. Your feet should be placed about shoulder width apart.
- From behind your head, throw the ball forward in one continuous motion with both hands, arching your back and bending your knees slightly.

TEAM DRILLS

Partner throw in. Players sit on the ground with a partner, facing each other 5 to 10 feet apart. One player has the ball in position behind the head, rolls on the back as if doing a sit-up, sits up, and throws the ball to the partner. The partners alternate throwing and catching. This drill is also recommended for warm-up.

Circle dodgeball. Players form a circle with one player in the center of the circle. Using the throw-in technique, players attempt to hit (tag) the center player with the ball. When hit, the center player replaces the player who threw the ball.

Alternative: Divide the players into groups of three, one player taking a position between the other two players as the leader. Use one ball for each group of three players.

Throw-in trap. Players in pairs stand 10 to 20 feet away from each other. The player receiving the throw-in traps the ball before throwing it back. Alternate foot, thigh, and chest trap.

GOALKEEPING

The goalkeeper's duty is to keep the other team from scoring by preventing the ball from entering the goal.

As the only player allowed to use the hands, the goalkeeper may catch the ball, block it away, or deflect the ball off course.

Goalkeeping is the most specialized position on a soccer team because it requires a set of skills unlike those used by the other players. All players should learn the skills of goalkeeping and play this position as well as all others. Young players should not specialize in any one position.

THE BASICS OF GOALKEEPING

- Always try to get your body behind the ball when you catch it, gripping it firmly to your chest.
- Be aggressive and be ready if necessary to reduce the opponent's shooting angle at the goal before the shot is made by moving away from the goal toward the opponent as he or she approaches the goal.
- When you advance away from the goal, be alert to the ball being lobbed or chipped over your head.
- When you gain possession of the ball, immediately protect the ball with your arms and body. Quickly assume an attacking position to get the ball into play. Throwing or rolling the ball to a teammate is safer than kicking it.

TECHNIQUES

Basic position. The basic position is at the center of the goal, about 1 yard in front of the goal line. Place your feet about shoulder width apart, bend your knees slightly, and keep both hands up, ready to reach for the ball.

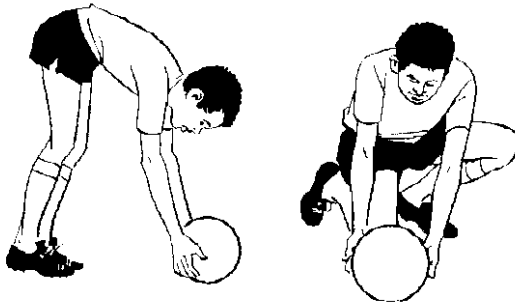

Stopping ground balls. Place one knee on the ground so that your legs back up your hands if you fumble the ball. Grasp the ball to your stomach or chest and immediately get to your feet to avoid a collision and put the ball back into play.

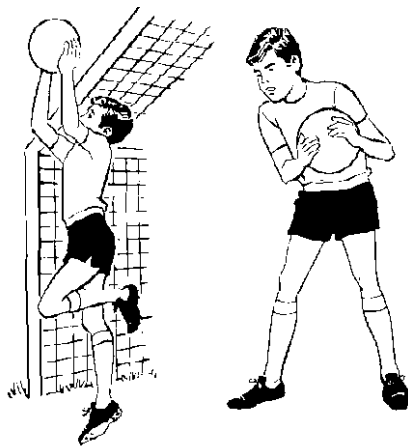

Stopping high balls. Meet the ball -- don't wait for it to come to you. Always try to face the ball, catch it, and bring it down to your stomach or chest in one movement.

With a ball chest-high, lean slightly forward so that the force of the shot cannot push you backward. If the ball is slightly below your waist, bend your knees slightly and form a "cradle" with your hands in front of your stomach to catch and protect the ball.

If you have to jump to catch the ball, time your jump so you catch the ball at the height of your jump in front of your head, watching the ball as it reaches your hands.

Deflecting the ball. Often the ball is kicked too high or fast for the goalkeeper to actually catch the ball. When this happens, try to deflect the ball away from the goal with one or two hands. Hit the ball as solidly as possible and deflect it as far away as you can, either back in the direction from which it came, or across and over the top of the goal.

Diving for the ball. Push with your legs toward the ball. Keep your hands and elbows close together as you catch the ball. The forearm and ball should contact the ground first to absorb the thrust of the dive, then your shoulder and hips. As your shoulder and hips touch the ground, kick your feet in the air to further absorb the impact of the dive. Cradle the ball with your arms and legs, getting your body down as quickly as possible.

Advancing the ball. After gaining possession of the ball, it is the goalkeeper's duty to initiate the offense through distribution of the ball to a teammate. It is to the team's advantage for the goalkeeper to get rid of the ball quickly by rolling, throwing, or punting to a teammate. Rolling is done as if you were bowling, following through with good force. Throwing is done with a side-arm baseball pass, aiming carefully at an open teammate. Punting is for distance (if no teammate is open); it is done with an instep-volley kick.

TEAM DRILLS

Team goalie. Players form a semicircle 10 to 15 yards in front of the goal. Use two balls. Players take turns shooting, and the goalkeeper tries to block the shots. While the ball is being retrieved, the second ball is used so the goalkeeper has to keep moving.

Rotate goalkeepers every 10 shots so each player can experience the goalkeeping position.

Practice diving. Divide players into pairs, about 10 feet apart. The goalkeeper sits on the ground. Partner throws the ball to the left and right of the goalkeeper, forcing player to move quickly and dive for the ball. Move to kneeling and then standing position. Swap positions after three minutes.

Distribution. Divide players into pairs, 15 feet apart. The goalkeeper practices throwing, rolling, and punting the ball to the partner. Each partner traps and shoots the ball back to the goalkeeper. Increase distance gradually.

REVIEW THE RULES

This chapter contains simplified rules for soccer. The league will have a set of more detailed rules available for the team.

Review these rules with the team well ahead of the first season game. Players should be encouraged to become knowledgeable about the game so they are able to enjoy watching as well as playing.

The offside rule, perhaps the most confusing rule in soccer, should be demonstrated and explained until all players (and the coaches) understand it. Don't assume players know the rules.

As you go over each rule, explain its purpose and how it affects the game. Don't forget to describe the official's signals. Key moments of the game should also be thoroughly explained so that players are as familiar with them as with the free kick, throw-in, goal kick, corner kick, penalty kick, and drop ball.

DISCUSS THE POSITIONS ON THE FIELD

Positions vary, depending on the system of play employed by the team. The coach should work to develop a system that best suits the abilities of the players.

It is useful to select a system to offer a framework for understanding the responsibilities of each position. All players should understand that they are free to play outside the areas to which they are assigned and that all players play both offense and defense.

HELP PLAYERS UNDERSTAND THE BASIC PRINCIPLES OF PLAY

Space. A team should use the entire field to spread out the opponent's defense and to open up areas into which offensive players can move. Players should create space between themselves and the teammate with the ball.

Time. Time is a crucial element in moving the ball. Highly skilled players can trap, know where teammates are on the field, and pass the ball to a teammate quickly.

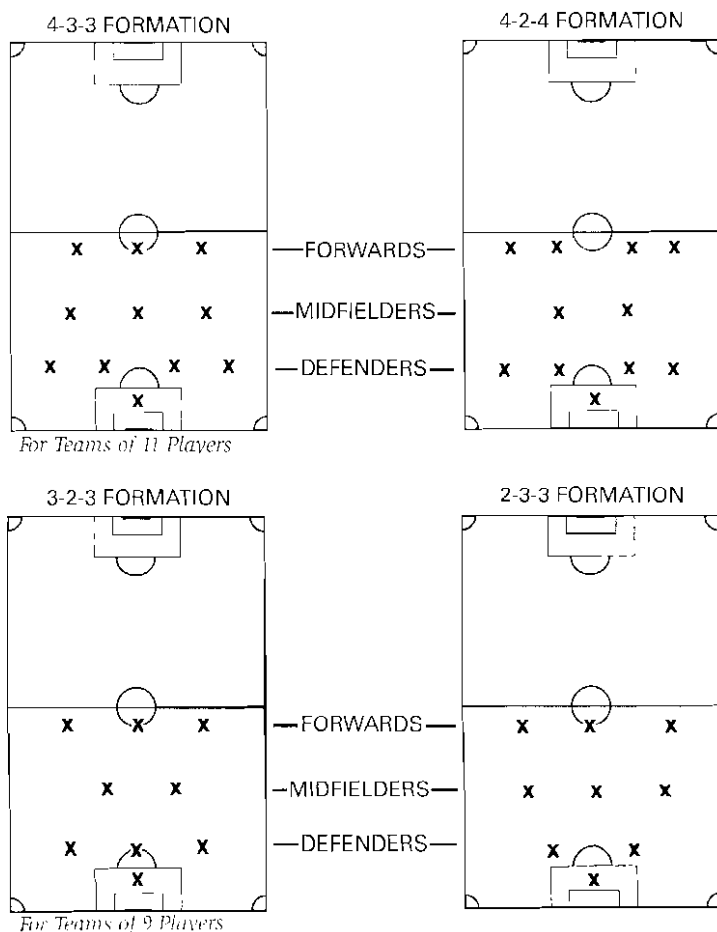

Movement. Players should be moving constantly, regardless of whether they have the ball. Encourage players to pass and immediately run to an open position. This supports teammates.

TEAM ATTACK

Keeping in mind the basic principles of space, time, and movement, the following additional concepts should be explained for the attacking team.

- Penetrate the defense. Pass, dribble, and run to open space. Be ready to receive a pass and to divert the defending players away from the ball.
- Create a combination play. Players should move quickly and interchange positions to look for passing opportunities and make it harder for the opponent to defend.
- Go for the goal. The purpose of attacking is to score. The object is to finish all attacks with a shot at the goal.

TEAM DEFENSE

Teams can use a one-to-one, zone, or combination defense. It is recommended that younger players learn the principles of one-to-one defense before attempting the zone defense.

PRINCIPLES OF DEFENSIVE PLAY

Think defense. When your team loses possession of the ball, the player closest to the ball should immediately try to tackle the ball.

Delay the attack. Players run to defensive positions to prevent passes and to create time for the defense to get organized.

Pressure the player with the ball. Force the attacking player to make errors by trying to tackle the ball.

Defend the goal. Always protect the goal immediately. As the attacking team approaches the goal, defenders should concentrate in the goal area.

SCRIMMAGE AND PRACTICE GAMES

Even though warm-ups and skill training are fun for players, they most enjoy playing the game.

The following games suggest an approach to developing the team.

- The games should be progressive in nature, from a simple game to a regular practice scrimmage with two full teams.

- Tie the games into the skills development drills by selecting games that reinforce learning.
- Restrict the games to a small, well-defined area on the field and limit the number of players in each game.
- Always create a way for teams to score, using such methods as make shift goals, timed possession of the ball, or a predetermined number of passes.

GAME 1: TWO-ON-ONE

Mark an area 10 yards square (use balls or other markers at the corners). Two players take possession of the ball and keep it away from one defender for three minutes. Rotate players after each three-minute game.

GAME 2: THREE-ON-THREE

Players are divided into teams of three. The objective is to score a goal past the three defenders positioned on the goal line.

The attacking team begins with players on the left and right of the center player with the ball. Each player follows his or her own pass, moving into the position previously occupied by the player receiving the pass, creating a weave as the ball is interchanged.

Alternately, one defender guards the goal while the additional two players take positions behind the goal to receive the ball. After each attack, defenders become attackers.

GAME 3: THREE-ON-TWO

Use the same teams and objective as in game 2, except bring one of the defending players off the goal line to assist in the defense.

For this game, a goal is needed at each end of a 20-yard area.

At the start, the defender should return the ball to an attacker when he or she cuts off a pass. Later, the defenders can start their own attack when they gain possession.

The passer follows the ball and moves ahead of the player receiving the pass (behind the defender). Through passes are then returned to either attacking player.

Start slowly and speed up the attack as players increase their skill.

GAME 4: THREE-ON-THREE

Select teams of three players who compete in an area 20 yards square (using two goals).

The opposing team must position one player as a goalkeeper. When possession of the ball changes, the goalkeeper joins the attacking team and one player on the opposing team falls back to become the goalkeeper.

Teams play for a designated time period. The team with the most goals wins.

GAME 5: TEAM CAPTAINS

Select teams of four players and designate an area 20 to 30 yards square as the playing field (no goals are used).

Each team selects a captain. When the captain receives the ball, the team is awarded one point. The ball is given to the opposing team when it is intercepted or goes out of play, or when a point is scored.

Switch captains after three minutes and continue the game. It helps if the captain wears a special hat or shirt.

GAME 6: NEUTRAL PLAYER

Select teams of the three players plus one neutral player. The playing area should be 30 yards square (no goals are used).

GAME 7: TEAM ATTACK

Select teams of five players and use half of the soccer field (two goals).

Players practice becoming targets for passes and creating openings. Encourage players without the ball to occasionally sprint a few steps and change direction suddenly.

Variation: With each pass, players move to a new position, always maintaining the depth and width of the attack.

Play for six minutes, then rotate teams.

GAME 8: TWO-BALL PLAY

Select teams of seven players, using a normal soccer field (goals are not used).

The objective is for a team to maintain possession of two balls for as long as possible with the other team attempting to win possession.

The game begins with one team passing both balls. The game continues until both balls are lost to the opponents, who then assume ball possession.

Award one point each time a team controls both balls for one full minute.

GAME 9: FULL SCRIMMAGE (ONE TEAM)

Select teams of seven players, and use a normal field (with goals).

Play two five-minute halves. Stop the action to explain techniques and team tactics. Encourage players to use skills learned in drills and small team games.

Rotate players to new positions at the end of the first half. Keep score. Repeat two five-minute halves if time permits. Adjust teams if necessary.

GAME 10: FULL SCRIMMAGE (TWO TEAMS)

Play two 10-minute halves on a normal soccer field against another soccer team of the same age or grade level.

Stop the action as necessary in the first half to work with individual players and team tactics. Substitute often to make sure every player gets equal playing time.

In the second half, keep the action moving without interruption.

COACHING LEAGUE GAMES

Coaching soccer games is a great opportunity to get closer to your team. It's also an important time for the coach to model the kind of behavior expected of the players.

BEFORE THE GAME

Start your team in a positive frame of mind.

- Remind them of the basic skills you've been working on in practice.
- Help them remember to think and play as a team.
- Suggest that they not worry about what their opponents might do, but concentrate on what they will do themselves.
- Review the important rules.
- Caution against arguing with officials on close calls.
- Discuss proper conduct on the bench and during warm-ups. Have the team do a few warm-up exercises before the game starts.
- Begin with two or three stretching exercises.
- Divide into groups of two or three and pass the ball.
- Have players form a circle and pass the ball.

DURING THE GAME

- There should be very little coaching from the sideline. Coaching is done at practice, not when the game is under way.
- Substitute as often as league rules allow, giving everybody a chance to play.
- When a player leaves the field for a substitute, talk to the player about how he could improve in specific areas.
- Compliment the player on good performance. Give new ideas and suggestions. This is a helpful job for the assistant coach, too.

Be aware of the influence of your own actions on the behavior of players and spectators.

- Never leave the bench except when absolutely necessary. Coaches are not allowed to enter the field of play except when given permission by the referee.
- Avoid shouting at officials when you feel they make mistakes. (You may want to talk quietly to them at half-time or after the game about specific calls or mistakes.)
- Avoid shouting at players on the field—of either team.
- Correct your players in a quiet, constructive tone of voice off the field.
- Help keep players cool when they lose their temper by first keeping yourself cool.

AT HALFTIME

Quietly review the improvements that players should make in the second half.

- Avoid haranguing or intimidating players.
- Be cool and helpful, and keep your directions simple.
- Avoid sarcastic or negative comments about members of your team, the other team, or officials.

AFTER THE GAME

Encourage your players to congratulate the other team. Have a friendly talk with the other coach or the officials. Bring your team together. Cool down by resting with plenty of water or juice. Have everybody sit down and briefly discuss the game by asking some questions such as these:

- What went well for the team today?
- Which players on both teams really tried hard?
- Was our passing good?
- Did we have a good attitude toward the other team?
- What can we do better next time?
- What do we need to work on in practice?

You will think of many other questions to ask. The important thing is to stimulate the thinking of your players and let them talk to you and to each other.

Try not to lecture or preach. You can support the statements players make that get your own feelings across. Guide the discussion and make it more than just one-way communication from you to the team.

Wrap it all up by complimenting the team on a good effort and reminding them of the next practice or game day, time, and location.

PREVENTION AND CARE OF INJURIES

Soccer is a relatively safe sport for players. But because it is a bodily contact game played with little protective equipment, injuries may occur.

All youth sports are as safe as the environment established by adult leadership for the sport. Soccer coaches should take all necessary precautions to help prevent injury and be prepared to respond when they do occur.

YOUTH SOCCER SAFETY CHECKLIST	
<input type="checkbox"/>	Players' shoes have rubber cleats only (or are regular sneakers).
<input type="checkbox"/>	Players are encouraged to wear shin guards.
<input type="checkbox"/>	Goalkeepers wear proper protective equipment, including elbow, knee, and hip pads, and a sweatshirt and long pants or a sweatsuit.
<input type="checkbox"/>	The playing field is free from all obstacles and hazardous conditions.
<input type="checkbox"/>	There are no hooks or protrusions on the front of goals.
<input type="checkbox"/>	Teams warm up properly prior to practice sessions and games.
<input type="checkbox"/>	Rules and equipment are modified to adjust the physical demands of the sport to the appropriate developmental level of the players.
<input type="checkbox"/>	Teams are properly supervised and coached during practice and games.
<input type="checkbox"/>	Coaches are familiar with immediate steps to take when accidents do occur.
<input type="checkbox"/>	Players are not allowed to play when injured.
<input type="checkbox"/>	Players are taught to treat bruises and sprains with ice packs to reduce swelling and pain.
<input type="checkbox"/>	Practice sessions are reasonable in length and planned to include brief rest periods.
<input type="checkbox"/>	Game rules are enforced by officials and fouls are penalized.
<input type="checkbox"/>	Players are conditioned properly for game play. When injuries do occur, the players and the coach are familiar with the immediate recommended treatment.
<input type="checkbox"/>	First aid is the immediate handling of athletic injuries. If pain persists, refer players to their family physician for follow-up.
<input type="checkbox"/>	Never send an injured player back into a practice or game.

Injury	Suggested First Aid
Muscle pulls, sprains, and bruises	Use ice pack immediately to reduce swelling. Speed of application is essential.
Small cuts	Apply pressure to reduce bleeding. Wash with antiseptic solution and apply sterile dressing if necessary.
Nosebleed	Have player pinch nostrils and hold until bleeding stops. Apply ice pack.
Foreign body in eye	Pull upper lid down, holding eyelash. Wash out with eye-cleaning solution.
Fainting or loss of wind	Rest in cool place. Try to relax player and slow down breathing.
Scrapes and burns	Wash with cleansing solution. If necessary, cover with gauze.
Elbow or knee injuries; jammed finger or toe	Elevate area and apply ice pack. Refer to physician if pain persists.
Shin injury	Apply ice pack and compression. Refer to physician if pain persists.
Back or neck injury	Keep the player calm. Do not attempt to move or sit the player up if pain is severe. If pain is slight, apply ice pack.

GLOSSARY OF SOCCER TERMS

Center. To pass the ball from a wide position on the field into the penalty area.

Charging. Pushing the opponent off balance legally by shoulder-to-shoulder contact.

Clear. A throw or kick by the goalkeeper or a kick by the defender in an attempt to get the ball away from the goal area.

Cross. Same type of pass as center.

Defender. Primarily a defensive player who assists the goalkeeper in protecting the goal.

Dribble. A way of advancing the ball past defenders by a series of short taps with one or both feet.

Forward. Primarily an attacking player whose responsibility is to create and score goals.

4-3-3. The player formation most used today (a goalkeeper, four defenders, three midfielders, three forwards).

4-2-4. Commonly used alternative formation to the 4-3-3 (a goalkeeper, four defenders, two midfielders, and four forwards).

Goalkeeper. The last line of defense. The only player who can use the hands within the field of play. This player is limited to using the hands only within the penalty area.

Half-volley. Kicking the ball just as it is rebounding off the ground.

Hands. Illegal act of intentionally touching the ball with the hands or arms.

Heading. A method of scoring, passing, or controlling the ball by making contact with the head.

Linkman. Another name for midfielder.

Lob. A high, soft kick taken on the volley, lifting the ball over the heads of the opponents.

Marking. Guarding an opponent.

Midfielder. Both an offensive and defensive player who is primarily responsible for linking the forwards and defenders.

Obstructing. Preventing the opponent from going around a player by standing in his path.

Overlap. The attacking play of a defender going down the touchline past a winger on the same team.

Pitch. Another name for the field of play.

Save. The goalkeeper stopping an attempted goal by catching or deflecting the ball away from the goal.

Screen. Retaining possession and protecting the ball by keeping the body between the ball and opponent.

Sliding tackle. Attempting to take the ball away from the opponent by sliding on the ground.

Striker. A central forward position on the team with a major responsibility for scoring goals.

Sweeper. A defender who roams either in front of or behind the defender line to pick up stray passes.

Tackling. Attempting to or taking the ball away from an opponent when both players are playing the ball with their feet.

Trap. Controlling a ball passed close to the player by means of the feet, thighs, head, or chest.

Volley. Kicking the ball while it is in flight.

Wall pass. A pass to a teammate followed by a first-time return pass on the other side of the opponent (give and go).

Wing. An area of the field near the touchline.

Winger. Name given to the right and left outside forwards.

ACKNOWLEDGMENTS

Much of the material in the Varsity soccer chapter is adapted from the *Y Soccer Coaches Manual* and is used with permission of the Young Men's Christian Association of the U.S.A.

SOFTBALL CONTENTS

Background	29
Program Fields of Emphasis	30
Condensed Rules of Softball.	31
Softball Practice	34
Warm-up and Conditioning Exercises.	35
Skills Development Drills	35
Coaching League Games	37
Prevention and Care of Injuries	38
Glossary of Softball Terms	39

SOFTBALL

BACKGROUND



Softball began some 50 years after Abner Doubleday invented the game of baseball as an answer to the question: "How can we continue to play when there's foul weather outside?" George Hancock invented a softball and took the game indoors. The sport caught on, moved back outdoors, and is now played around the world.

Varsity softball should be played for fun. The game is easy to play. With one ball, one bat, and a playing area, many have enjoyed the sport.

This chapter will prepare the team to play in a slow-pitch league. Sections of the chapter include an introduction to and history of the sport, player positions, equipment and playing field, condensed rules, catching and fielding, batting, and base running.

The object of the game is to hit the pitched ball into the fair field of play and run around the three bases and back to home plate, thereby scoring a run, before being tagged out by the opposing team.

At the end of the game, usually seven innings, the team with the most runs is declared the winner. Varsity teams are encouraged to participate in softball leagues found in most communities. These leagues may be operated by church associations, park departments, the YMCA, or sports associations.

The basic rules for all leagues are similar. The number of players, size of playing field, and innings to be played may vary slightly, depending on your location. Varsity softball teams participating in community leagues abide by the rules set up by the league.

You will need some equipment to play softball. Players should provide their own gloves and shoes. A distinctive color shirt and cap identifying the team should be worn. Team equipment includes bats, balls, catchers' masks, and chest protector.

Games are played for a predetermined number of innings or time limit. Each of the two teams plays on the offense (batting) and on the defense (in the field) during each inning.

Usually two officials (umpires) work each game. The plate umpire calls balls and strikes and is in charge of the game. The base umpire is on the playing field and determines if the runner is out or safe.

The game begins with a coin toss to determine the home team and visiting team. This may be predetermined by the game schedule.

THE SOFTBALL FIELD

The playing field is called the softball diamond. Its name came from the diamond shape of the infield, formed by the bases. The playing field should be level and free of obstacles. Most league fields are fenced.

A standard softball diamond is 60 feet on each side to first and third base (60 feet between bases). Lines extend straight out from home plate beyond first and third base to separate fair from foul territory. These lines extend to the fences. Fences are 175 to 275 feet from home plate.

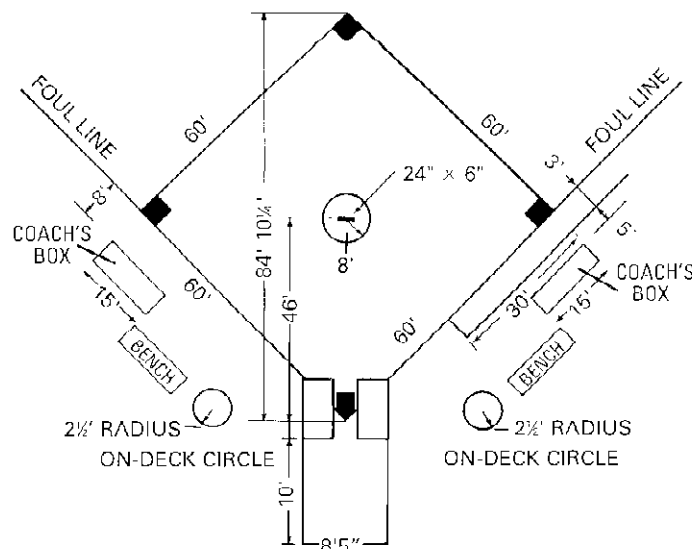

Standard softball diamond

The area around home plate and the catcher's box is a rectangle, 8 1/2 feet by 10 feet, containing the batter's box, catcher's box, and home plate. The batter's box is 7 feet by 3 feet. The catcher's box is 10 feet by 8 1/2 feet. Home plate is a pentagon shape, 17 inches wide by 8 1/2 inches by 12 inches.

An 8-foot radius pitcher's circle is positioned between home plate and second base. The distance from home plate to the pitcher's plate is between 40 and 46 feet (league determines). The pitcher's plate is a 6 by 24 inch rubber or wood block set flush with the ground.

Alongside first and third base, outside fair territory, are the coaches' boxes. These boxes are 3 feet by 15 feet.

On-deck circles are waiting areas for the next batter. They are 2 1/2 feet in radius and are located about halfway between the players, the bench, and the home plate area.

PLAYER POSITIONS

Defensive players are:

Catcher—Behind home plate.

First baseman—Covers territory around first base.

Second baseman—Covers territory around second base to the first base side.

Shortstop—Covers the territory around second base to the third base side.

Third baseman—Covers the territory around third base.

Right fielder—Covers the outfield area beyond first and second base.

Center fielder—Covers the outfield area beyond second base.

Left fielder—Covers the outfield area beyond third base.

Extra fielder—Used in slow-pitch leagues to cover any fielding area. Usually plays behind second base. The extra fielder is also known as the rover or the short fielder.

Pitcher—Delivers or pitches the ball toward the batter from the rubber inside the pitcher's circle.

Offensive players are:

Batter—Stands in the batter's box on the left or right side of home plate and attempts to hit the pitched ball into fair territory.

Base runner—Player who has reached first base before the fielding team can play the hit ball. Also, a player who has moved to second or third base.

FIELDING POSITIONS

1 Pitcher

2 Catcher

3 First baseman

4 Second baseman

5 Third baseman

6 Shortstop

7 Left fielder

8 Center fielder

9 Right fielder

10 Extra fielder

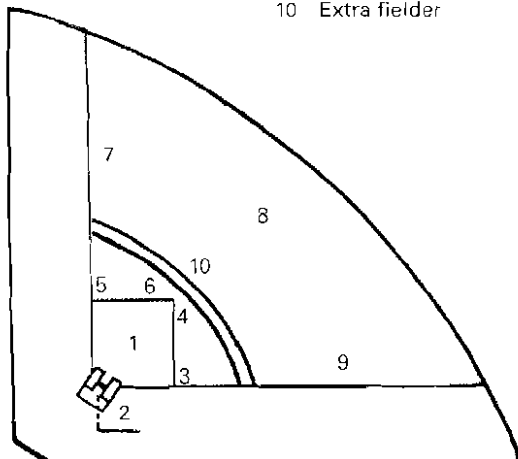

THE BALL

The softball is round, 12 inches in circumference, with a leather or synthetic cover weighing 6½ to 7 ounces. The ball's exterior is smoothly seamed, concealed stitched, or has a flat surface. It usually has a cork or kapok core, wound with a tight yarn and dipped in rubber cement before covering.

THE BAT

Bats come in many varieties to accommodate individual players' needs and preferences. Bats may not exceed specific lengths (league rules—usually 34 inches) and weights, and they must have a safety grip. Bats usually are made of wood or aluminum.

THE BASES

Bases are canvas or hard plastic bags, 15 inches square and 5 inches thick, that can be anchored to the ground.

PROGRAM FIELDS OF EMPHASIS

The following ideas will help you plan a well-rounded program. Program managers carry out these ideas with help from a team committee member.

ADVANCEMENT

- Review each Varsity Scout's advancement status.
- Conduct a Personal Fitness merit badge clinic.
- Monitor the team advancement chart regularly.

HIGH ADVENTURE/SPORTS

- Program manager outlines or updates the team's annual special high-adventure event (Philmont, Florida Sea Base, etc.).
- Conduct a Varsity softball activity.

PERSONAL DEVELOPMENT

- Have team members seek out family members and friends who have lived in other countries. Invite them to share their experiences with the team.
- Set up a "citizen now" conference. Invite a member of the judicial branch (local, state, or national) to address the current issues facing your community and how team members can influence the outcome.

SERVICE

- Set up and conduct emergency first-aid demonstrations for a select group in the community. The team decides who the select group will be
- Conduct a service project for your chartered organization.

SPECIAL PROGRAMS AND EVENTS

- As a Varsity Scout team, participate as “big brothers” for a troop of Scouts who have disabilities at a district or council event.
- As a team, go to a batting cage.

CONDENSED RULES OF SOFTBALL

The Playing Field: See diagram.

The Ball: Weight—6½ to 7 ounces; circumference—11¼ to 12¼ inches

The Bat: Single piece of wood, laminated wood, plastic, or metal. Maximum weight 38 ounces; must have safety grip.

Players: Teams have 10 players.

Substitutes: No limit in number. Player leaving game may return once, if that player started the game. Must take same position in batting order

Officials: Plate umpire judges all decisions on pitching and batting and controls the game. Base umpire makes decisions on plays at the bases

Duration of Game: Seven innings.

Starting Play: Teams toss a coin to decide which team bats first. The game begins on the umpire's call of “Play ball.” A minute is allowed for up to five warm-up pitches at the start of each half-inning and when one pitcher replaces another

Pitching Action. The pitcher should stand with one foot (the “pivot foot”) in contact with the pitching plate, and the other either on, in front of, or behind the plate: both feet must be within the length of the plate.

The pitcher must come to a complete stop facing the batter, with his shoulders in line with first and third bases, and the ball held in one or both hands in front of his body. This position must be held for one to 10 seconds. The pitcher may not begin to pitch until the catcher is ready and the umpire has given the signal. The catcher must remain in his box until the ball is batted or reaches home plate.

The pitch begins when the pitcher begins his windup. His pivot foot must remain in contact with the plate until the ball has left his hand. No step need be taken on the pitch, but any step that is taken must be forward, within the length of the plate, and simultaneous with the release of the ball.

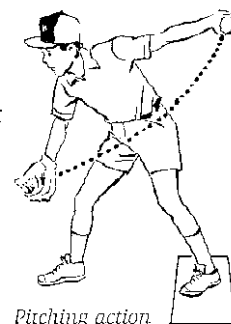

Pitching action



Pitching stance

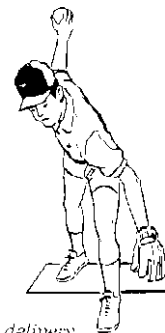

Pitching delivery

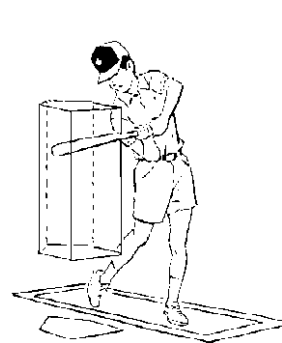

The strike zone

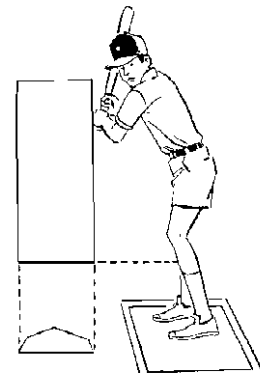

Batting stance

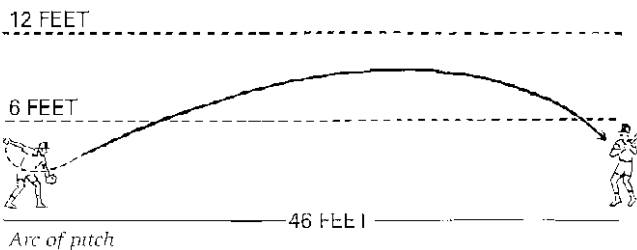

Arc of pitch

The ball must be delivered to the batter with an underarm motion, with the hand below the hip, and released at a moderate speed. The umpire is the sole judge of the speed of the pitch, and may call “illegal pitch” if a pitcher delivers the ball too fast. The pitched ball must travel in an arc that reaches its highest point 6 to 12 feet above the ground. It is an illegal pitch if the ball slips from the pitcher's hand during the windup or back swing.

Batting. The strike zone extends from the batter's knees to his highest shoulder in his natural batting stance and above home plate. A ball is called by the umpire if a pitched ball hits the batter outside the strike zone.

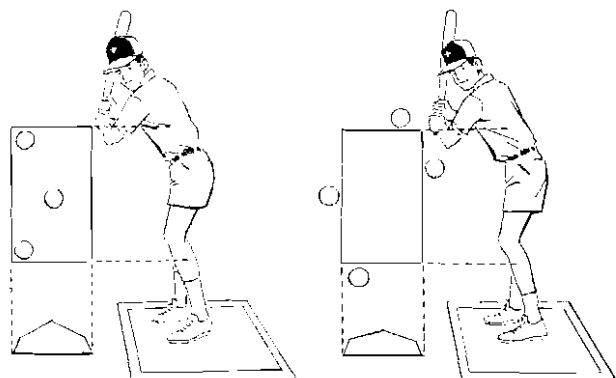

Pitches in the strike zone

Pitches missing the strike zone (balls)

A strike is called by the umpire for each foul ball not legally caught, even when the batter has already been charged with two strikes. The ball is dead after a strike or ball is called, and the runners may not advance.

A base on balls may be awarded at the request of the pitcher, who may ask the umpire to award the batter first base without pitching, or when four pitched balls have been called "ball" by the umpire. The ball is dead, and the base runners may only advance if forced.

The batter is out if: (1) a third strike is called against him; or (2) he bunts or chops the ball (strikes downward so that the ball bounces high into the air).

Runners may only leave their bases when a pitched ball has reached home plate or has been hit by the batter. Should a pitched ball reach home plate and not be hit by the batter, all runners must return to their bases. A runner who fails to keep contact with his base until the ball has reached home plate is called out.

If a pitch is an illegal pitch, the ball is dead. A ball is awarded to the batter, and the runners may not advance. If the batter swings at an illegal pitch it becomes legal.

A **no-pitch** occurs if the pitcher pitches

- during a suspension of play,
- before the batter is in position,
- when the batter is still off balance after a previous pitch,
- when a runner is called out for leaving base too soon,
- when a runner has not yet retouched base after a foul ball.

It is also a no-pitch if an opposing team member calls time in an attempt to make the pitcher commit an illegal pitch. In all cases, the ball is dead, and all subsequent action on that pitch is canceled.

An **illegal pitch** occurs if

- the pitching action is incorrect,
- the pitcher throws to a base without first stepping back from the pitcher's plate,
- the pitcher drops, rolls, or bounces the ball to stop the batter from striking it,
- the pitcher uses tape or other substances on the ball, pitching hand, or fingers, or wears a sweatband on the pitching wrist or forearm,
- the catcher is out of position when the pitch is released.

In all cases, the ball is dead, a ball is credited to the batter, and runners may advance one base without risk. A **wild pitch** is any pitch so high, low, or wide that the catcher cannot or does not stop or control it with ordinary effort.

A **passed ball** is a legally delivered ball that should have been controlled by the catcher with ordinary effort.

Delay. If the bases are empty and the batter not running, the catcher must return the ball directly to the pitcher, who must pitch again within 20 seconds. If catcher or pitcher act incorrectly, a ball is awarded to the batter.

Batting order. Players bat in the order given on the score sheets. Substitutes bat in the order of the players they replace. Even if a player's turn at bat ends with him out, he bats again on his turn in the inning. The sequence also carries over unbroken from one inning to the next. (If a player's turn at bat has not ended when his team's half-inning ends, he is first to bat in their next half-inning.)

Batting procedure. The batter must stand within the lines of one of the batter's boxes to receive each pitch.

The "strike zone," at which the pitcher aims, is the space above home plate between the top of the batter's knees and his armpits, in his natural batting stance.

Each legal pitch the batter receives is judged by the umpire to be either a "strike" or a "ball." A batter is allowed only three strikes on his turn; by the third, if not out, he must hit and run to first base or beyond. He must also run as soon as he hits a fair ball. But if he received four "balls" before having to leave home plate, he is allowed to advance to first base without risk.

A player's turn at bat ends when he is out or has advanced to first base or beyond. He is then followed by the next batter in order. A team's half inning at bat ends when it has had three players out while batting or running.

Strike is called by the umpire for each ball pitched into the strike zone (before touching the ground) that the batter misses or does not swing at, and for each foul tip.

In the case of a foul ball, the ball is in play and runners may advance at risk of being put out. A strike is also called, but the ball is dead and runners must return to their last bases, if (1) a pitch is struck at and missed and touches the batter; (2) a batter hits the ball against himself; (3) a pitch hits the batter inside the strike zone; (4) a foul ball is not legally caught on the fly and the batter has fewer than two strikes.

A **ball** is called by the umpire for each pitch that misses the strike zone and is not swung at by the batter, and for each pitch that is not swung at that touches the ground on or before home plate.

A ball is also called (1) if the catcher fails to return the ball directly to the pitcher, as required; (2) if the pitcher fails to pitch within 20 seconds; or (3) for each excessive warm-up pitch. In these situations, the ball is dead and runners may not advance.

Batted balls. The rules recognize certain types of batted balls.

- A "fly ball" is a batted ball that has not yet touched the ground or any object other than a fielder.
- A "line drive" is a fly ball that is batted sharply and directly into the playing field.
- A "bunt" is a ball not swung at but intentionally met with the bat and tapped slowly within the infield. Bunting is not allowed in slow pitch.
- A "foul tip" is a batted ball that goes no higher than the batter's head and is caught by the catcher.
- An "infield fly" (as judged and called by the umpire) is a fair fly ball (not including a line drive or attempted bunt) that can be caught by an infield player with normal effort, when first and second, or first, second, and third bases are occupied and there are fewer than two outs. On an infield fly, the batter is automatically out and the runners may advance at their own risk.
- A "fair ball" is one that (1) settles on or is touched on fair ground before first or third base, (2) bounds past first or third base on or over fair ground; (3) touches first, second, or third base; (4) touches a player or umpire while over fair ground; or (5) passes from fair ground over the fair boundary fence or hits a foul pole on the fly for a home run or two-base hit.

A batted ball that first hits foul territory and then rolls into fair territory without touching any foreign object, player, or umpire, is considered a fair ball. Except when a home run or a ruled dead ball two-base hit is scored, a fair ball is in play, and runners may advance. Other balls are foul balls, and usually the ball is dead and counts as a strike (as long as it does not take the batter's total above two strikes; if it does it is ignored and pitched again). But a foul tip or any other foul ball legally caught on the fly is in play.

Batter put-out. The batter is out, but the ball remains live and runner may advance at risk of being put out if (1) a fly ball (other than a foul tip) is legally caught; (2) a third strike (including a foul tip) is caught by the catcher; (3) the batter misses a third strike and the ball touches him; (4) on a third strike, there are fewer than two outs and first base is occupied, or (5) the batter hits an infield fly, regardless of whether the ball is caught (the "infield fly rule").

The batter is also out, but the ball is dead and runners may not advance if (1) he is not properly in position within 20 seconds of a "play ball" call; (2) he uses or enters the box with an illegal or altered bat; (3) he crosses from one box to the other when the pitcher is ready to pitch; (4) he hinders the catcher from fielding or catching the ball (unless a runner is put out, when the interference is ignored); (5) he hits a fair ball twice in fair territory; (6) he hits an "illegally batted ball" (see below); (7) a runner intentionally interferes with a fielder trying to catch a thrown ball or throw it to complete a play, in which case the runner is also out; (8) with any bases occupied (other than third only) and fewer than two outs, a fielder, for an attempted double play, deliberately drops a fair fly ball, there having been no infield fly call. The batter may also be put out when running, before reaching first base (see "Running").

An illegally batted ball occurs if (1) a batter's entire foot is completely out of the box when he hits the ball; (2) any part of his foot is touching home plate; or (3) he uses an illegal bat.

On-deck batter. The batter waiting to bat next stands in the on-deck circle near his bench. He may leave it to direct runners advancing from third base to home plate, but must not interfere with fielding.

Fielding. A fielder legally touches ("tags") a base when he touches that base with his body while holding the ball securely in his hand or glove. He legally touches ("tags") a runner when he touches that runner with the ball, or with his hand or glove holding the ball.

A **catch** of a fly ball is not completed until the ball is grasped by the fielder's hand or glove and is held long enough to prove he has complete control. If a ball has

hit anything other than the fielder or another fielder, it is not a caught fly ball.

Running. Runners must touch the bases in the correct order, including those they were awarded by the umpire. A base left too soon on a caught fly ball must be retouched before advancing to an awarded base.

If a runner must return to bases while the ball is in play, he must touch them in reverse order. A runner may not return to touch a missed base or one left illegally after (1) the ball has become dead; (2) a following runner has scored; or (3) he has returned to his team bench. Two runners may not occupy the same base simultaneously, and the runner who first legally occupied it is entitled to it. The other runner may be put out by being tagged with the ball. When a base is dislodged on a play, a runner need not follow it if it is unreasonably out of position.

The batter becomes a runner, with the ball in play and the risk of being put out, as soon as he hits a fair ball, or when the catcher fails to field a third strike before it touches the ground, and there are two outs or first base is unoccupied.

If four balls have been called, and the ball is in play, the batter becomes a runner but he advances to first base without risk (a "base on balls").

The batter is also awarded first base, but the ball is dead and runners may not advance unless forced (1) if a fair ball hits an umpire or runner on fair ground before passing any infielder; (2) if a fielder interferes with the batter striking at a pitch (unless the batting team chooses the result of play as it stood); or (3) if a pitch, not swung at and not called as a strike, hits the batter while he is in the box (unless he made no attempt to avoid it, in which case it is a ball or strike).

Batter out. Once he has started running toward first base, a batter is out if (1) after hitting a fair ball, or after the catcher has dropped a third strike, the batter or first base is legally tagged before he reaches first base; (2) he runs outside the 3-foot line and so interferes with a fielder throwing to first base; (3) he interferes with a fielder trying to field a batted ball or a dropped third strike; or (4) he intentionally interferes with a thrown ball or a play at home plate (if he is attempting to prevent a double play, the runner nearest home base is also out).

Runner out. A runner is out, but the ball stays in play if (1) while not touching a base, he is touched with the ball in the hand of a fielder; (2) he runs more than 3 feet to the side of the direct line between bases to avoid being touched; (3) he is forced to advance and a fielder tags him or the base; (4) he fails to return to touch the base last occupied after a suspension of play; or (5) he passes a preceding runner who is not out.

THESE RULES BY NO MEANS COVER EVERY LEGAL.
THE VARSITY TEAM MUST PLAY BY THE RULES
ESTABLISHED BY THE LEAGUE IN WHICH IT PLAYS.

SOFTBALL PRACTICE

During the season that the Varsity team is playing softball, practice sessions are held. Practice sessions can be held as part of the meeting or at a separate time. These sessions develop not only the physical side but also the mental side of the Varsity Scout.

Many opportunities will occur to blend the sport of softball with the game of life. Smart coaches and team captains use these opportunities to strengthen the individual Scout as well as the Varsity team. Practice sessions have four parts.

1. **Warm-up and conditioning exercises.** Simple warm-up exercises allow for loosening muscles and help in avoiding injuries. Vary the pace and type of exercise. Questions should be asked to stimulate thinking about proper eating habits and the importance of exercise throughout life. The portion of the meeting should take about 10 minutes.
2. **Skills development drills.** Teaching fundamentals is essential at every level of softball. Take time to teach basic skills at every practice session and plan simple drills to reinforce the points.

Players should work individually and in groups so that no one gets bored or slighted. Vary the player positions, allowing each Scout to learn all defensive responsibilities. Drills should be brief to keep things moving and to save time for scrimmage.

3. **Team talk.** Make this a regular, normal part of practice and use it as an opportunity for education and personal development. Team members should be encouraged to talk about such things as rules of the game and concepts of fair play.

These rules, principles, positions, tactics, and concepts apply to their everyday life as well as the sport of softball.

4. **Practice (scrimmage) game.** The warm-ups, skills development, and team talk should lead to the scrimmage. Team members enjoy this part of the meeting the most. Tie into the scrimmage what was just learned during the drills and team talk segments.

WARM-UP AND CONDITIONING EXERCISES

Healthy young players are always ready to play the game and rarely look forward to any preliminary “exercises.” It is important to avoid making the warm-up drudgery. Interpret its importance in helping get players ready for strenuous exercise. The warm-up exercises used and the attitude about them will strongly influence the Scouts’ lifetime attitudes about exercise.

Select new exercises for each practice, and also repeat some that have been done before.

To begin, players position themselves in a circle, in double lines, or in a semicircle facing the leader. Let players take turns choosing and leading exercise with the players.

Remember: Demonstrate the exercise or game first. Tell why the exercise is important. Have players do the exercise slowly together. Then exercise at regular speed.

STRETCHING EXERCISES

- **Deep breathing.** Ask players to take several deep breaths, expanding the chest fully by inhaling, then relaxing while exhaling.
- **Slow arm circles.** Walk in a circle. Swing arms forward and then backward.
- **Side benders.** Hands on hips, bend to one side, then the other.
- **Trunk twist.** Hands on hips, twist to one side, then the other.
- **Toe touching.** Touch opposite toe, with knees slightly bent.
- **Front thigh stretch.** Bend knee. Grasp shin bone and pull knee close to chest.
- **Back thigh stretch.** Bend knee and bring heel up toward back side. Grasp ankle and pull toward back side.
- **Neck rotation.** Gently rotate head from side to side.
- **Ankle rotation.** Rotate the foot without moving the knee, then with knee rotating.
- **Thigh and leg stretch.** Take position of sprinter on toes. Lower the hips to the ground without moving feet. Repeat each side.
- **Forward crawl stroke.** Stretch arms forward in crawling motion.

STRENGTHENING EXERCISES

- **Pull-ups.** Using an overhand grip on a horizontal bar, raise the body until the chin is above the bar. Lower the body slowly.
- **Sit-ups.** Lie on the floor. Pull the feet back, raising the knees. Place hands on the shoulders or behind the neck. Raise the body until the nose touches the knees.
- **Push-ups (modified).** Assume a hands-and-knees position on the floor. Bend the arms and lower trunk until the chin touches the floor.
- **Isometrics.** Ball squeeze - Squeeze a tennis ball in each hand. Hold for eight to 10 seconds. Repeat.

AGILITY EXERCISES

- **Shuttle run.** Run wind sprints for 60 feet, then turn around and return to start.
- **Footwork.** Standing with feet shoulder-width apart, run in place. Move left, right, forward, or backward on command of the exercise leader.
- **Jumping.** Place a 3-foot rod (dowel) between two cement blocks. Jump over the rod—back and forth, then left to right to left.
- **Jump rope.** Skip on both feet, on left foot, on right foot, alternate skip from left to right to both feet.

SKILLS DEVELOPMENT DRILLS

DRILLS FOR CATCHING AND THROWING

- **Toss-up.** A player tosses the ball in the air with one bare hand and catches it with both hands. Each successive throw is higher.
- **Clap catch.** Same as the toss-up, with the addition of clapping the hands while the ball is in the air.
- **Glove use.** Player puts on a glove and does the toss-up and clap catch.
- **Target throw.** A player throws a ball at a square or circle painted on a wall, starting at 10 feet and gradually increasing distance from the wall.
- **Two-player toss.** Two players face each other and throw the ball back and forth between them. Start at 15 feet and gradually increase the distance.
- **Speed throw.** Players in groups of two carry out the two player toss, throwing the ball between them as many times as possible in a 30-second time period.

DRILLS FOR FIELDING

- **Ground ball pairs.** In pairs, one player throws the ball on the ground to the second player. The second player runs forward to the right or the left to field the ball, and throws it back to the first player.
- **Pepper (basic).** One player uses the bat to bunt the ball to a group of players. The player who fields the ball tosses it back to the batter, who bunts it again to the fielders. Repeat over and over. Exchange the batter in rotation with the fielders.
- **Pepper (advanced).** Increase the distance from the batter to the fielders. The batter hits the ball rather than bunting. The player who fields the ball throws it back to the batter in an easy and accurate manner.
- **Fly-ball fielding.** The coach stands about 100 feet from the players and hits fly balls to them. The player who catches the fly ball throws it to the catcher on one bounce.

DRILLS FOR BATTING

- **Stance.** Players at an imaginary home plate practice alternate stances. The coach calls out “open stance”; “closed stance”; “regular stance.”
- **Batting tee.** Use a batting tee with players in pairs. The first player bats the ball from the tee, using various stances. The other player fields the ball. The swing should be easy and smooth.
- **Fungo.** Players take turns hitting a ball to teammates using a fungo bat. (A fungo bat is a lightweight bat that is longer and thinner than an ordinary bat. Use a regular bat if a fungo bat is not available.) Players should concentrate on swing development when batting, and on fielding development when catching the ball.

DRILLS FOR BASE RUNNING

- **Go for first.** Player takes a gamelike swing, drops the bat and runs to first base. The coach stands at first base and watches the player for straight-line running.
- **Go for two.** A marker is set 10 feet before first base. A player executes “go for first.” When the player reaches the marker, he cuts to the right and then turns sharply toward second base, tagging first and proceeding to second.
- **Combined.** The coach stands at first base. The player makes a swing and begins to run. The coach calls out “single” or “double.” The player executes the call.

DRILLS FOR PITCHERS

- **Hit the target.** Draw a 17 inch (width of plate) rectangle on a wall at about the average height of the players. The pitcher stands 40 to 46 feet (distance from home plate to pitcher’s plate) from the wall. The pitcher throws the ball at the drawn rectangle.
- **Motion.** The pitcher works on motion without a ball, picking out a target (plate) on the wall or on the ground, and going through the delivery motion.
- **Pairs.** A pitcher and catcher set up as if in a game. The catcher holds the mitt as a target. The pitcher tries to hit the target five times in the same position.

DRILLS FOR CATCHERS

- **Up, down, block.** The catcher wears full gear and assumes position behind the plate. Another player tosses the ball from about 15 feet away, throwing it straight, to the left, to the right, high, and on bounce. The catcher varies the way the ball is caught.
- **Pop-up, mask off.** A catcher in full gear assumes position. A coach or another player hits pop-ups. The catcher pushes the mask up, locates the ball, tosses the mask away from play, and goes after the ball.
- **Bunt grab.** A catcher in full gear assumes position. A coach or another player bunts the ball to the left, the right, and straight ahead. The catcher rushes out, fields the ball, and throws it to first base.

COACHING LEAGUE GAMES

Coaching softball games is a great opportunity to get closer to your team. It’s also an important time for the coach to model the kind of behavior expected by the team members.

BEFORE THE GAME

Start your team in a positive frame of mind.

- Remind them of the basic skills you’ve been working on in practice.
- Help them remember to think and play as a team.
- Suggest that they not worry about what their opponents might do, but concentrate on what they will do themselves.

- Review the important rules.
- Caution against arguing with officials on close calls.
- Discuss proper conduct on the bench and during warm ups.

Have the team do a few warm-up exercises before the game starts. Proper selection and use of warm-up drills is very important to effective team play. Warm-up drills may have a psychological as well as a physiological effect on a team. Players often need the opportunity to warm up muscles and become conditioned to the field environment. In addition, a well-planned and executed drill can boost a team's confidence and offer an impressive display of player skill and team organization. The pregame and preinning warm ups in this section may be used as presented or may be modified for use with different skill levels.

PREGAME BATTING PRACTICE

Approximately one hour prior to game time, each player should be allowed 10 to 15 warm-up hits. When the field must be shared, the home team practices in left field and the visitors in right field, with batters assuming positions in the field and fielders rotating clockwise to become the batter. To expedite the process, the right fielder should rotate to an on deck position. During the first few hits the batter should be concerned primarily with making contact and executing a fluid swing. Subsequent attempts should receive place-hitting emphasis.

PREGAME INFIELD WARM-UP

The coach fungo hits to infielders in the following sequence:

- A ground ball is hit to third base. The third baseman throws to first base. The first baseman returns the ball to third. The ball is then thrown to second, to first, and to the catcher.
- A ground ball is hit to the shortstop. The shortstop throws the ball to first. The first baseman throws to the shortstop covering second. The ball is thrown from second to first to the catcher.
- A ground ball is hit to the second baseman. The throw is made to first base. The first baseman returns the ball to the second baseman. The ball is thrown from second to first to the catcher.
- A ground ball is hit to the first baseman, who tosses to the second baseman covering first. The ball is thrown to the catcher and returned to the first baseman covering the bag. The first baseman throws to the catcher.
- A ball is bunted a short distance in front of home plate. The catcher fields the ball and throws to first. The first baseman throws back to the catcher covering home.
- A ground ball is hit to each infielder who tags or throws to the closest bag and completes one of the following double plays: second to first, third to second, first to third, home to second.

PREGAME OUTFIELD WARM-UP

While infielders are warming up, the following outfield drill should be conducted. A batter standing on the outfield foul line fungo hits balls to players in a shuttle-line formation. In turn, each player catches the ball and returns it to a catcher beside the fungo batter and takes a position at the end of the line.

Toward the end of the infielders' practice time, the starting outfielders take their respective positions on the field and participate in the following drills, which complete their warm-up.

- A fly ball is hit, respectively, to the left, center, and right fielders. The fielders return the ball to the catcher on the first bounce.
- A fly ball is hit to the left and center fielders. The fielders throw to second baseman covering second. The ball is relayed from second, to first, to the catcher.
- A ground ball is hit to each infielder. The infielder throws the ball to the catcher and charges toward home. The catcher then rolls a second ball back to the charging player. The second ball fielded is tossed easily to the catcher, and the player continues off the field. Outfielders are hit short balls. Each fielder catches the ball, throws it to the catcher and runs off the field.

DURING THE GAME: PREINNING WARM-UP

As the pitcher warms up by pitching the legal number of pitches to the catcher, the first baseman throws ground balls to the third baseman, shortstop, and second baseman. Each infielder fields the ball and throws to the first baseman. The outfielders take their positions in the field and practice throwing in relay formation to one another. The left fielder throws to the short fielder, the short fielder to the center fielder, the center fielder to the right fielder. The process is then repeated in reverse order. If the defensive team's bench is on the first baseline, the right fielder assumes responsibility for starting the warm-up. An alternative slow-pitch warm-up involves the left fielder and center fielder throwing to each other, while the short fielder and right fielder do likewise.

PREVENTION AND CARE OF INJURIES

Softball is a relatively safe sport for players, but since it involves bodily contact, injuries may occur.

All Varsity team sports are as safe as the environment established by adult leadership for the sport. Softball coaches should take precautions to help prevent injury and be prepared to respond when they do occur.

SAFETY CHECKLIST	
<input type="checkbox"/>	Facilities are in good repair and clear of obstructions around the court.
<input type="checkbox"/>	Teams warm up properly prior to practice sessions and games.
<input type="checkbox"/>	Rules and equipment are modified to adjust the physical demands of the sport to the developmental level of players.
<input type="checkbox"/>	Teams are properly supervised and coached during practice sessions and games.
<input type="checkbox"/>	Coaches know the proper emergency steps to take when accidents do occur.
<input type="checkbox"/>	Players do not play when hurt.
<input type="checkbox"/>	Players are taught how to prevent blisters by wearing footwear that fits properly, gradually breaking in new shoes, and wearing two pairs of socks, if needed.
<input type="checkbox"/>	Players are taught to treat bruises and sprains with ice packs to reduce swelling and pain.
<input type="checkbox"/>	Practice sessions are reasonable in length and planned to include brief rest periods.
<input type="checkbox"/>	Game rules are enforced by officials and excessive fouls are avoided.
	The emphasis should be on prevention of injury through proper warm-up, conditioning, supervision, and education.
	Players should be conditioned properly for game play. When injuries do occur, it is necessary to be familiar with the immediate recommended treatment. First aid is the immediate handling of athletic injuries. If pain persists, refer to family physician for follow-up.

Injury	Suggested First Aid
Muscle pulls, sprains, and bruises	Use ice pack immediately to reduce swelling. Speed of application is essential.
Small cuts	Apply pressure to reduce bleeding. Wash with cleaning solution and apply sterile dressing if necessary.
Nosebleed	Have player pinch nostrils and hold until bleeding stops. Apply ice pack.
Foreign body in eye	Pull upper lid down, holding eyelash. Wash out with eye-cleaning solution. If substance is not removed, refer to physician.
Fainting or loss of wind	Rest in cool place. Try to relax player and slow down breathing.
Scrapes and burns	Wash with cleansing solution. If necessary, cover with gauze.
Elbow or knee injuries; jammed finger or toe	Elevate area and apply ice pack. Refer to physician if pain persists.
Shin injury	Apply ice pack and compression. Refer to physician if pain persists.
Back or neck injury	Keep the player calm. Do not allow the player to move or sit up if pain is severe. If pain is slight, apply ice pack.
Blisters	Keep clean, wear two pairs of socks, puncture if necessary to relieve pressure. Remove dead skin for quicker healing.

Remember: Never send a hurt player back into practice or a game. First aid is the immediate handling of athletic injuries. Refer a hurt player to the family physician for follow-up treatment if pain persists.

GLOSSARY OF SOFTBALL TERMS

Aboard. A player on base is said to be "aboard."

Assist. A fielding credit earned by a player who helps a teammate make a put out. Should the teammate fail to make the put-out because of a misplay, the first player is still given credit for an assist.

Away. The number of outs, such as "one away" instead of "one out."

Backstop. While a catcher is often called "the back-stop," the term is more often applied to the fencing behind the plate.

Backup. A fielder taking position behind another fielder to stop the ball in case of an error.

Bag. A base. Also called "sack," "hassock," "pillow," "canvas," etc.

Ball. A pitch that is not in the strike zone of a batter and that the batter does not attempt to hit.

Base. The four "stations" on a ball field that runners on the offensive team must touch in succession before scoring—first base, second base, third base, and home base (known as home plate).

Base hit. A batted ball that allows the batter to reach a base safely, provided that he does not reach first base through a fielding error or a fielder's choice and provided that no other runner is forced out.

Baseline. An imaginary space, 6 feet wide, within which a runner must stay while running bases. If the runner flagrantly moves outside of the lane, he can be called out unless he is trying to avoid a fielder who is attempting to catch a batted ball.

Base on balls. The penalty imposed on a pitcher who delivers four "balls" to a batter. The batter is allowed to go to first base. Also called a "walk."

Bases full. Base runners on first, second, and third base. Also known as "bases loaded," "bases jammed," "three men on," etc.

Base path. An imaginary line 3 feet on either side of a direct line between the bases.

Bat. A regulation softball bat must be one piece of wood or other approved material. Bats are constructed in a variety of lengths and weights. Check your league rules for size and weight requirements.

Batter's box. The area in which the batter must stand. There is a batter's box on each side of home plate. Each is 7 feet long, 3 feet wide, and placed 6 inches from home plate.

Batting average. The number of hits divided by the number of times at bat. The result is usually expressed in three decimals.

Batting order. The order in which players take their turns at bat. It is set before the game begins and cannot be changed during play. However, player substitutes can be made.

Beat out. To hit a ball to an infielder and reach first base ahead of that fielder's throw, for a hit.

Bleeder. A batted ball that just trickles past the defensive player for a "weak" base hit.

Blooper. A batted ball that arches over the heads of the infielders and drops in front of the outfielders for a base hit.

Bobble. Fumbling the ball while attempting a catch, or dropping the ball for an error.

Bottom. The second part of an inning

Box score. A description of the events of a game kept in condensed form by the use of certain symbols for the various types of possible plays.

Catcher. The defensive player who stands behind home plate to receive balls thrown by the pitcher.

Center fielder. The defensive player who guards center field, the outfield area beyond second base.

Chest protector. A device used by a catcher or plate umpire to keep hard-thrown or hard-hit balls from causing injury.

Choke. A "short" grip. Moving the hands up the bat, toward the "trademark," for better control in hitting.

Circuit clout. A home run. Batter circles all four bases.

Clean the bases. To hit a home run with players on base, then clearing all the bases of runners.

Cleanup. The fourth position in the batting order, usually given to the best hitter on the team on the theory that that player will drive in more runs.

Coach. A member of the team who stands near either first or third base to give base-running instructions to the team's players.

Complementary runner. A substitute base runner, who by mutual consent of the opposing coaches or managers does not prevent the original runner from remaining in the game.

Corner. Portions of home plate; the part of the plate closest to the batter is known as "the inside corner." The part farthest from the batter is known as "the outside corner."

Count. The number of balls and strikes on a batter.

Covering the base. Assuming a baseman's position and responsibility when a put-out could be made at the base.

Crowding the plate. A batter moving close to the plate and refusing to back away with the pitch.

Curve. A ball pitched with spin to move in a curve rather than a straight path.

Cut. To swing at a pitched ball. Also, a ball that passes over a corner of home plate is said to "cut the corner" for a strike.

Cutoff. An infielder's interception of a throw from an outfielder or another infielder when no play can be made at the intended base, or when another play is foreseen.

Dead ball. A ball no longer in play.

Deep. A defensive player who stands some distance beyond his usual playing position is said to be playing "deep." Opposite to "shallow."

Deliver. To pitch the ball.

Diamond. The area formed by the four bases.

Die. To be stranded on a base as the third out is made.

Dominant hand. The hand that is preferred for throwing.

Double. A base hit on which the batter is able to reach second base safely despite errorless fielding by the defensive team.

Double play. A defensive maneuver resulting in two outs in one play.

Double steal. Two runners steal bases on the same play. Stealing is not permitted in slow-pitch.

Down. Denotes outs. "Two down" means that there are two outs.

Drive. A hard-hit ball that travels in a fairly straight line.

Earned run. A run that was scored through offensive play rather than through a defensive error.

Earned run average. The average number of earned runs that a pitcher allows during a full game. To find the earned run average, divide the number of earned runs allowed by the number of innings pitched and multiply by seven.

Error. Any defensive misplay that allows a batter to remain at bat longer than he should, or a base runner to remain on base longer than he should, or a runner to reach base or take an extra base.

Extra-base hit. A base hit on which the batter gets more than one base.

Fair ball. A batted ball that is touched and stops in the infield between the foul lines, or that initially lands between the foul lines beyond the bases.

Fielder's choice. A play in which a fielder, after taking a batted ball, elects to make a play on a base runner rather than on the batter.

First base. The base to which the batter runs after hitting the ball. It is either 55, 60, or 65 feet (depending on league rules) from home plate, along the right-field foul line.

First baseman. The defensive player who covers the territory around first base and who generally retires a large number of batters by receiving the throws of the other infielders after the batter has hit a ground ball.

Fly. A ball that is hit into the air, usually to the outfield.

Force-out. An out occurring when a defensive player in possession of the ball touches any base before a runner who must reach that base touches the base.

Forfeit. An umpire may forfeit any game and award it to one team for a variety of reasons, such as delay of game, refusal to continue play, rule violation, etc.

Foul ball. A batted ball that is touched or stops outside of the foul line between home plate and first or third base, or that bounces past first or third base in foul territory, or that first lands outside the foul lines on a fly ball past first or third base. A foul caught on the fly is an out for the batter. The first two foul hits in a time at bat count as strikes; succeeding ones do not in fast-pitch. A batter making a third foul hit in slow-pitch is out. A foul bunt attempt after two strikes is an out for the batter in fast-pitch.

Foul line. A 3-inch white line extending from home plate out to the boundaries of the playing field. The two foul lines form right angles at home plate. The foul line itself is considered fair territory.

Foul tip. A foul ball caught by the catcher immediately after leaving the hitter's bat on a direct line into the catcher's hands. Any foul tip is a strike and, in fast pitch, the ball remains in play.

Full count. A count of three balls and two strikes on the batter.

Fungo. A high fly, usually hit by tossing the ball from the hand and then hitting it, to give the fielders practice.

"Give" with the ball. To relax the arms, hands, and fingers as the ball enters the hands or glove.

Grand slam. A home run with the bases loaded.

Grounder. A "grounder" or "ground ball" is a batted ball that hits the ground as soon as it leaves the player's bat and bounces in the infield as it moves toward the outfield.

Hit. A legally batted ball that results in the batter successfully getting on base through no error by the defensive team.

Hit the dirt. To slide.

Hitting behind the runner. The act of placing the ball to an area of the field momentarily passed by an advancing base runner.

Hole. An area not covered by a defensive player. Fielders often shift positions against certain batters, leaving large "holes" open that normally do not exist.

Home run. Short for "home run." A base hit whereby the batter runs all the bases and scores a run. Most home runs result from balls hit over the outfield fences. Some result from fast base running following a ball hit well out of outfielders' reach but within the playing area.

Hook slide. A base-running maneuver in which the runner, trying to reach a base on a close play, slides feet-first into the base and twists his body away from the defensive player to touch the base with his rear foot.

Infield. Generally, that fair territory bounded by and including the base paths.

Infield fly. A ball hit in the air into fair, infield territory that can be caught by an infielder. With fewer than two outs and base runners on first or second or on first, second, and third, the infield fly rule is in effect.

Infield hit. A base hit that does not go past the outfielders to the outfield.

Inning. A division of a game. An inning is divided into two halves, each team is allowed three outs as the offensive team.

Inside. A pitch that misses the plate on the side closest to the batter.

Interference. A hindrance by a player that prevents the opponent from making a play.

Leadoff (player). The player who first bats for his team either in the regular batting order or at the beginning of an inning.

Left fielder. The defensive player who covers the outfield area beyond third base and shortstop.

Line drive. A ball batted sharply to travel in a fairly straight line. Also a "clothesliner."

Mask. A device worn by catchers and umpires to protect their faces against injury from a batted or thrown ball.

Obstruction. A defensive player, not involved in the play, interfering with the progress of an advancing base runner.

One-two-three. Side retired without a batter reaching first base.

Opposite field. Directing the ball to the field of the batter's dominant side, caused by swinging late.

Opposite hand (side, foot, arm). The hand on the opposite side of the dominant or preferred hand.

Out. The retirement of a batter or base runner during play. The ways in which a batter or base runner may be put out are numerous. Each team is allowed three outs during its time at bat in any one inning.

Outfield. In general, the fair territory beyond the infield.

Outside. A pitched ball that misses the strike zone on the side of the plate farthest from the batter.

Overrun. To run past a base or to slide past (overslide) a base, placing the runner in danger of being tagged out. However, the batter may overrun first base while attempting to reach it after hitting the ball.

Pick off. To trap a runner off base with a sudden throw and tag him out.

Pinch hitter. A player who is sent into the game to bat in place of another player.

Pivot foot. The foot that the pitcher must keep in consistent contact with the pitcher's plate until the ball is released.

Pivot person. The player, sometimes referred to as the middle person, who covers second base in a double-play attempt.

Place hit. A batted ball that is intentionally hit to a specific area of the field.

Pop-up. A short, high fly in or near the infield that can be easily caught.

Pulling the ball. Hitting for the field of the batter's non-dominant side. For a right-handed batter, directing the ball to right field by hitting late and following through.

Put-out. The retiring of a player or base runner.

Replay. An assisting throw by an infielder, or another outfielder, when a long throw is necessary from an outfielder to the infield.

Right fielder. The defensive player who covers the outfield area beyond first base and second base.

Rounding the bag. A curved advance toward the next base by a base runner after safely passing a base.

Run. A run is scored when a runner touches home plate, having previously touched first, second, and third bases. The run is counted provided the runner is not forced out or tagged out, or the batter is not retired for the third out of the inning.

Rundown. A defensive play designed to tag a base runner trapped between two bases.

Runs batted in (RBI). A batter is credited with batting in a run when a base runner scores when he makes a base hit, makes a sacrifice, forces in a run by walking, or hits into a put out.

Sacrifice. A batted ball that intentionally advances a base runner, but results in the batter being put out.

Scratch hit. A ball, usually weakly hit, that none of the fielders can reach in time to retire the batter.

Second base. The next base after first base. It is the only base not touching the foul lines.

Second baseman. The defensive player who generally covers second base and the area to the first-base side of second.

Shoestring catch. A ball caught just above the shoe tops or inches from the ground.

Short hop. Catching a ball just as it rebounds from the ground.

Shortstop. A defensive player who generally covers second base and the area to the third-base side of second.

Shut out. To prevent the opposing team from scoring a run.

Single. A base hit on which the batter reaches and stops on first base.

Slide. Sliding along the ground toward the base to avoid being put out.

Straightaway. Assuming a stance for hitting the ball through the central area of the diamond or field.

Strike. A penalty imposed on the batter for either failing to hit a ball that enters the strike zone; swinging at any pitch and missing it; or hitting a foul ball that is not caught on the fly.

Strike zone. The area over the plate between the top of the batter's knees and the shoulders when the batter assumes a natural stance.

Tag. Making a putout on an advancing base runner by touching the player with the ball.

Tag up. The action of a base runner in touching a base while a fielder is catching a fly ball. The runner must do so if he desires to advance to the next base without danger of being put out at the base from which he leaves. If he leaves this base before a fielder catches the ball, he can be put out providing a defensive player touches this base with the ball in his possession before the runner returns to tag the base.

Texas leaguer. A looping ball hit between the infielders and the outfielders.

Third base. The next base after second base. Its outside edge touches the left-field foul line. Next stop is home plate.

Third baseman. The defensive player who covers the area around third base.

Throwing behind a runner. A misplayed attempt to put out a base runner by throwing the ball to a base that the runner has passed.

Top. To hit the top portion of the ball so that the ball bounces downward sharply, resulting in a weak ground ball.

Trap. To catch a ball immediately after it has taken its first bounce.

Triple. To make a three-base hit.

Triple play. The retirement of three offensive players between the time a ball leaves the pitcher's hand and is returned to him in the pitcher's box.

Walk. A base on balls. Also called a "pass," a "free ticket," a "gift," etc.

SURVIVAL CONTENTS

Background	45
Program Fields of Emphasis	45
Survival Priorities	46
Finding Your Location	47
Shelter	49
Fires	50
Food	52
Snares	52
Fishing	53
Survival Kits	54
Signaling	55
Water	56
Resources	57

SURVIVAL

BACKGROUND



So far in your Scouting experience you have learned some basic outdoor skills and possibly some survival skills. You might even have earned the Wilderness Survival merit badge. In this activity, you will go beyond these basic and intermediate levels to work on advanced skills that require individual and team efforts. As you develop these skills toward the ultimate adventure, you will have an opportunity to get to know yourself and members of your crew and to draw on resources you haven't used before.

This chapter provides the "how to" for knowing your location. You will become proficient in building snares, catching for fish with natural materials, displaying distress signals, and making survival kits.

Varsity Scouts will learn that survival situations are not limited to the wilderness. Their experience in this feature will prepare them to appreciate teamwork and to better understand nature and the environment.

Keep in mind that we are not trying to turn you into a combat soldier or Superman. Your goal should be to develop problem-solving skills and develop self-confidence. You will learn how to work with the environment and to see how nature can help us live in better harmony with each other.

- S** Size up the situation
- U** Undue haste makes waste
- R** Remember where you are
- V** Vanquish fear and panic
- I** Improvise
- V** Value living
- A** Act only after thinking
- L** Learn basic skills

PROGRAM FIELDS OF EMPHASIS

The following ideas will help you plan a well-rounded program. Program managers carry out these ideas with help from a team committee member.

ADVANCEMENT

- Review each Varsity Scout's advancement status.
- Conduct a Wilderness Survival and/or Emergency Preparedness merit badge clinic.
- Monitor the team advancement chart regularly.

HIGH ADVENTURE/SPORTS

- Program manager outlines or updates the team's annual special high-adventure event (Philmont, Florida Sea Base, etc.).
- Conduct a survival activity.

PERSONAL DEVELOPMENT

- Have a cardiopulmonary resuscitation (CPR) course conducted by the American Heart Association or American Red Cross.
- Obtain information about fall, winter, spring, and summer night skies from a library, the Internet, or other source. Location of the stars will help you find your way without a compass.

SERVICE

- Set up a workshop in your neighborhood to teach basic emergency survival skills to adults and children. These skills could include emergencies that might occur because of weather conditions in your community.

SPECIAL PROGRAMS AND EVENTS

- Conduct an environmental study for your community, pointing out to local officials concerns the team may have.
- Contact several other teams to plan a survival week end encampment. Depending on the season, keep personal gear to a minimum.

SURVIVAL PRIORITIES

Knowing priorities in an emergency lets you start to work immediately and without confusion. Below are listed the logical steps to take in an emergency situation. Later, each item will be studied in detail.

- 1. Positive mental attitude.** As attested by those who have survived wilderness emergencies, a positive mental attitude may be the most essential element in survival.
- 2. First aid.** If an injury is life-threatening, such as rapid loss of blood, first aid becomes the most important thing to do.
- 3. Shelter.** Extreme weather conditions, too hot or too cold, make finding or building a shelter of top importance. At such times even painful but minor injuries must wait until shelter is available. This is even more urgent if night is approaching.
- 4. Fire.** Often, along with shelter, you will need a fire for warmth and signaling. Fuel should be secured and the fire started before dark.
- 5. Signaling.** When you have taken steps in dealing with the emergency, you will need to prepare rescue signals.
- 6. Water.** Under all circumstances, water is essential. You can live only a few days without it.
- 7. Food.** A person can live several weeks without food; it does not rate high as a survival priority.

POSITIVE MENTAL ATTITUDE

Survival is largely a matter of a positive mental outlook. The will to survive is the most important factor. History is filled with accounts of ordinary people who endured intense heat and cold, and overcame hunger, thirst, pain, and loneliness. With the right frame of mind, a person can survive for a long time with a minimum of shelter, water, and food. No one can survive without hope. Panic is the most destructive response to a survival situation. It can lead to hopelessness, which can lead to a breakdown in the will to survive. Knowledge of survival techniques can instill confidence in survival situations.

Most people immediately become concerned about starving to death. With adequate water, you can go about a month without food. For the first three days without food, you literally are fasting and will experience hunger pains, headaches, and dizziness. After that, hunger pains will go away for about three weeks. Without food, the body needs several quarts of water a day.

The bottom line for every survival situation: Never give up.

BEFORE YOU GO

Before you go, you should prepare a trip plan and leave it with a responsible person. Below is a sample of the information that should be listed.

SAMPLE TRIP PLAN	
Trip Plan of _____	
Date and Time of Departure: _____	
Date and Time of Return: _____	
Destination: _____	
Adults Who Will Go Along: _____	

Route Going: _____	

Route Returning: _____	

Permits Required: _____	

Special Equipment Needs: _____	

Special Clothing Needs: _____	

CLIMATE AND ENVIRONMENT

Depending on where you live, you are going to have any of a variety of situations to deal with. Natural resources will vary along with the climate. You will have to adapt survival techniques to your environment.

DECISION MAKING

One of the most important keys to survival is keeping a clear mind so that you can analyze the situation and solve the problems that are at hand. Your best tools in dealing with any challenge are your brain and common sense. Every action you take should have a purpose and a calculated result. Survival is like a giant chess game: Every move you make can have a counter-move, so you must anticipate the counter-move.

The bottom line to all of this is that the techniques you use in this activity you will use for the rest of your life.

FINDING YOUR LOCATION

USING POLARIS

In the northern hemisphere, one star, the North Star, is never more than roughly one degree from the celestial north pole. In other words, a line from any observer north of the equator to Polaris will never be but slightly more than one degree from true north. This single night star has saved more lives than any other.

The easiest way to locate Polaris is by finding the Big Dipper, usually prominent in the northern sky. The two stars on the outer edge of the Big Dipper, called the pointers, lead the eye upward almost exactly to where the pole star twinkles by itself.

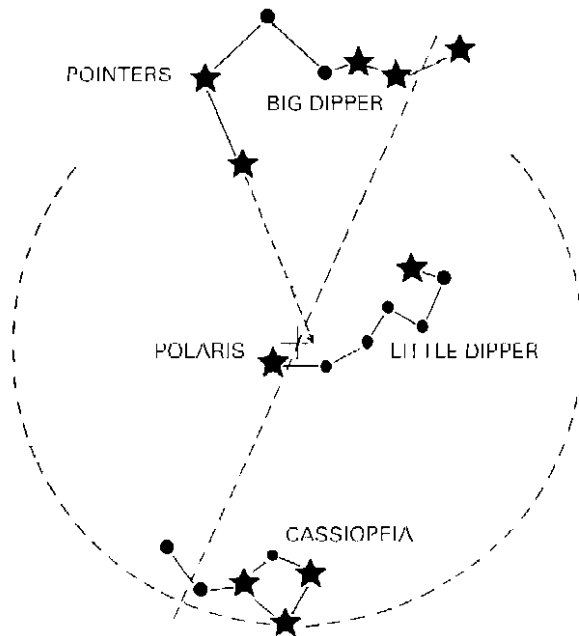

To find the North Star, first locate the Big Dipper.

USING SHADOWS

You have no compass. You have no watch. The sun is bright; it is morning. You want to find out exactly where true north lies.

Push a short pole into the ground, making sure that it is vertical by holding a weighted string beside it. Then loop a string, lace, thong, vine, etc., around the base of the pole.

Holding this taut, measure the length of the pole's present shadow. Then tie or hold a sharp stick to the line at this precise point. Draw a half circle, starting at the tip of the present shadow, or mark this point with a stake.

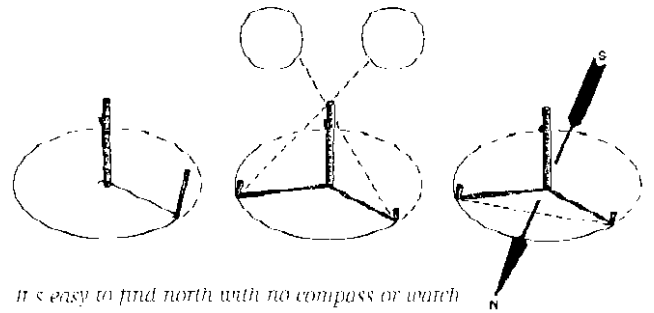

It's easy to find north with no compass or watch.

The shadow of the pole will shorten until it is noon by local standard time. Then it will start lengthening again. Watch for the moment it once more meets the arc. Mark this point with a second stake.

A line connecting the pole to a point halfway between the first and second marks will run north and south. (See "North or South," below.)

USING SHADOWS ANOTHER WAY

Again, sometime before midday, drive a rod vertically into the ground, checking the alignment of the stick with a makeshift plumb bob. Mark the end of the present shadow with a peg or stone.

Keep marking the end of the shadow as the shadow shortens, then begins lengthening again. The shortest shadow will run north and south. However, even with this method the north-south line must be found by selecting a point halfway between two shadows of equal length.

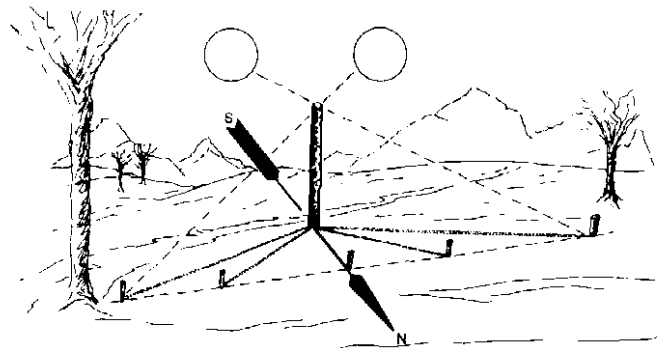

Using the sun's shadow to find north.

NORTH OR SOUTH

Whether the sun is north or south of you at midday will depend, of course, on your latitude. If you are north of 23.4 degrees, the sun will always be due south at noon. Therefore, its shadow will point north. If you are south of 23.4 degrees, the sun will always be due north at noon, and its shadow will point south.

WHERE IS WEST?

There is an even faster method for telling direction from shadows. All you need is sunlight or moonlight strong enough to cast a shadow. Press or drive your pole or stake into the ground as you did before. Mark the top of the shadow with a pebble or twig. Five or 10 minutes later, mark the top of the new shadow. A line joining the second mark with the first will point generally west in the northern hemisphere.

With the sun, this method is surprisingly accurate during the middle of the day. The line runs a bit south of west in the morning. In the afternoon it tends somewhat north of west. During a day of travel by this method, however, these inaccuracies will average out.

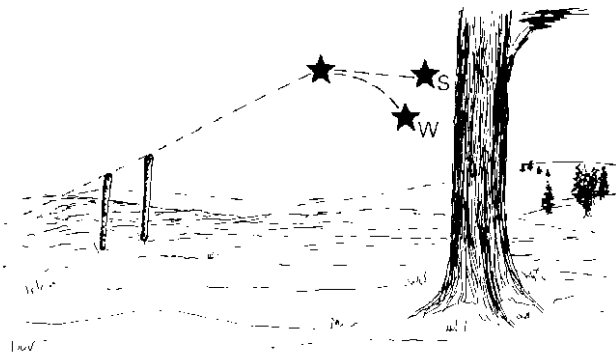

Determining direction by the stars

FOLLOWING THE STARS

Begin by taking a sight on any star. The brighter ones will be easier to follow. Of course, the orb's movement will be too slow for anyone to detect just by glancing at the sky. You'll need two fixed points over which to look. These may be two pegs driven into the ground with their tips lined up accurately. If you watch a star over these markers for several minutes, it will seem to be falling, rising, or swinging left or right.

If your star appears to be falling, it is situated just about west of you. If the star gives the appearance of looping flatly toward your right, you are facing approximately south. If it appears to be rising, you're heading just about east. If it gives the impression of swinging flatly toward your left, then you are facing north.

Watch several stars to verify the direction. Then mark north with a slanting stick or scratched line so that you can head in the right direction in the morning.

FINDING NORTH IN THE ARCTIC

Hang a rock from the end of a stick slanted into the ground or snow at a 45-degree angle, as shown in the illustration. Some time before noon, mark the spot where the rock's shadow falls.

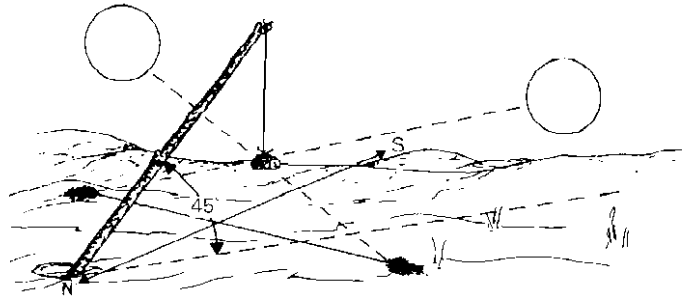

Finding north in the Arctic

Approximately six hours later, mark the spot where the rock's shadow is cast by the afternoon sun. Draw a line from the point precisely beneath the suspended rock through a point halfway between the morning and afternoon marks. This line will point to within 3 degrees of true north.

NATURAL SIGNS SHOWING DIRECTION

In open country, snow and sand drifts are usually on the lee, or downwind side, of protruding objects like knolls, high banks, rocks, trees, or clumps of willow. If you know what direction the wind was blowing when the drifts were formed, you'll have a direction indicator directly in front of you as you travel. In any event, the angle at which you continue to cross drifts will serve as a checkpoint in maintaining a course.

Knowing the direction of the prevailing wind can also be valuable in country where there is considerable deadfall, perhaps after a fire. Take into account, though, the results of unusual storms and the air deviations caused by hills, gorges, etc.

The snow on the south side of knolls, ridges, and the like tends to be more granular than on the north. Knowing this, you can maintain direction, even when the sun is not shining, if no new snow has fallen since it shone last.

In the barren and semibarren lands of eastern Canada, windblown trees point to the southeast because of the prevailing wind. The prevailing wind will also blow away the snow at the bases of drifts to give them anvil-like shapes. These snow anvils point to the northwest.

There is also the compass plant, sometimes called pilotweed or rosinweed. This plant has leaves that are attached directly at their bases, instead of by stems, to stalks 5 to 12 feet high. These leaves hold their edges vertically, generally pointing north and south. The yellow flower heads, several inches across, resemble those of a wild sunflower.



The compass plant's leaves point north and south

Willows, poplars, and alders tend to lean toward the south, unless the prevailing winds turn them in another direction. Similarly, the tops of such trees as pines and hemlocks naturally point to the east.

The age rings revealed in standing stumps are generally widest on the southern side if this has been the sunniest side. To make sure of your direction, select several stumps of trees so situated that they would have been in the full warmth of the noonday sun, and then average the results.

Pines, spruces, hemlocks, and other softwoods tend to be bushiest on the south side. Look for single coniferous trees growing apart from others. The bark of poplar trees is whitest on the south side and darkest on the north side.

Anthills are always found on the south side of trees and other objects.

All vegetation also tells its own tale, growing taller and more open on northern slopes, and smaller and denser on a southern exposure.

Then there is the story told by moss. It does, indeed, thrive most thickly on the shadiest side of trees, which, if these are in the open where the sunlight can touch them all day, will be on the north. However, certain lichens that resemble moss to anyone who does not examine them closely grow best on the sunniest portions and could trip you up.

SHELTER

Unless the climate is mild, day and night, one of the first requirements in a survival situation is shelter from the elements. If your pack contains a tent or tarp, all you need to do is find a suitable location. If you were traveling by vehicle, the car or truck offers protection. Even a canoe or boat can be propped up to make a shelter

If you have none of the above, then you must either find a natural shelter or make a shelter from the materials at hand.



NATURAL SHELTER

Caves are natural shelters, providing they are free of snakes, bears, and other wildlife. Fallen trees, hollow trees, boulders—they all can be used. Natural shelter is especially important if darkness is falling and there is no time for shelter construction. Train your eyes to recognize instant natural shelters. You will be surprised at all that nature provides, if you look closely enough.



MAKING A SHELTER

Before making a shelter, locate the right site for it. It should be relatively level but sloping enough and high enough to provide adequate drains. The site should not be exposed to wind or drifting sand or snow. If you will be building your shelter from native materials, is there a good supply of them nearby? The closer they are, the less energy you will use procuring them. Is there a plentiful supply of firewood? Be careful to avoid dead snags or branches. Also evaluate any risk of rock falls, landslides, avalanches, or lightning.

A good site will be near water—one of your priorities for surviving—but not so near that you may be threatened by flash floods, insects, shifting river courses, or high tides. Visibility from the air should be considered for aircraft flying overhead to pinpoint your location.

A fallen tree or log; a large rock outcrop or an exposed root base; thickly vegetated brush or small spruce, fir, or pine trees; a snapped-off sapling or a lashed tripod can all be used to improvise a shelter. Always remember that a small shelter takes less work to build and less area to heat. *Build the smallest shelter that is adequate for your needs.* A shelter 7 feet long, 3 feet wide, and 2 feet high is large enough for most survival situations. You will probably only use it a night or two anyway.

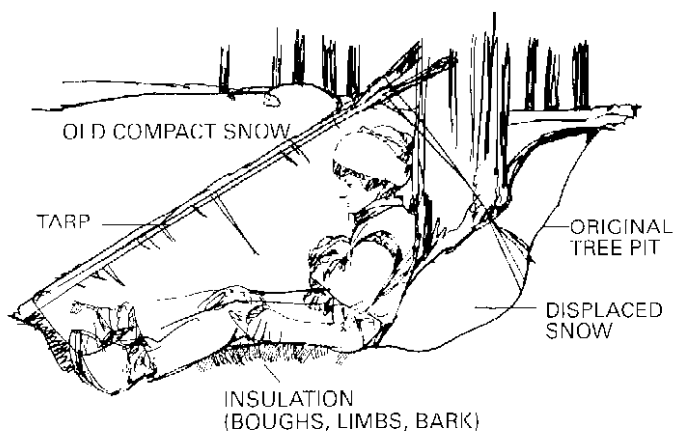

If using a fallen tree, rock, or root base, first build a framework by propping up branches 1 to 3 inches in diameter against the leeward (downwind) side. The walls should form an angle of 60 degrees with the ground to shed rain. Point the tips of the boughs downward for the same reason. Then weave smaller boughs between the larger ones and work large pieces of bark and boughs into this framework. If you were fortunate enough to have had the foresight to bring along a rescue blanket or large sheet of plastic, lay it over the framework.

If you are faced with a real survival situation, by all means, use live boughs. Your life far outweighs any ecological detriment caused by stripping off the boughs you need for shelter. If you lack a ground cloth you will need a substantial mat of boughs to insulate your body from the ground as well.

Thickly vegetated brush or small spruce trees can be bunched together and tied off at the top to fashion a fine shelter. By weaving other brush or boughs into any gaps, you can weatherproof your shelter to withstand even a wind-driven downpour.

A snapped-off sapling is an effective way to start building shelter. Pull over a sapling so that it breaks 4 to 5 feet above ground, but don't break it off com-

pletely. Let the top remain hinged to the trunk with the tip resting of the ground. You may need a large rock to hold it down. Then prop branches 1 to 3 inches in diameter on both sides similar to the log or rock shelter. Weave in smaller branches, cover it with material, and pile on boughs.

If nothing else is available to start your framework, you may need to lash three poles together, two 4 feet long and one 8 feet long for the ridge. Finish it off with weaving and cover it with material and boughs as explained previously.

Arctic-like regions require shelters that offer protection from the cold and the wind. Six different types are designed to serve different situations: a tree pit, snow pit, snow trench, snow cave, snow dome, and igloo. The first three are considerably easier to construct than the latter three. If possible, excavate the base of your winter shelter to bare mineral soil, because the earth emits some warmth (about 18 degrees) even in winter.

Many other shelters can be built. Use your ingenuity to construct one that fulfills your needs.

In any shelter—natural or constructed—be sure and insulate yourself from the ground. This is necessary under either hot or cold conditions. Stack branches, grass, dry leaves, extra clothing, whatever you have and can find that insulates you from the ground.

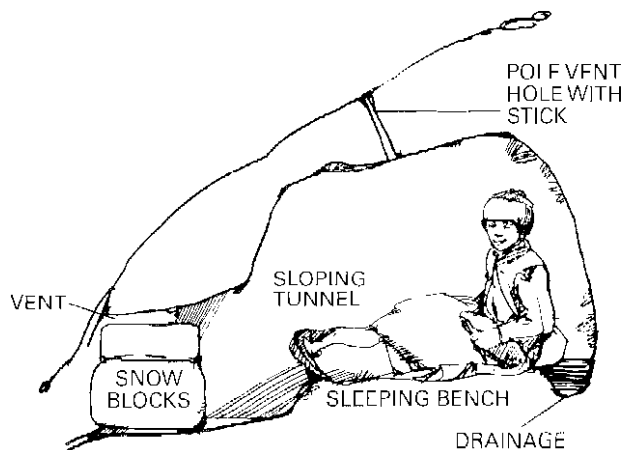

FIRES

Soon after shelter has been secured, the reassuring warmth of a fire will make you feel better emotionally as well as physically. Also, a fire is one of the best signaling devices you can use.

FIRE PREPARATION

Even in an emergency, take time to select the right place for your fire and prepare the ground before building it. A fire site out of the wind and protected from rain and snow should be found. Don't make a fire

under snow laden branches. If you do, before long a miniature snowslide from the tree will land right on your fire and you.

Your fire should be near your shelter. Scrape away the ground until you have removed all dry, burnable material so that your fire bed is on mineral earth.

Don't line your fire area with round stream-stones. They can heat up and explode like hand grenades. Do not prepare a huge fire. One large enough to keep you warm without roasting you is the idea. Keep the fire friendly.

After your fire site is prepared, find and haul your night's supply of fuel so that you will have it handy before dark. Protect it from the weather. With your fuel on hand, gather the driest tinder you can find—dry twigs, bark, moss, leaves. You can make tinder by whitening shavings from a dry stick.

Even in wet weather, dry tinder can be found if you know where to look. Often, dead branches will be dry. Look under trees, logs, and boulders. Push over standing deadwood. Once down, the deadwood will usually break easily, and dry wood can be found in the center.

Rotten stumps and logs are sources of tinder. You may even by lucky and find some pitchy wood. Finding materials for fire making is a great field exercise, and you will be surprised how ingenious you can be at finding dry materials even on the soggiest winter day.

Before starting your fire, you will have three stacks nearby. One will be tinder to start the fire and get the kindling burning. The second pile will be kindling, small branches, and larger twigs. The kindling will create the fire to burn the larger branches and logs. This larger material makes up your third pile.



FIRE STARTING

Ignite a small amount of tinder using one of the methods described below. As soon as the tinder bursts into flames, add more tinder to increase the flames. Do not add too much too soon or you will smother the fire. Add smaller pieces of kindling as the fire takes hold and grows. Keep adding kindling until your fire is big enough to burn larger fuel. As the fire grows, add fuel in a teepee shape, allowing plenty of air circulation to keep the fire going. Remember, the fire must have air. If necessary, blow on the base of the flame to increase its heat.

After the fire is safely ablaze, add larger pieces of fuel. Place them like the spokes of a wheel with the fire as a hub. As the wood is burned, push the fuel in the center. What you have is a friendly, controlled fire for warmth and for cooking.

FIRE-IGNITING TECHNIQUES

There are a number of ways to get that first tiny flame that you will build into a fire. Plan ahead so that you have the right materials in your emergency kit.

LIGHTERS

One of the most efficient fire igniters is a butane lighter. It will provide a hot flame long enough to start even slightly damp tinder.

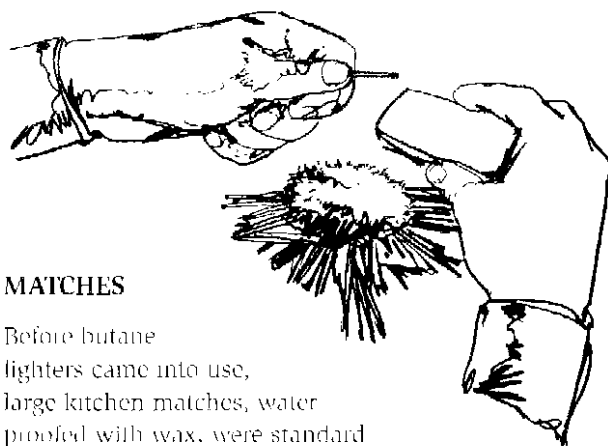

MATCHES

Before butane lighters came into use, large kitchen matches, water proofed with wax, were standard equipment, and many people still use them. They must be kept in a moisture-proof container.

FLINT AND STEEL

The flint and steel method of fire starting works well if the tinder is very dry and if the weather is dry. You can buy a flint and steel kit, along with instructions for its use.

METAL MATCH

Used with 0000 steel wool, the metal match is an efficient fire igniter. Take a small amount of steel wool and put tinder over it. Strike sparks with the metal match into the steel wool, gently blowing the sparks into the tinder.

OPTICAL

Concentration of the sun's rays through a magnifying lens onto dry tinder can start flame. To experiment, use a reading glass magnifier. Concentrate the sunlight so that a small, bright spot appears on a piece of paper. Hold the lens steady, and, if the sun is bright, you will soon see the paper begin to scorch and burn. Now, knowing that this can start a flame, try other magnifying lenses, such as flashlight lenses, eyeglasses, a camera lens, a rifle sight, whatever you think might work. While you may never need to use this method, it is always good to know . . . just in case.

CHEMICAL FIRE STARTERS

On the market today are a number of different materials that will catch fire easily and burn with intense heat. Some are in the form of tablets, others are stringlike, some can be molded between your fingers like putty. Just a touch of flame and they will burn long enough to get your fire started. CAUTION: Don't just buy these kinds of fire starters and put them in your emergency kit and forget about them. Try them first, after reading the instructions. The first time to try anything is *before* an emergency happens.

CANDLE

An old but still fine fire starter is a candle. It lights easily and will burn long enough to start your tinder. Waterproof matches and a short piece of candle, sealed in a waterproof container, is a combination to be found in the packs of many experienced outdoorsmen.

Because starting a fire, especially under wet conditions, is one of your most important survival skills, practice a variety of methods so that you can build a fire anywhere in the wilds, regardless of the weather.

FOOD

Surprisingly, food is a relatively unimportant survival consideration. A healthy person can live three weeks or more without eating, and because most lost persons are found within two or three days, there is little danger of starvation. However, in extremely cold conditions, when the body is burning lots of calories to keep itself warm, food becomes much more vital. If you are familiar with edible plants or knowledgeable in the ways of

wilderness fishing and trapping, you can forage for food if you desire, but don't waste energy you can't replenish. It may be better to wait quietly to be rescued than to exhaust yourself trying to eat off the land.

SURVIVAL FOOD

DON'T OVERLOOK HIGH-NUTRITION SNACK BARS WHEN PACKING YOUR SURVIVAL KIT. SEVERAL COMPANIES MAKE THESE SMALL—BUT NUTRITIOUS—BARS, WHICH CAN PROVIDE UP TO 100 PERCENT OF THE RECOMMENDED DAILY ALLOWANCES OF MOST VITAMINS AND MINERALS IN JUST ONE SERVING. PACKAGED AS TWO BARS IN AN AIR-TIGHT, WATERTIGHT FOIL POUCH, EACH SERVING PROVIDES A HIGH-CALORIE BOOST.

SNARES

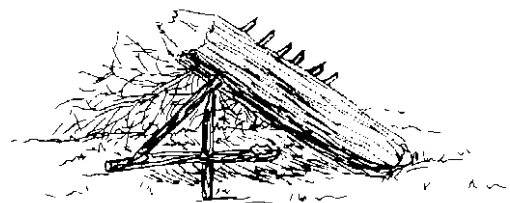
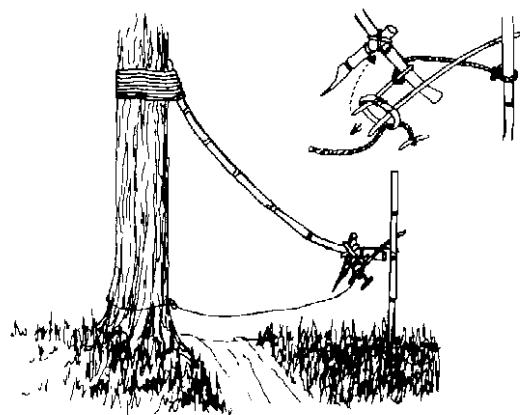
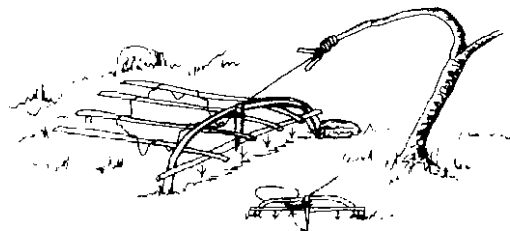

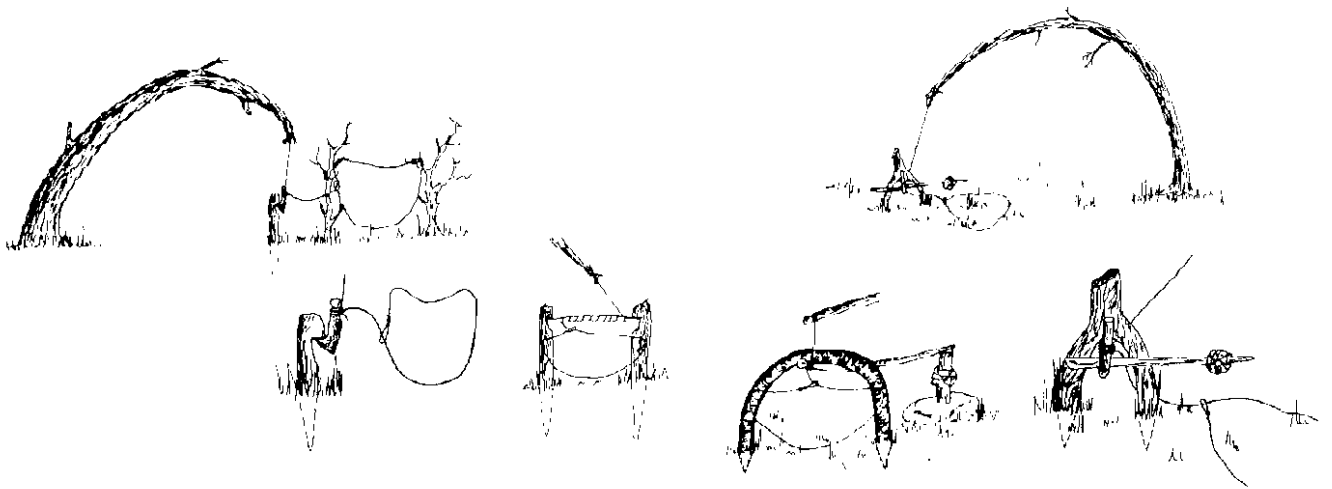

FISHING

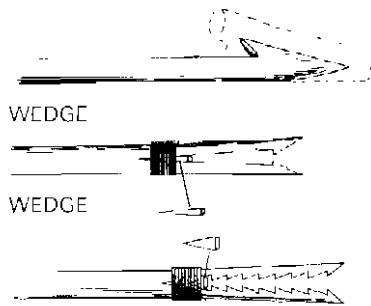

WEDGE
WEDGE

*to make a fish spear,
notch a barb in a long
stick and harden the
point in your campfire.*

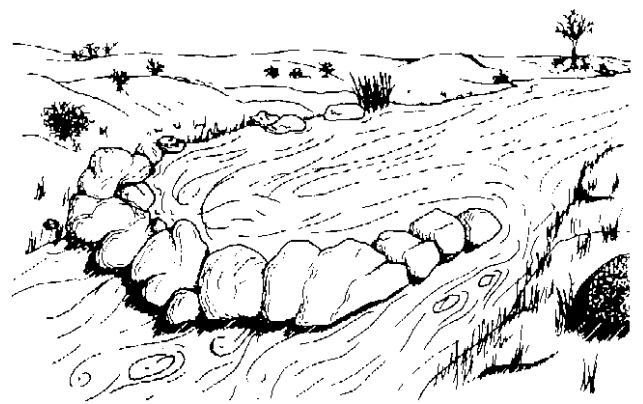

*A fish trap is formed by a low stone wall extending out
into the water*

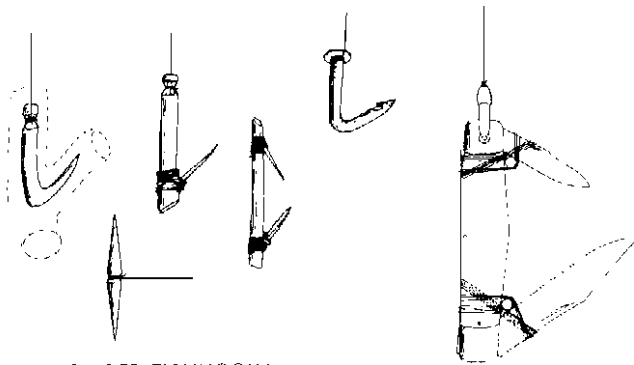

IMPROVISED FISHHOOKS

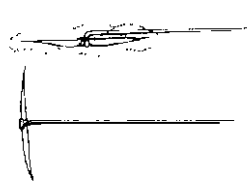

BAITED SKEWER

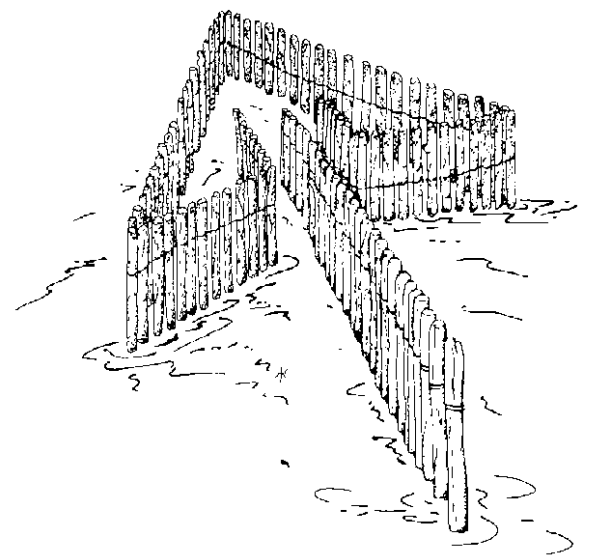
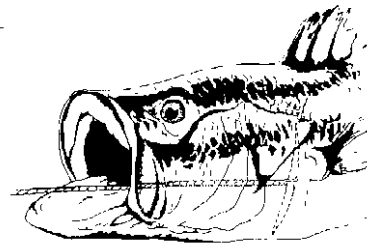

SURVIVAL KITS

FOUNTAIN PEN SURVIVAL KIT

Having slipped the pipeline of matches inside the pen barrel, also drop the following items inside:

- A small, magnetized needle
- Two tiny safety pins (the smallest are gold-colored)
- A small, high-quality modeling knife blade—the bent kind will stay sharper and stands less chance of snapping when you need it. If you cannot find one small enough, a pencil sharpener blade will suffice. The two small safety pins can be clipped crosswise to each other through the hole in the blade to make good “handlebars.”

Just a little experimenting will give you the right idea. Drop the mini-tube of salt inside, and tuck the birthday candle into the top of the barrel. Squeeze coils of thin tube wire next to the candle and matches pipeline in the mouth of the barrel. Now fold a piece of foil about 3 or 4 inches square around the matches, candles, and wire—your sun flasher for SOS.

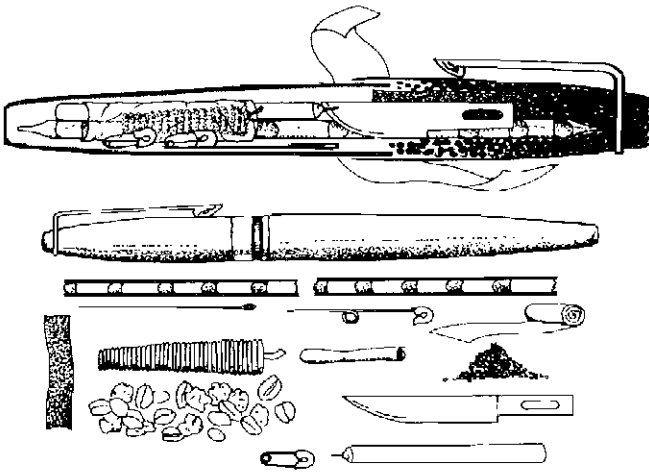

STANDARD SURVIVAL KIT

In addition to carrying a first-aid kit, you can further prepare yourself by taking a lightweight survival kit on all of your outings. Put the following items in a small plastic container, tape it shut, write the date on it, and open it only to replace perishable items or for a real emergency.

STANDARD SURVIVAL KIT

Rescue blanket
50 feet of nylon cord
Hard candy, chocolate, meal bar
Matches/metal match and 0000 steel wool
Candle/tire starters
Plastic whistle
Small glass signal mirror
Pen light with spare batteries
Small, sharp pocketknife
Metal cup or plastic water bottle
Water purification tablets
Clear plastic sheet or an emergency shelter

KEEPING WARM WITH A SPACE BLANKET

Although it looks like aluminum foil and weighs only 2 ounces, a space blanket can be one of the most valuable camping items in your pack. It measures 7 by 4 feet and can be folded neatly and tucked away for easy storage.

In cold weather, let the space blanket reflect the body's heat by placing it on top of your ground cushion or air mattress. Don't use it on top of a sleeping bag, though, because that causes condensation, which will get your sleeping bag wet!

Don't neglect to pack the space blanket on summer trips. The foil serves dual purposes as a lightweight emergency blanket or rain shelter.

SURVIVAL FISHING KIT

Anyone spending time in the outdoors should carry a survival kit that includes gear to catch fish for food. A simple kit should contain a few hooks of various sizes and styles, maybe a couple of trout flies (Woolly Worm patterns in size 6 or 8 are excellent choices), 10 feet of monofilament line of at least 10 pound test, and some rubber bands.

These items will fit nicely inside a 35mm film container, which can double as a float. Just wrap the rubber band around it to secure it to the fishing line.

SIGNALING

To attract the attention of rescuers, use signals that make you louder, larger, or more colorful than usual. Motion and colors that contrast sharply with their background are especially effective in attracting attention.

Audible signals. When you first become separated from your group, you might be able to attract their attention by blowing a whistle. Later, searchers may be close to you but unable to see you. Blow on a whistle occasionally in groups of three blasts to signal your location.

Passive visible signals. Many searches are conducted from aircraft, so large, angular ground signals that contrast in color with natural hues may catch the eye of an airborne rescuer. You can make the most common ground-to-air signal—a large X—by laying out brightly colored tents, tarps, or rescue blankets; by stamping down sand or snow with your boots; by pulling out clumps of turf; or by lining up branches and stones. A great advantage of ground signals is that they need no further effort once you've completed them, though as with other visual signals they are effective only when the sky is clear and light. Be sure to dismantle your ground signals after you've been rescued.

V

REQUIRE ASSISTANCE

Y

YES OR AFFIRMATIVE

↑

PROCEEDING IN THIS DIRECTION



X

REQUIRE MEDICAL ASSISTANCE

N

NO OR NEGATIVE

Active visible signals. Active visible signals don't work by themselves. They include mirrors, fires, and flares.

On a sunny day, the flash of a mirror can be seen by aircraft many miles away. If the mirror in your survival kit has an aiming device, use it. If not, hold the mirror

in one hand near your face, extend the other hand in front of you, and tilt the mirror until you can fill your empty palm with reflected light. Make a V with your illuminated fingers, then sight across the top of the mirror and through the V toward an aircraft and drop your empty hand out of the way. Repeat the procedure frequently to adjust your aim, and be especially certain to signal as a plane is flying toward you. A glass mirror reflects light better than one made of metal, but if you have no mirror, try using the lid of a tin can, a piece of foil, or any other shiny object.

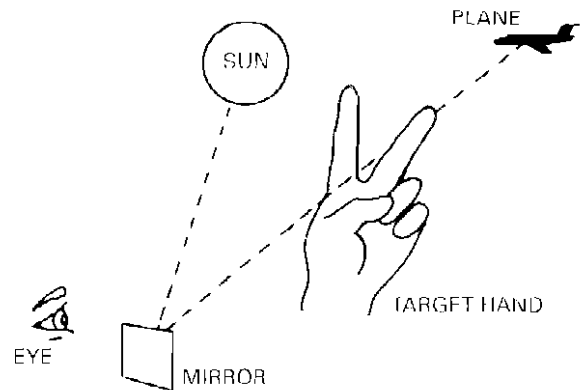

Smoke and flame are also good signals. Lay green leaves and evergreen boughs on a fire to create dense smoke that may attract the attention of pilots and fire wardens. Better yet, prepare second and third fires about 50 yards from the one that is burning, locating them so the three are the points of a large triangle. Keep a torch of easily flammable material near the blazing fire, and as soon as you hear an approaching aircraft, quickly ignite the additional fires. (A combination of any three signals is a universal sign of distress.)

Flares and smoke devices are useful for signaling, but since each can be used just once, activate them only when you've sighted a rescue craft. Follow the directions carefully.

HELP COMES IN THIRTS

THREE SIGNALS OF ANY TYPE IS THE UNIVERSAL SIGNAL FOR DISTRESS. IF YOU ARE LOST OR NEED ASSISTANCE IN THE OUTDOORS, JUST REMEMBER TO FIRE THREE SHOTS IN A ROW, SHOUT THREE TIMES,

OR WHISTLE THREE TIMES TO CALL FOR HELP. VISUAL SIGNS ALSO ARE SIGNALS, SUCH AS THREE LINES TRAMPLED IN A FIELD OR THREE BRIGHT FLAGS IN A ROW. REMEMBER, IF YOU NEED HELP, JUST KEEP TRYING UNTIL IT ARRIVES.

WATER

SAFE DRINKING WATER

“MAKING” WATER WITH A SOLAR STILL

Make a solar still in your backyard or on any convenient piece of land. It will give some results, though it is really meant for use in hot desert country where there is no water and you must manufacture your own supply.

The basic instructions are to dig a hole and cover this hole with a sheet of plastic. When the sun's rays pass through the plastic, they will be soaked up by the soil beneath, and will warm it. The earth's moisture under the plastic evaporates, and the water vapor this produces condenses on the underside of the cooler plastic and drips into a container placed at the bottom of the hole. Capillary action will cause more water to be drawn to the topsoil beneath the plastic to replace the moisture that has evaporated already. Because of this capillary action, a solar still can produce anywhere from 1 to 3 pints of drinkable water in the driest desert.

What's more, if a still begins to slow down in its production rate, you can move it to another “unmilked” area. Incidentally, a solar still will work at night too—but only half as well.

Find a low lying area in relation to the surrounding terrain. There shouldn't be anything nearby that will shade the still. Dig a basin-shaped hole about 3 feet in diameter and 2 feet deep, as shown in the diagram. Raise the edge of the hole so that it sticks up above its immediate surroundings. The purpose for this is to raise the plastic cover at the edges so that, if it rains, dirt won't be swept onto the sheet and foul the clean rain-water trapped there as a secondary drinking source.

Then position a bowl, can, or some other receptacle on the floor of your hole to catch the drips of condensation from the plastic sheet above. Before you place the plastic sheet across the hole, arrange a length of rubber or plastic tubing leading from the container up to, and over, the edge of the hole in the ground. This will let you drink from the container without having to take up the plastic sheet. In fact, you should try to leave the plastic in place at all times since every time you lift it, the condensation process has to start from scratch again.

Now stretch the plastic across the top of the hole. Anchor it in place with heavy rocks and seal any gaps with soil. Place a stone in the center so that the sheeting is pulled tight, yet at the same time it should not sag so sharply that it touches the sides of the hole or brushes against the container. Leave it for the sun to activate.

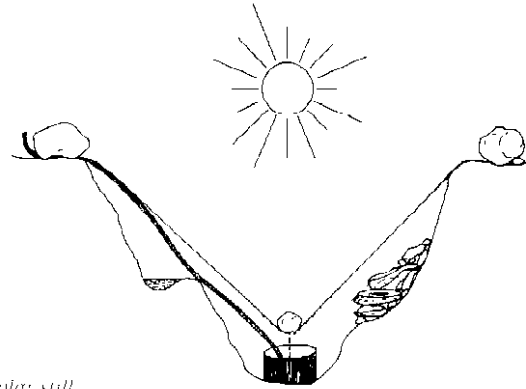

A solar still

PURIFYING WATER WITH A SOLAR STILL

A solar still can also be used to purify existing water such as urine, sea water, or almost any other kind of water that is undrinkable and dangerous (because it is so tempting to sip when you are going crazy with thirst).

How does the solar still purify polluted water? The still produces water vapor from the undrinkable liquid; the droplets formed on the underside of the plastic sheet are clean. By the same token, if you place pieces of fresh green plants in the hole, the moisture from these can also be evaporated and condensed on the plastic sheet.

Begin by digging a hole like the one described above. Once you have dug the hole, cut a trench in the side of this basin to hold the “contaminated” water such as urine or car radiator water (but it must not have anti-freeze in it). Carefully line the trench with plastic sheeting, and fill your trench with polluted water, such as dirty dishwater. Also, add newly chopped bits of greenery mentioned before, and lay them in the basin on the other side. Finish and use the still as described above.

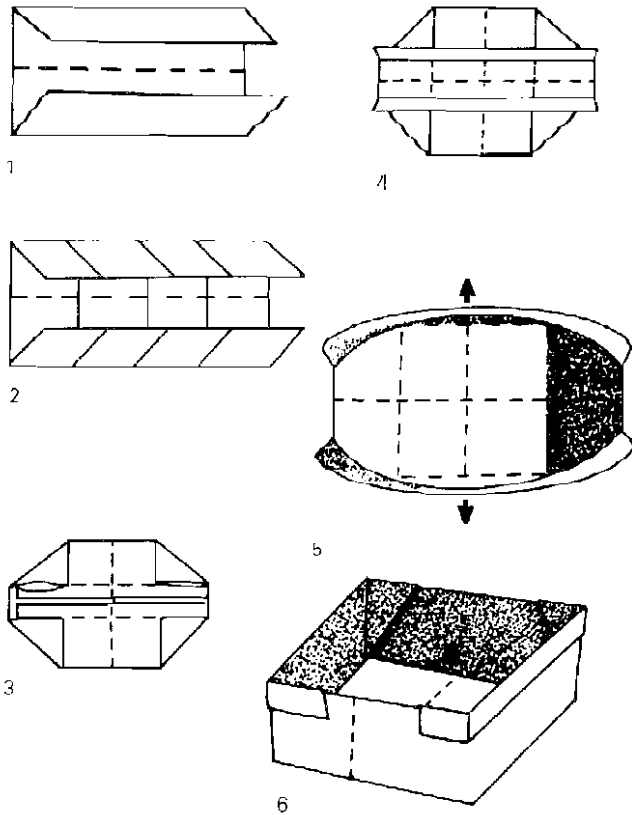

Paper pan for boiling water

PURIFYING WATER BY BOILING

The water you obtain from a solar still is fit to drink, but any water that already exists in natural surroundings, and that hasn't been produced by you, should be treated with suspicion. You need to purify it. The best way to do this is by boiling. Try it with rainwater. First, filter the water through a piece of cloth or a slice of bread. Then boil it. After 10 minutes, take the rainwater off the boil and drink it as it cools. That's right, it is insipid. However, if you try this again, but throw a few pieces of charcoal from the fire into the water at the beginning, you will notice a much sweeter taste. (You will need to filter the water again after boiling in this case.)

RESOURCES

- Backpacking*, by Randy Larson, Harvey, 1980.
- Handbook for Emergencies*, by Anthony Greenback, Doubleday, 1976.
- How to Survive*, by Brian Hildreth, Penguin, 1982.
- Outdoor Survival*, by Charles Platt Watts, 1976.
- Outdoor Survival Skills*, by Larry Olsen, Brigham Young University Press, 1967.
- Survival in the Wilds*, by Robert Schockley, Barnes, 1970.
- Surviving the Unexpected Wilderness Emergency*, rev. ed., by Gene Fear, Survival Education Association, 1975.
- You Can Survive*, by Howard Smith, McGraw, 1982.

BSA PUBLICATIONS

- Fieldbook*.
- Wilderness Survival* merit badge pamphlet.

SWIMMING CONTENTS

Background	59
Program Fields of Emphasis	59
State Swim Defense Plan	59
Equipment and Facilities	62
Officials	62
Race Events	63
Condensed Rules of Competitive Swimming	63
Strokes	65
Turns and Flips	69
Warm up and Conditioning Exercises	71
Swimming Practice	74
Coaching Swim Meets	74

SWIMMING

BACKGROUND



During the summer Olympic Games, Varsity Scouts witness the greatest swimmers in the world in head to head competition. Modern competitive swimming began in the late 19th century. Swimming became an Olympic event during the games played in 1896.

Varsity Scouts enjoy the excitement that competitive swimming provides. Competing against fellow team members and other teams in a swim meet provides an outlet for the Varsity Scout to measure his skills and abilities in a positive atmosphere.

This chapter introduces the team to competitive swimming. The chapter has sections covering everything from the starting blocks to the finish line, with slips and turns in the middle.

With the availability of swimming facilities in high schools, colleges, universities, and local swim clubs, the competitive swimming activity can be carried out during almost any time of the year.

And don't be surprised—a future Olympic swimmer just might be discovered while carrying out the Varsity swimming activity.

PROGRAM FIELDS OF EMPHASIS

The following ideas will help you plan a well-rounded program. Program managers carry out these ideas with help from a team committee member.

ADVANCEMENT

- Review each Varsity Scout's advancement status.
- Conduct a Swimming merit badge clinic.
- Monitor the team advancement chart regularly.

HIGH ADVENTURE/SPORTS

- Program manager outlines or updates the team's annual special high-adventure event (Philmont, Florida Sea Base, etc.).
- Conduct the Varsity swimming activity.

PERSONAL DEVELOPMENT

- Invite a qualified person to present a session on how to apply for a job.
- Visit an athletic complex (college or professional) and learn about occupations other than playing or coaching.

- Invite a qualified person to present a session explaining religious holy days or periods.
- Arrange to have meetings at a lap pool. Work on speed and distance.

SERVICE

- Conduct an awareness program on water conservation
- Visit a water treatment plant and learn how a team service project could be carried out.
- Carry out a service project identified in the visit to the water treatment plant.

SPECIAL PROGRAMS AND EVENTS

- Attend a high school, college, or university swim meet.
- Conduct a swim meet with other Varsity Scout teams.
- Visit a swimwear manufacturing facility.

SAFE SWIM DEFENSE PLAN

Varsity teams should begin the swimming activity by understanding the BSA Safe Swim Defense plan. These eight points are used regardless of the type of swimming activity the team chooses.

SAFE SWIM DEFENSE PLAN

All swimming activity in Scouting is conducted according to the Safe Swim Defense standards. The proven procedures included in this water safety plan have given Scouting what is believed to be the most exemplary water safety record of any youth organization. Previously known as the Eight Defense Plan, the concept was developed more than 60 years ago.

1. Qualified Supervision

All swimming activity must be supervised by a mature and conscientious adult age 21 or older who understands and knowingly accepts responsibility for the well-being and safety of youth members in his or her care, who is experienced in the water and confident of his or her ability to respond in the event of an emergency, and who is trained in and committed to compliance with the eight points of BSA Safe Swim Defense. (It is strongly recommended that all units have at least one adult or older youth member currently trained as a BSA Lifeguard to assist in the planning and conduct of all swimming activity.)

2. Physical Fitness

Require evidence of fitness for swimming activity with a complete health history from physician, parent, or legal guardian. The adult supervisor should adjust all supervision, discipline, and protection to anticipate any potential risks associated with individual health conditions. In the event of any significant health conditions, the unit leader should require proof of an examination by a physician.

Those with physical disabilities can enjoy and benefit from aquatics if the disabilities are known and necessary precautions are taken.

3. Safe Area

When swimming in areas not regularly maintained and used for swimming activity, have lifeguards and swimmers systematically examine the bottom of the swimming area to determine varying depths, deep holes, rocks, and stumps. **Mark off the area for three groups: not more than 3½ feet deep for non-swimmers; from shallow water to just over the head for beginners; deep water not more than 12 feet for swimmers.** A participant should not be permitted to swim in an area where he cannot readily recover and maintain his footing, or cannot maintain his position on the water, because of swimming ability or water flow. When setting up a safe swimming area in natural waters, use poles stuck in the bottom, or plastic bottles, balloons, or sticks attached to rock anchors with twine for boundary markers. Enclose nonswimmer and beginner areas with buoy lines (twine and floats) between markers. Mark the outer bounds of the swimmer area with floats. Be sure that clear water depth is at least 7 feet before allowing anyone to dive into the water. Diving is prohibited from any height more than 40 inches above the water surface; feet first entry is prohibited from more than 60 inches above the water. For any entry from more than 18 inches above the water surface, clear-water depth must be 10 to 12 feet. Only surface swimming is permitted in turbid water (less than 3 feet of clear visibility). Swimming is not permitted in water over 12 feet deep, in turbid water where poor visibility and depth would interfere with emergency recognition or prompt rescue, or in whitewater, unless all participants wear appropriate personal flotation devices and the supervisor determines that swimming with personal flotation equipment is safe under the circumstances.

4. Lifeguards on duty

Swim only where there are lifeguards on duty. For unit swims in areas where lifeguards are not provided by others, the supervisor should design-

ate two capable swimmers as lifeguards. Station them ashore equipped with a lifeline (a 100-foot length of ¼ inch nylon cord). In an emergency, one carries out the line; the other feeds it out from shore, then pulls in his partner and the person being helped. In addition, if a boat is available, have two people, preferably capable swimmers, take it out—one rowing and the other equipped with a 10-foot pole or extra oar. Provide one guard for every 10 people in the water, and adjust the number and positioning of guards as needed to protect the particular area and activity.

5. Lookout

Station a lookout on the shore where it is possible to see and hear everything in all areas. The lookout may be the adult in charge of the swim and may give the buddy signals.

6. Ability Groups

Divide into three ability groups: nonswimmers, beginners, and swimmers. Keep each group in its own area. *Nonswimmers* have not passed a swimming test. *Beginners* must pass this test: jump feet-first into water over the head in depth, level off, swim 25 feet on the surface. Stop, turn sharply, resume swimming as before and return to the starting place. *Swimmers* pass this test: jump feet-first into water over the head in depth. Level off and swim 75 yards in a *strong* manner using one or more of the following strokes: sidestroke, breaststroke, trudgen, or crawl; then swim 25 yards using an easy resting backstroke. The 100 yards must be completed in one swim without stops and must include at least one sharp turn. After completing the swim, rest by floating. **These classification tests should be renewed annually, preferably at the beginning of the season.**

7. Buddy System

Pair every youth with another in the same ability group. Buddies check in and out of the swimming area together. Emphasize that each buddy lifeguards his buddy. Check everyone in the water about every 10 minutes, or as needed to keep the buddies together. The adult in charge signals for a buddy check with a single blast of a whistle or ring of a bell and a call of "Buddies!" The adult counts slowly to 10 while buddies join and raise hands and remain still and silent. Guards check all areas, count the pairs, and compare the total with the number known to be in the water. Signal two blasts or bells to resume swimming. Signal three blasts or bells for checkout.

8. Discipline

Be sure everyone understands and agrees that **swimming is allowed only with proper supervision and use of the complete Safe Swim Defense**. The applicable rules should be presented and learned prior to the outing, and should be reviewed for all participants at the water's edge just before the swimming activity begins. Scouts should respect and follow all directions and rules of the adult supervisor. When people know the reason for rules and procedures, they are more likely to follow them. Be strict and fair, showing no favoritism.

SWIMMING SKILL

BSA Swimmer Test

Jump feetfirst into water over the head in depth, level off, and begin swimming. Swim 75 yards in a strong manner using one or more of the following strokes: sidestroke, breaststroke, trudgen, or crawl; then swim 25 yards using an easy, resting backstroke. The 100 yards must be completed in one swim without stops and must include at least one sharp turn. After completing the swim, rest by floating.

One of the most important elements of safe swimming is the ability to swim, and every First Class Scout has demonstrated that he is a strong, safe swimmer based on mastery of certain in-the-water skills. A strong swimmer can swim a reasonable distance on a confident, steady stroke, but a strong swimmer is not a safe swimmer until he can make a safe water entry, swim a restful stroke, and maintain himself in the water when hurt or exhausted.

The BSA Swimmers Test, required for First Class advancement, includes these in-the-water skills, and thereby demonstrates the minimum level of ability for safe deep water swimming. Consider the components of the test:

1. "Jump feet-first into water over the head in depth, level off, and begin swimming. . . ."

The swimmer must be able to make an abrupt entry into deep water and begin swimming without any aids. Walking in from shallow water, easing in from the edge or down a ladder, pushing off from side or bottom, and gaining forward momentum by diving do not satisfy this requirement.

2. ". . . Swim 75 yards in a strong manner using one or more of the following strokes: sidestroke, breaststroke, trudgen, or crawl; . . ."

The swimmer must be able to cover distance with a strong, confident stroke. The 75 yards must not be the outer limit of the swimmer's ability; completion of the distance should give evidence of sufficient stamina to avoid undue risks. Dog paddling and strokes repeatedly interrupted and restarted are not sufficient; underwater swimming is not permitted. The itemized strokes are inclusive. Any strong side or breaststroke, or any strong overarm stroke (including the back crawl), is acceptable.

3. ". . . swim 25 yards using an easy, resting backstroke. . . ."

The swimmer must indicate his ability to execute a restful, free-breathing backstroke that can be used to avoid exhaustion during swimming activity. This element of the test necessarily follows the more strenuous swimming activity to show that the swimmer is in fact able to use the backstroke as a relief from exertion. The change of stroke must be accomplished in deep water without any push off or other aid. Any variation of the elementary backstroke is acceptable. An overarm back crawl may suffice, if it clearly provides opportunity for the swimmer to rest and regain his wind.

4. ". . . The 100 yards must be completed in one swim without stops and must include at least one sharp turn. . . ."

The total distance is to be covered without rest stops. The sharp turn demonstrates the swimmer's ability to reverse direction in deep water without assistance or push-off from side or bottom.

5. ". . . After completing the swim, rest by floating."

This critically important component of the rest evaluates the swimmer's ability to maintain himself in the water indefinitely even though exhausted or otherwise unable to continue swimming. Treading water or swimming in place will further tire the swimmer and are therefore unacceptable. The duration of the float is not significant, except that it must be long enough for the test administrator to determine that the swimmer is in fact resting and could likely continue to do so for a prolonged period of time. Drownproofing may be sufficient if clearly restful, but is not preferred. If the test is completed except for the floating requirement, the swimmer may be retested on the floating only (after instruction) provided that the test administrator is confident that the swimmer can initiate the float when exhausted.

EQUIPMENT AND FACILITIES

POOL

Pools used for major competitive swim meets comply with the design standards set by the Federation de Natation Amateur (FINA). The term *Olympic pool* is normally used to define the size of the facility. Metric measurements are used when describing pool size.

The Olympic-size pool is 50 meters long, at least 21 meters wide, and 1.8 meters deep overall. There are eight lanes, each 2.5 meters wide, that run the length of the pool. Lanes are divided by ropes supported by colored floats. Lane markers are painted on the bottom of the pool.

Starting platforms are at one end of the pool at each lane. These platforms are square and rise above the water level 50 to 75 centimeters. The platform is sloped toward the water no more than 10 degrees. The platform is used for all events except the backstroke. For backstroke swimmers, hand grips are found below the starting platforms.

KEEPING TIME

Electronic timing devices are used in all major swim meets. These devices are located in each lane and are activated by an official called the starter. As each swimmer finishes an event, his time is recorded as he hits the touch pad. Touch pads are 2.4 meters wide and 90 centimeters deep. They are positioned 30 centimeters above and 60 centimeters below the water surface.

Electronic timing devices may malfunction or may not be used in some competitions. The timing is then performed by the *official timekeeper*, who uses a stopwatch to record each swimmer's time.

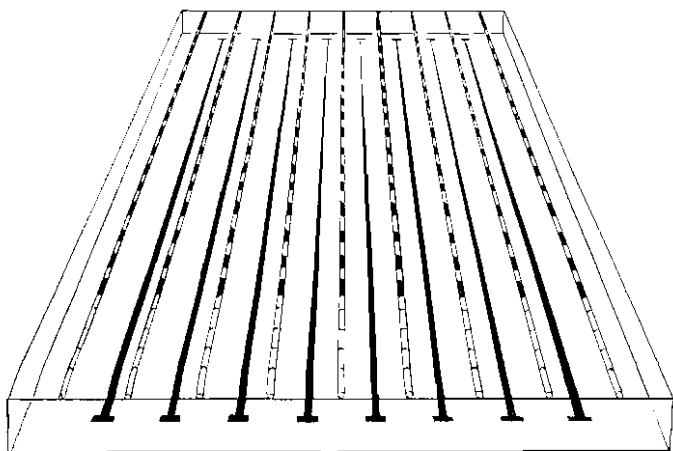

Regulation pool

SWIMWEAR

Swimmers wear a swimsuit and, if desired, goggles and a swim cap. Specific regulations are set by the meet officials on the type and style of swimwear permitted.

OFFICIALS

Swim meets are conducted under the direction of meet officials. These officials are: referee, starter, chief timekeeper, timekeepers, chief judge, finish judges, turn inspectors, stroke judges, course clerk, recorder, and announcer.

REFEREE

All swim meets are controlled by the *referee*. The referee is in charge of the overall meet to ensure that all rules are followed. Swimmers and other officials must adhere to the referee's directions and decisions. As in other sports, the referee has the final decision.

STARTER

The *starter* is in charge of the swimmers until the race begins. He makes sure that the race begins properly and may restart the race if necessary.

CHIEF TIMEKEEPER

The *chief timekeeper* assigns a timekeeper to each lane. He receives and examines the results of these timekeepers.

TIMEKEEPERS

The *timekeeper* in each lane records the time of each swimmer by using a stopwatch. Their results are given to the chief timekeeper.

CHIEF JUDGE

The *chief judge* assigns the finish judges, stroke judges, and turn inspectors to their lanes. He receives and examines their results.

FINISH JUDGES

The *finish judges* record the order of finish by the swimmers. They give their results to the chief judge.

TURN INSPECTORS

The *turn inspectors* monitor the swimmers to ensure that all turns and relay starts (takeoffs) are properly made. In multiple-lap races, these judges keep the swimmers informed of their status by displaying lap cards. Their results are given to the chief judge.

STROKE JUDGES

Stroke judges observe the swimmers to ensure that the proper stroke is being used. If an incorrect stroke is used, the referee is notified.

COURSE CLERK

The *course clerk* gathers and prepares the swimmers for the race.

RECORDER

The *recorder* maintains a record of all race results.

ANNOUNCER

The *announcer* communicates with the spectators. He announces the race, identifies the swimmers after they are in position, and reports the results of the race.

RACE EVENTS

Each swim meet has a series of events. The number of events staged will depend on the level of the competition. These events are modeled after those in Olympic competition. The metric system is used when describing these events.

OLYMPIC EVENTS	
STROKE	DISTANCE
Freestyle	100 meters
	200 meters
	400 meters
	800 meters
	1500 meters
Breaststroke	100 meters
	200 meters
Butterfly	100 meters
	200 meters
Backstroke	100 meters
	200 meters
Individual medley	200 meters
	400 meters
Freestyle relays	4 × 100 meters
	4 × 200 meters
Medley relay	4 × 100 meters

CONDENSED RULES OF COMPETITIVE SWIMMING

Competitive swimming has rules that apply in all meets. There are additional rules for each event conducted at the meet.

STANDARD RULES FOR ALL MEETS

SWIMMER

Each swimmer must remain in his assigned lane at the start of the race, during the swim, and at the finish of the race. He must follow the rules relating to the specific stroke or for the event in which he is swimming.

DISQUALIFICATIONS

A swimmer can be disqualified for

- general misconduct
- interfering with another swimmer
- obstructing another swimmer
- walking (not standing) on the pool bottom
- taking a step from the pool bottom when in a turn
- failing to touch the side of the pool during a turn

STARTING POSITION

Swimmers are assigned their starting lane positions based on their event-qualifying time. The fastest swimmer is placed in the center lane. In descending times, swimmers are placed to the left and to the right of the fastest swimmer. The slowest swimmers are always on the outside lanes.

START OF THE RACE

For all races except the backstroke, swimmers begin from the starting platform. The swimmer steps onto the platform and waits for directions from the starter. When the starter commands "Take your mark," the swimmer moves to the front (waterside) of the platform and gets into starting position. When all swimmers are in position, starter issues the start signal by yelling "Go," by blowing a whistle, or by firing a shot. The starting position for the backstroke is in the water, facing the starting line. The swimmer's feet must be under the water. On the command "Take your mark," the swimmer grasps the hand grip.

FALSE START

The starter's responsibility includes ensuring that no swimmer leaves the starting position too soon. If this occurs, the starter recalls all swimmers to the starting platform. After two false starts are committed, the starter warns that the next swimmer causing a false start will be disqualified.

ADDITIONAL EVENT RULES

BREASTSTROKE

1. The swimmer's body must remain on the breast with the shoulders parallel to the water surface.
2. The swimmer's hands must be together when pushed forward from the breast and remain under or on the surface of the water when brought back. Both arms must be moved at the same time.
3. All leg movements must be simultaneous. During the leg kick, the feet must be turned out in a backward movement. The dolphin kick (described in the section on "Strokes") is not allowed.
4. The swimmer's head must break the surface of the water throughout the race, except at the start or when making a turn.
5. When making a turn, the swimmer must touch the wall with both hands at the same time, although they may be at uneven levels. The swimmer may also take a one arm stroke and a one-arm kick while making a turn.
6. At the finish, the swimmer must touch the wall with both hands, which must be at the same level. This touch can be at, above, or below the water level.

BUTTERFLY

1. The swimmer's body must remain on the breast with the shoulders parallel to the water surface.
2. The arms are extended forward of the shoulders at the same time. The arms are pulled backward under the water at the same time.
3. The feet and leg movement must be simultaneous. The dolphin kick is permitted.
4. When making a turn *and* at the finish, the swimmer must touch the wall with both hands at the same time and at the same level.
5. The swimmer may, at the start and at turns, use a one-arm pull and one or more leg kicks under the water, which must bring the swimmer to the surface of the water.

BACKSTROKE

1. The swimmer must swim on the back during the entire race.
2. On turns, the swimmer must touch the wall with at least one hand. Somersault turns may be used.
3. After turning, the swimmer must return to the back while the feet are in contact with the wall.
4. The swimmer must be on the back when touching the finish line (wall).

FREESTYLE

1. In individual freestyle events, swimmers may use their choice of stroke.
2. When in medley relay or individual medley events, *freestyle* is defined as any stroke other than butterfly, breaststroke, or backstroke.
3. During turns and at the finish, the swimmer is permitted to use any part of the body to make the mandatory touch of the wall.

FRONT CRAWL

The front crawl is the most favored stroke used when swimming the freestyle. The swimmer's stomach is on the water surface. Each arm (alternately) is brought over, forward into the water, and returned under the water. The swimmer turns his head to the side for breathing as one of the arms is brought out of the water.

MEDLEY EVENTS

In medley events, swimmers swim equal distances in each of the four strokes. When swimming an individual medley, the stroke sequence is butterfly, backstroke, breaststroke, and freestyle. In medley relays, the sequence is backstroke, breaststroke, butterfly, and freestyle. Each swimmer on the medley team swims one stroke for the prescribed distance.

RELAY EVENTS

In relay events, the second (or next) swimmer must remain on the starting platform until the current swimmer finishes the distance *and* touches the wall of the pool. If the second (or next) swimmer dives too soon, he must return to the starting position (not on the platform) before swimming the assigned length of the relay. Failure to do so will disqualify the team.

Only the swimmer designated to swim a particular length may be in the water. If another team member enters the water before the finish of the race, the team will be disqualified.

STROKES

You are already a good swimmer, as shown by your completion of Second Class and First Class swimming requirements. To earn the Swimming merit badge you must further demonstrate your swimming strength and stroke proficiency by swimming 150 yards using a combination of five strokes. You must swim continuously in a strong manner for the entire distance, showing good form on the front crawl or trudgen for 25 yards, the back crawl for 25 yards, the sidestroke for 25 yards, the breaststroke for 25 yards, and the elementary backstroke for 50 yards.

"Good form" requires that each stroke be performed consistent with the proper technique. For example, the breaststroke is a restful stroke that includes a long, prone glide between strokes. If your breaststroke is a vigorous, bobbing stroke as used in competition, it is not satisfactory for this requirement. Doing the backstroke using a frog kick rather than the prescribed whip kick also is similarly unacceptable for this requirement.

You also are required to swim the specified strokes in a "strong manner." This means no rest stops and no gasping, panting completions. The stroke sequence begins with the more strenuous strokes and moves progressively through the more restful strokes, concluding with the most restful. The stroke sequence should be followed as presented in the requirement. If you complete the swim "in a strong manner" in the specified sequence, then you should be rested and able to continue well beyond the 150-yard requirement.

On the following pages the required strokes are illustrated and explained as you should swim them.

FRONT CRAWL

The *front crawl* has three parts: the flutter kick, the rotating arm stroke, and rhythmic breathing. It is the fastest and one of the most graceful of all swimming strokes.

The flutter kick relies on relaxed ankles and the use of the entire leg. The movement begins at the hips and flows to the feet. As one foot moves downward, the other comes up in a beating or fluttering rhythm. The kick should be smooth and steady, of even range (8 to 12 inches), and just below the surface of the water. You can practice the kick by holding the edge of the pool or by supporting yourself on a buoyant kickboard.

Practice the arm stroke in waist-deep water. Bend forward so that the top of your body is in a swimming position. Extend your right arm and swing it down to your hip, and then raise that elbow to extend your arm forward again. Alternate with your left arm. Keep your fingers together and your hands cupped.

Push off into a glide. Use the flutter kick and arm stroke together to move through the water. Remember to exhale through your mouth and nose while your face is in the water. To inhale, roll your head to one side as the arm on that side is pulling to your hip and the elbow is lifting out of the water. Inhale through your mouth, then turn your face back into the water as your arm is recovering to the extended position in front of you.

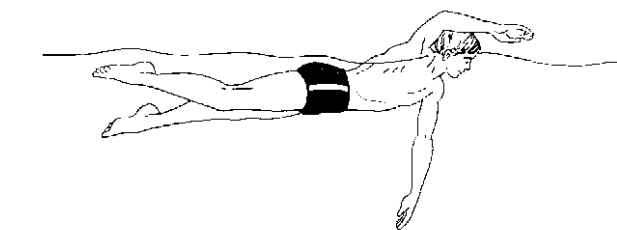
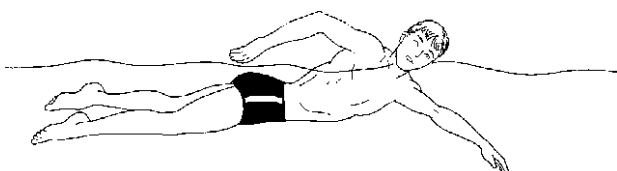
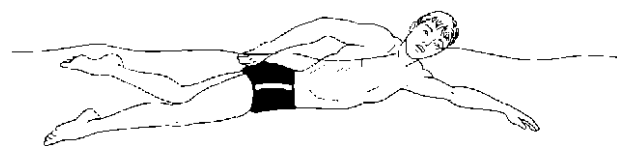
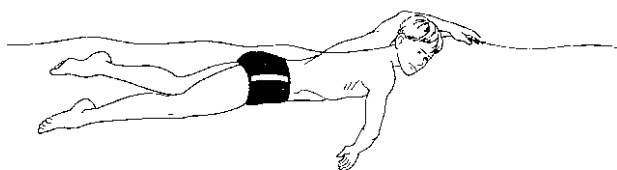
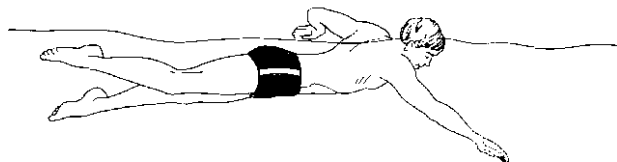

Front crawl

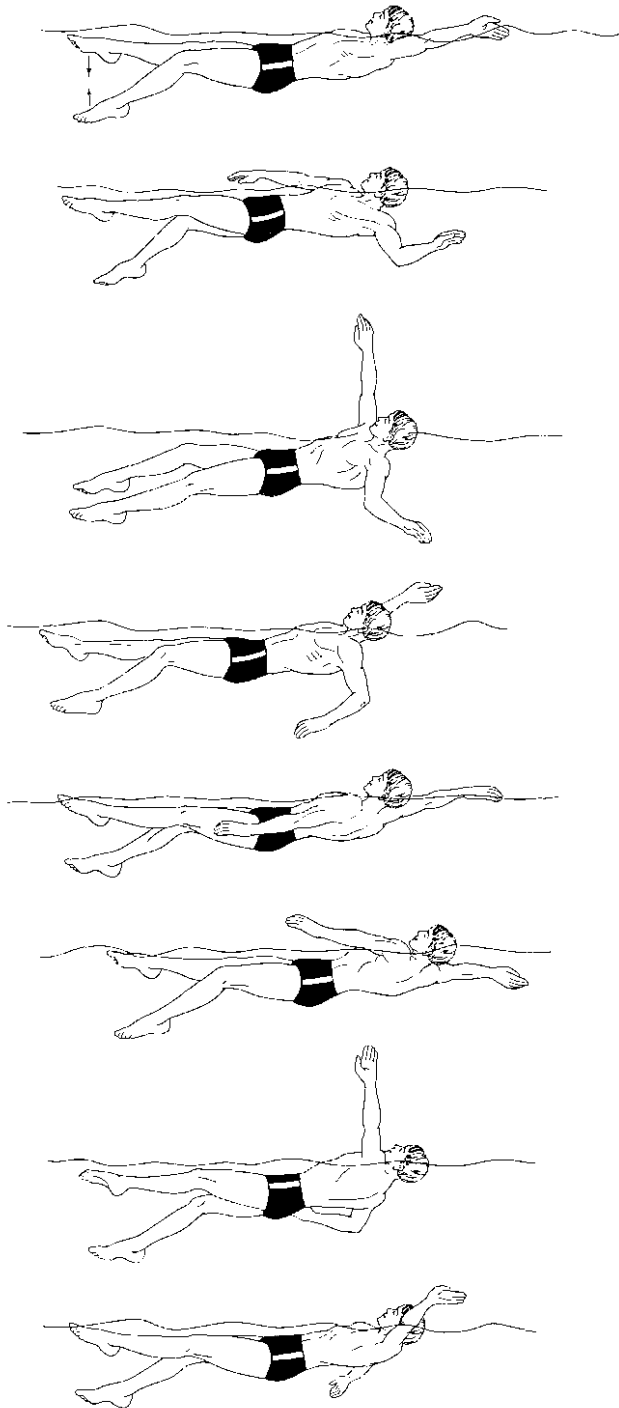

Back crawl

BACK CRAWL

The *back crawl*, or racing backstroke, has the advantages of speed and a faceup position. The leg motion is the flutter kick, and the arms work in a continuous alternating motion with one pulling as the other recovers. Bring your arm out of the water at your hip and through the air to slice back into the water at a point beyond your head. Keep your fingers together and your hands cupped.

SIDESTROKE

The *sidestroke* is another good long-distance stroke with a long, restful glide. It also introduces the scissors kick, which is used in swimming rescues.

Start in the extended glide position on your side with one ear in the water, your nose and mouth turned to the shoulder out of the water, and your eyes looking toward your feet. Begin moving the leading arm into a catch motion, then start the trailing arm and leg action. The leading arm pulls as the trailing arm slices through the water toward the upper chest; the legs bend as the trailing arm moves forward. Pull the leading arm to a point just below your chest. As your arms begin to change directions, extend your top leg forward and your lower leg back. Without stopping, continue to move your arms and snap your feet together in a scissoring motion. The stroke is complete when you arrive back at the glide position. Hold the glide position for three or four counts and repeat the stroke.

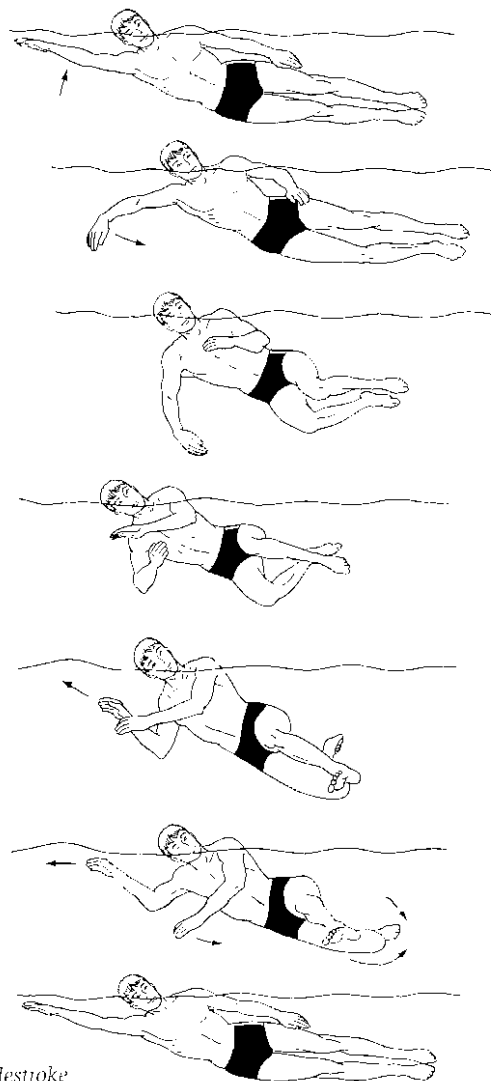

Sidestroke

TRUDGEN

Experienced swimmers frequently prefer the *trudgen* as a strong, energy-conserving, all-purpose stroke. It combines the arm movements and breathing of the front crawl stroke with the hips turning up on the breathing side just as the arm on that side completes its pull. The legs trail in the extended position as the other arm pull is performed. This interesting stroke was named for Englishman John Trudgen, who introduced the stroke in competition in 1868.

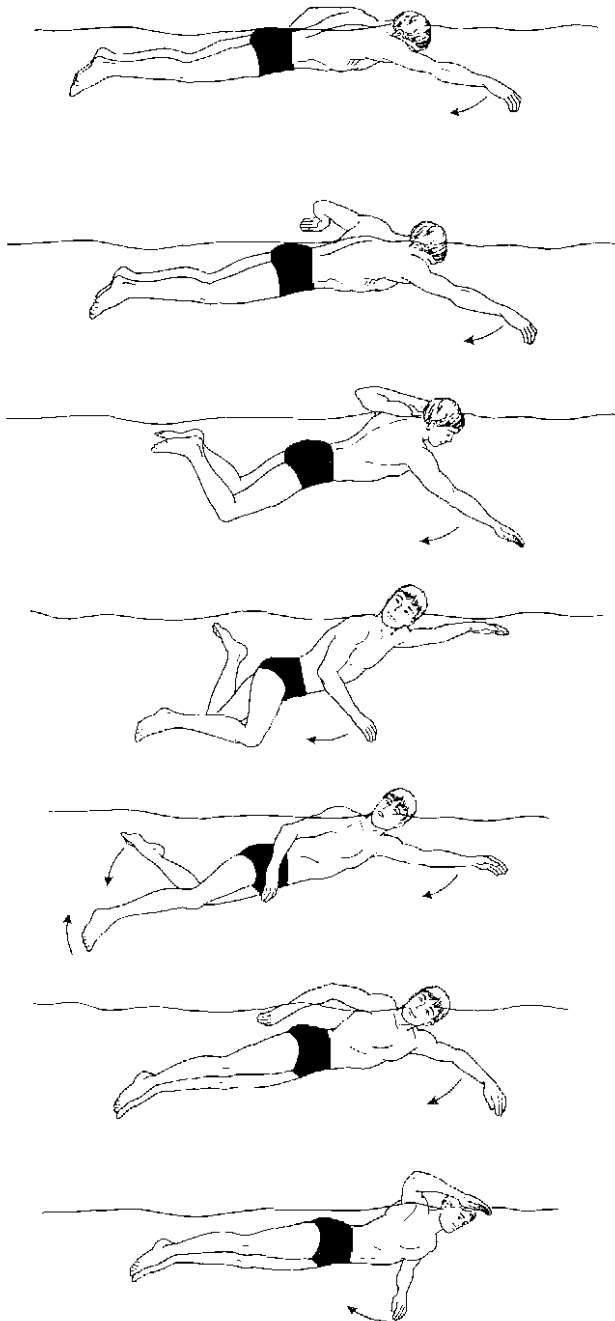

Trudgen

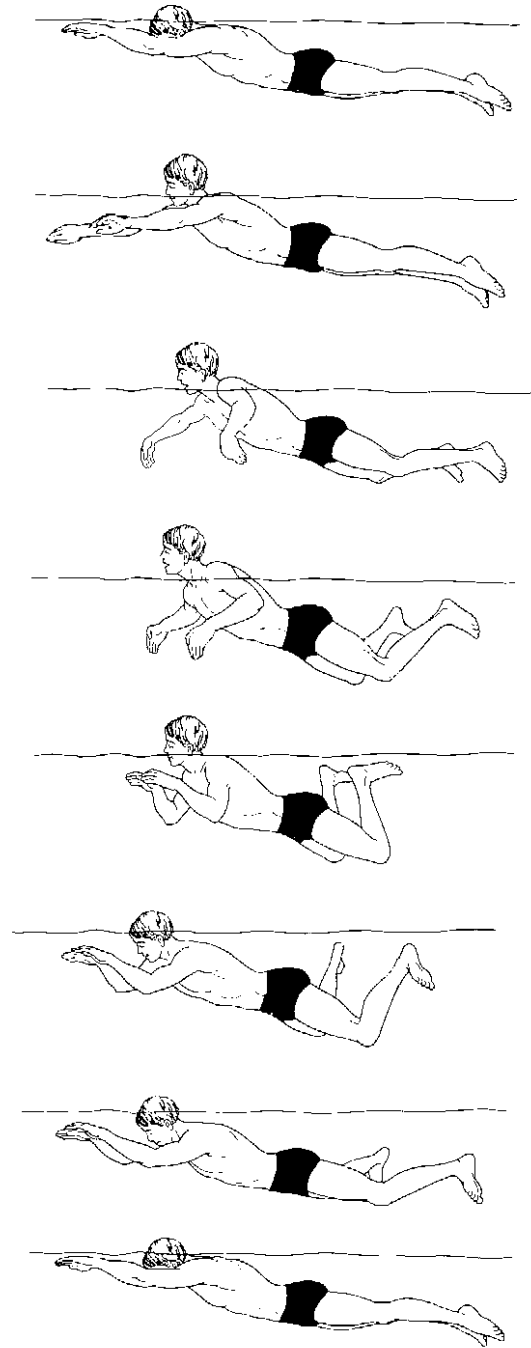

Breaststroke

BREASTSTROKE

This is one of the oldest strokes used in Scouting, and variations range from a restful distance stroke to a competitive racing stroke. With an extended glide as is taught in Scouting, the *breaststroke* is a powerful, long-distance stroke that conserves energy and has applications in lifesaving. The stroke uses a whip kick and shallow arm pull.

Start in the prone glide position with your face in the water. As you drop and pull your hands, lift your face out of the water to breathe and draw your feet toward your hips. When your arms are at shoulder level, your legs should be under your hips with your feet drawn up. Inhale and have your face ready to go back into the water. Rotate your hands until they meet under your chin and thrust them through the water to the extended position. Push your legs out and back in a circular motion as your face returns to the water, ankles touch, and legs extend. Hold the glide for a count of three or four while exhaling into the water. Then begin the stroke again.

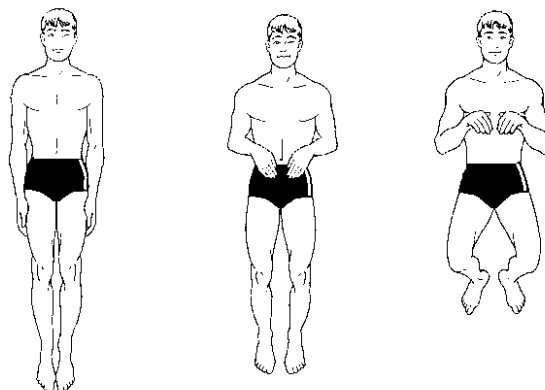

ELEMENTARY BACKSTROKE

The *elementary backstroke* is the resting stroke for the last 25 yards of your test, and you should be less exhausted at the end of the distance compared with when you began the stroke. Use this stroke for long-distance swimming or for when you are tiring and want to rest while continuing to make progress.

Start on your back in the glide position, legs extended, arms at your sides, hands at your thighs, and toes pointed. Move your hands up while you begin to drop your heels. As you extend your hands outward, turn your toes outward. Now complete the power part of the stroke by sweeping your hands down toward your feet and whipping your feet back together in circular motion. To avoid getting water in your mouth and nose, drop your chin to your chest as your arms push toward your feet.

Start on your back in the glide position, legs extended, arms at your sides, hands at your thighs, and toes pointed. Move your hands up while you begin to drop your heels. As you extend your hands outward, turn your toes outward. Now complete the power part of the stroke by sweeping your hands down toward your feet and whipping your feet back together in circular motion. To avoid getting water in your mouth and nose, drop your chin to your chest as your arms push toward your feet.

Make your movements continuous, resting only at the end of the stroke to permit a long glide. As you finish your glide, repeat the process. Keep your head in line with your body. Don't be in a hurry. Remember, this is a resting stroke, so be sure to relax and glide for three or four counts.

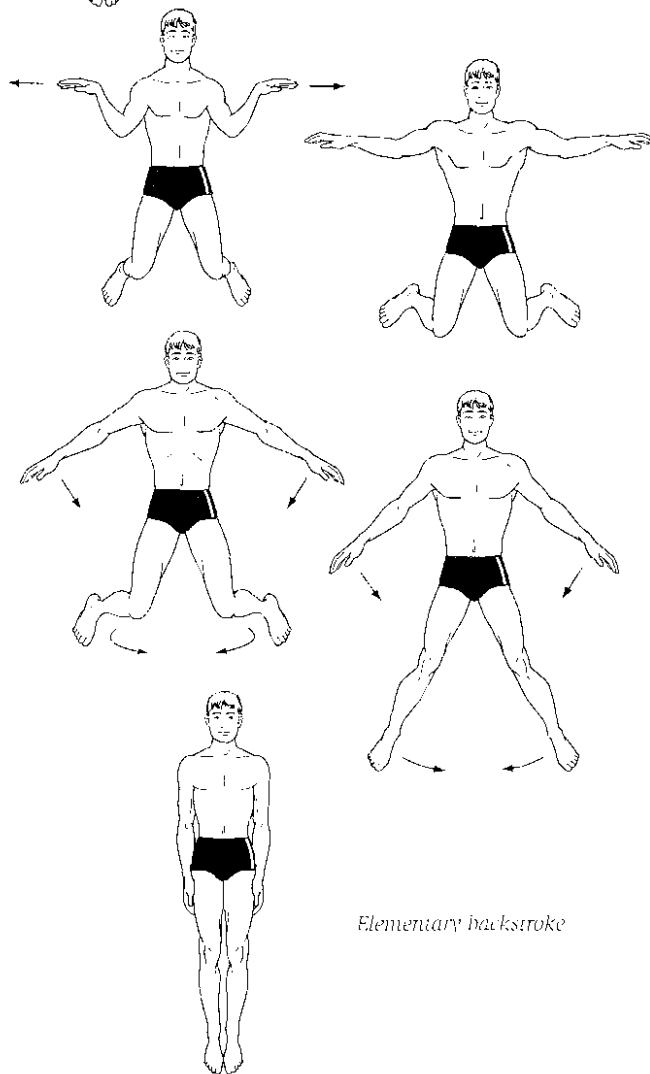

Elementary backstroke

URNS AND FLIPS

Competitive swim meets are won by swimming faster than the other team or individual. Making turns at either end of the pool is an important part of competitive swimming. Swimmers should practice turns on their own every chance they get.

Swimmers must keep their eyes open. This is to enable them to see the wall when approaching a turn. the swimmer should not breathe during the final one or two strokes just before a turn.

FLIP-STYLE, TURN-CRAWL STROKE

As the swimmer approaches the wall, one hand is by the side as the other hand propels the body into the turn. As the arm stroke is completed, the swimmer does a dolphin kick and begins a somersault. When the somersault (flip) is completed, both feet are planted on the wall. The body should be facing to the side. The hands are pushed down to bring the head near the water surface. The arms then begin extending forward. This places the swimmer in a somewhat crouched position, knees bent and both feet on the wall. The swimmer then pushes off the wall with both legs, rotating the body to a prone position. As the legs extend, the swimmer glides until momentum begins to fade. The swimmer then makes one or two kicks, and begins the arm stroke.

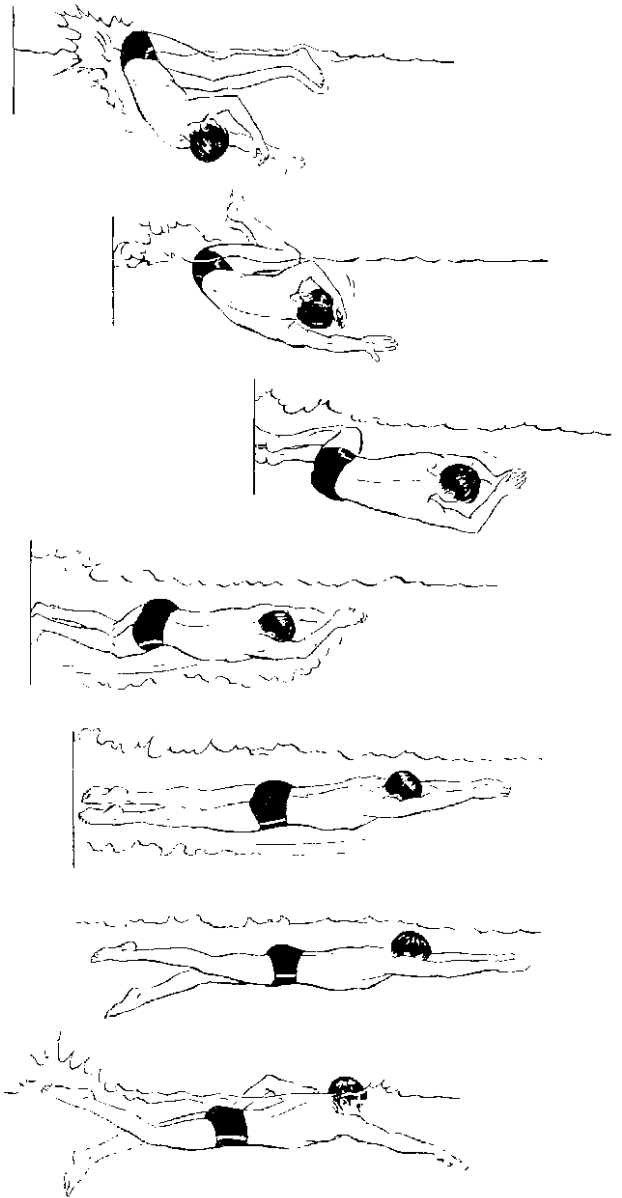
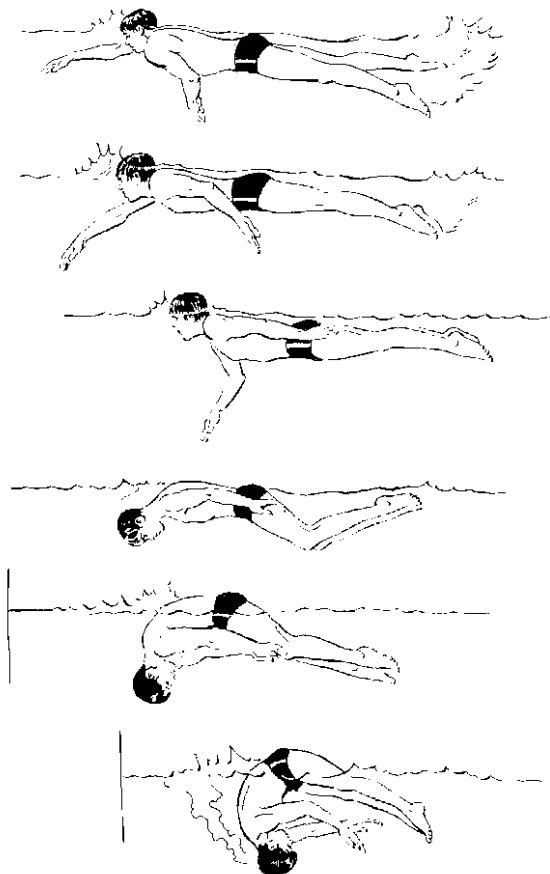

ROLL TURN-BACK CRAWL

As the swimmer approaches the wall, he reaches behind the head while rotating to a prone position. If touching the wall with the right hand, the body is rotated to the left. After the wall is touched, the swimmer completes the rotation to a prone position and somersaults into the wall. While doing the somersault, the hands are brought together, arms then extended, as the feet touch the wall. The body is crouched with knees bent, and facing upward. The swimmer then pushes off the wall with both legs in a streamlined glide position. The swimmer stays in the glide position until momentum fades. The swimmer then begins to kick and uses the first arm stroke to bring the body upward to the surface.

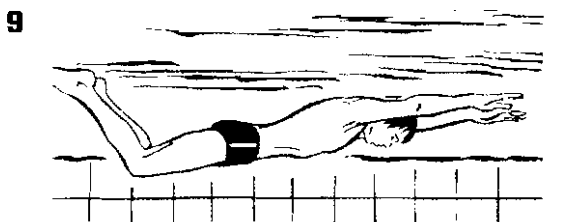
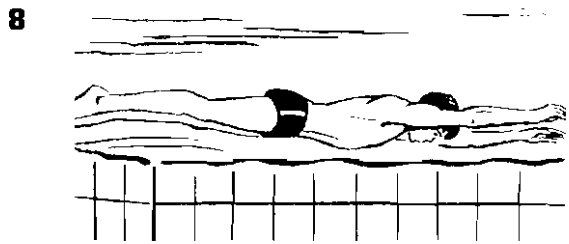
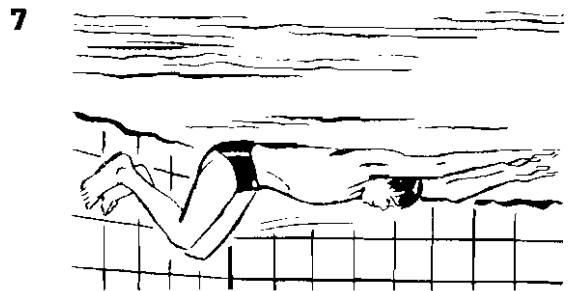
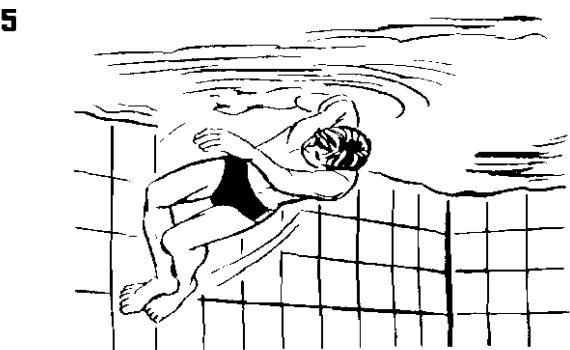
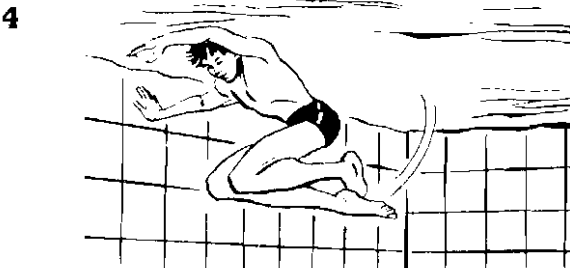
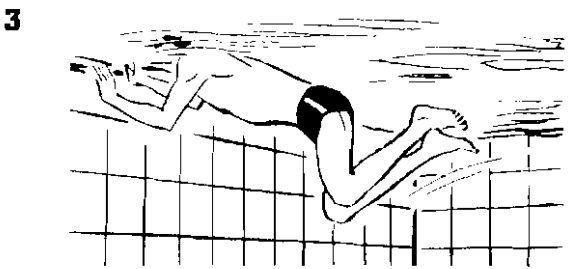
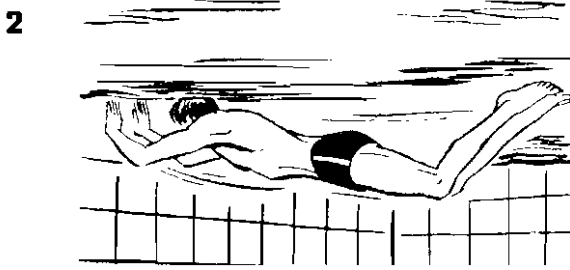
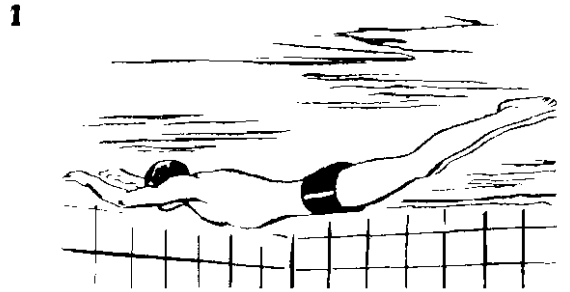

BUTTERFLY AND BREASTSTROKE TURN

The swimmer reaches for the wall with both hands. If the pool has a gutter, the swimmer grabs it. At the same time, the knees begin bending and rotating the body to the left (right). The legs are tucked tightly and pulled into the wall with the right (left) hand. The left (right) hand is removed from the wall and the left (right) elbow is pulled into the ribs. The feet pass under the body; the right (left) hand releases the gutter. The body should now be facing to the side, in a crouched position, knees

bent, both feet on the wall, with the arms extended forward. The swimmer then pushes off the wall with both legs, rotating the body to the prone glide position. The swimmer stays in the glide position until momentum fades. The swimmer then executes one or two kicks and begins the arm stroke.

This turn is carried out the same way for the butterfly and breaststroke except for the body angle during push-off and the shoulder rotation. When in breaststroke competition, the push-off angle should be downward. Breaststroke swimmers are permitted only one arm stroke and one leg kick under water. For butterfly competition, the swimmer must place both hands on the wall at the same level simultaneously. The swimmer must therefore delay their shoulder rotation until after both hands touch.

WARM-UP AND CONDITIONING EXERCISES

There are very few drills for exercising or conditioning that can be carried out unless the Varsity team member is in the water. This is different than in other sports. The muscles and body endurance are built by swimming the various strokes. Exercise to build body bulk should be avoided, since body bulk will cause more drag in the water, thus slowing the swimmer.

WARM-UPS

The swimmer warms up prior to meets and before carrying out practice or conditioning drills. Warm-ups consist of stretching and flexibility exercises. The swimmer should develop exercises that he likes in addition to these listed.

Move your right arm forward in a circular motion as if you were doing the crawl stroke. Repeat the movement using your left arm.

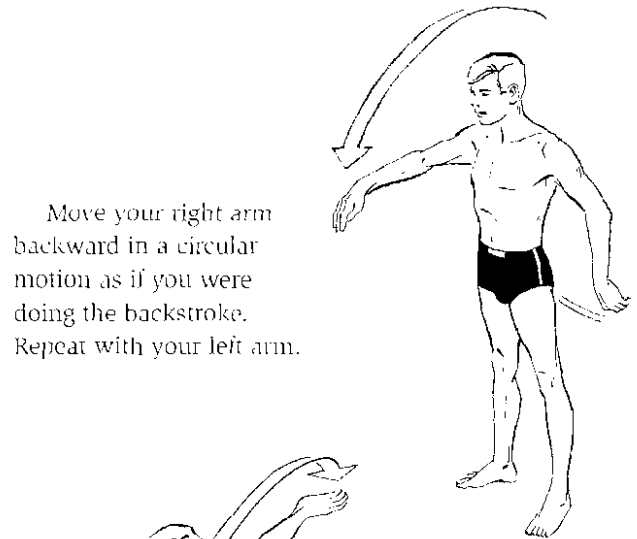

Move your right arm backward in a circular motion as if you were doing the backstroke. Repeat with your left arm.

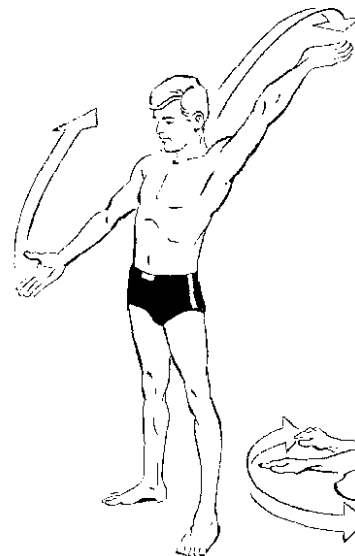

Hold both arms parallel to the floor. Swing both arms from side to side, crossing them in the front of your body.

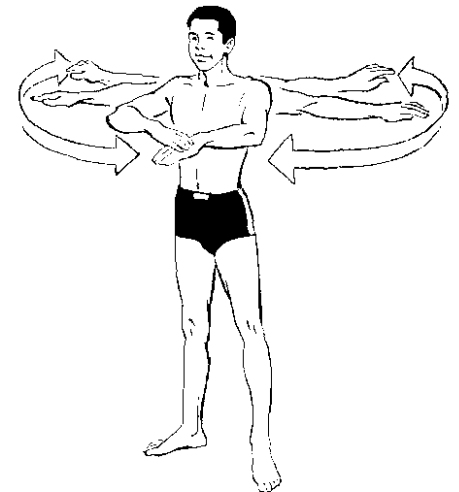

Then swing and stretch them to the back of your body as far as possible.

Grasp both hands together and extend them upward. Push your hands to the left, and then to the right as far as possible.

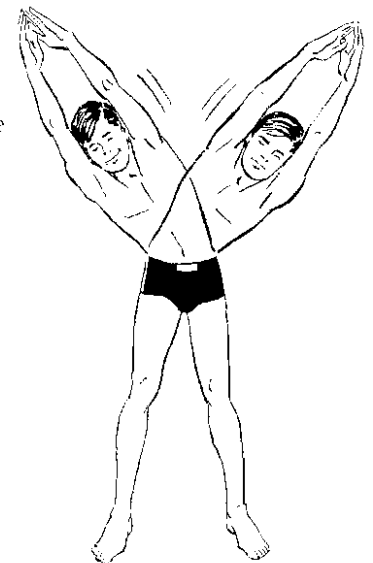

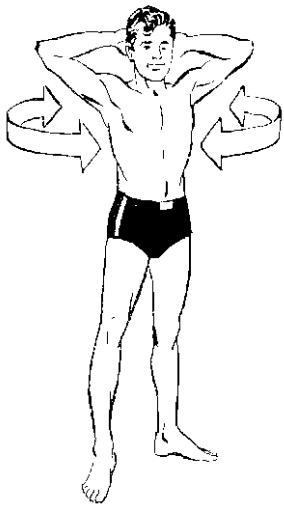

Grasp your hands together and place them behind your head with your elbows bent. Move your arms to the right and then to the left, stretching as far as possible.

Spread your feet. Bend forward and down as far as possible toward the toes. Return. Bend forward and down as far left as possible with both hands. Return. Repeat to the right side as far as possible. Return to an upright position.

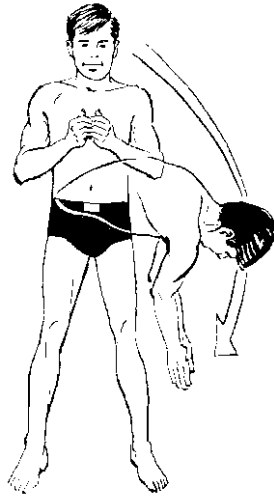

While standing on your right foot, bend your left knee and grab your left foot. While pulling on your left foot, bend forward slowly to stretch your left leg. Repeat for your right leg. This exercise must be done slowly to avoid muscle pull. When first doing this exercise it may be necessary to maintain balance with your free hand.

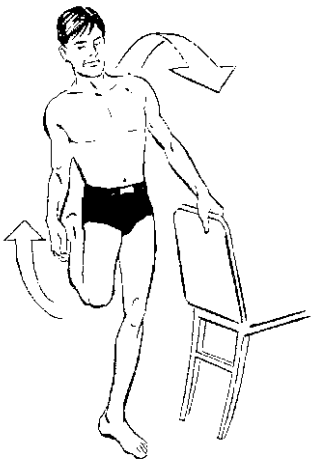

While standing about 3 feet from a wall, reach forward and place both hands on the wall. Your extended arms should be at shoulder level. Keep your body straight. As your elbows are slowly bent lean into the wall while keeping both heels on the floor. This causes your calf muscles to stretch. Do this exercise slowly to avoid muscle pull.

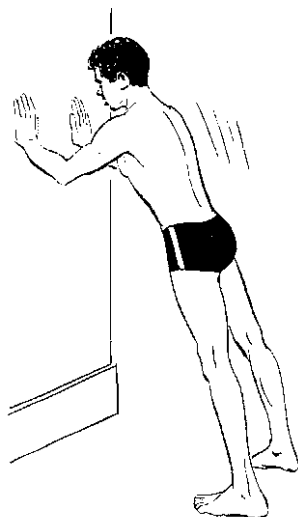

While standing about 3 feet from a wall, reach forward and place your hands on the wall with your arms at shoulder height. Keep your arms straight and bend forward. Drop your head lower than your arms. This causes your neck muscles to stretch. Do this exercise only two or three times. To avoid pulling your neck muscles, hold your head down no longer than 10 seconds.

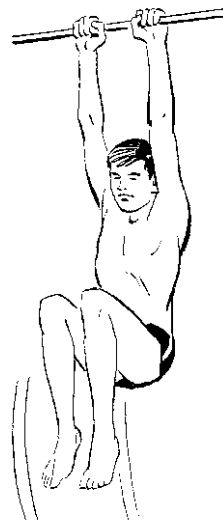
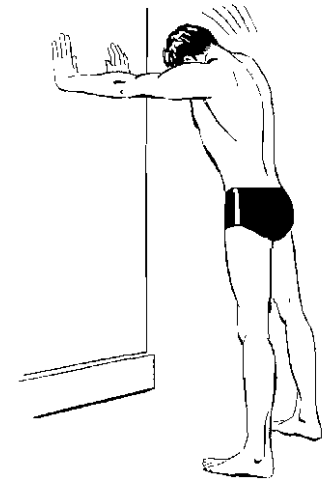

Hang from a chinning bar with your hands at shoulder width. Bend your knees upward toward your shoulders as far as possible. Lower your legs and repeat.

IN-THE-WATER DRILLS AND WORKOUTS

DRILLS

There are many drills that the swimmer can do while in the water. Some of these drills are carried out without using the complete stroke. The swimmer can use a kick board, swim fins, weights, and hand paddles as a part of the workout. The swimmer will sometimes use only arm pulls or only leg kicks while working out. Some examples follow:

- Pull with hand paddles.
- Pull with hands clenched.
- Pull with only one arm.
- Pull with another swimmer holding onto legs.
- Kick only while on back or stomach with hands by side.
- Kick with swim fins while on back or stomach.
- Kick with arms at side, overhead, or straight out from shoulders.
- Swim with head up.

- Swim under water.
- Swim using kick and one arm.
- Swim using different breathing patterns with all strokes.

WORKOUTS

After warming up, the swimmer enters the water and begins a training workout. There are three categories or types of water workouts: lap swimming, timed swimming, and interval swimming. The swimmer also can conduct workouts using combinations of these, based on individual needs.

- Lap swimming consists of swimming a prescribed number of lengths. A length is 25 yards.

- Timed swimming consists of swimming a prescribed number of lengths in a specified amount of time.
- Interval swimming consists of swimming a prescribed number of lengths at maximum effort, alternating with swimming a prescribed number of lengths with an easy or slower effort.

HOW MANY? HOW LONG?

Your coach for the swimming activity will be able to provide some examples of swimming workouts. Workouts can be designed for the entire team or they can be tailored to improve individual swimmers. Some typical workouts are described in the “Swimming Workouts” chart.

SWIMMING WORKOUTS		
Lap Swimming	Amount	Stroke
Workout A Total = 20 lengths	20 lengths	front crawl
Workout B Total = 50 lengths	10 lengths 10 lengths 10 lengths 10 lengths 10 lengths	front crawl back crawl front crawl breaststroke front crawl
Timed Swimming	Amount	Stroke
Workout A Total = 15 minutes	5 minutes 5 minutes 5 minutes	front crawl back crawl breaststroke
Workout B Total = 40 minutes	10 minutes 10 minutes 10 minutes 10 minutes	swimmer's choice weakest stroke front crawl breaststroke
Interval Swimming	Amount	Stroke
Workout A Total = 525 yards	3 × 100 meters (300 yards) 3 × 50 meters (150 yards) 3 × 25 meters (75 yards)	2 front crawl 1 swimmer's choice 1 back crawl 1 breaststroke 2 front crawl 1 swimmer's choice
Workout B Total = 700 yards	4 × 100 meters (400 yards) 4 × 50 meters (200 yards) 1 × 100 meters (100 yards)	front crawl 2 back crawl 2 breaststroke front crawl

SWIMMING PRACTICE

PRACTICE SESSIONS

Practice sessions should be a standard part of the swimming activity participation. They can be a part of the regular troop meeting or can be held at a separate meeting. These sessions develop the Scouts both physically and mentally.

Many opportunities will occur to blend the sport of swimming with the game of life. Smart coaches and captains use these opportunities to strengthen the individual Scout as well as the Varsity team.

Practice sessions have four parts:

- 1. Warm-up and conditioning exercises.** Simple warm-up exercises, in and out of the water, allow for loosening of the muscles and help in avoiding injuries. Vary the pace and type of exercise. Questions should be asked to stimulate thinking about proper eating habits and the importance of exercise throughout life. This portion of the meeting should take about 10 minutes.
- 2. Skills development drills.** Teaching the fundamentals of competitive swimming may be necessary as a part of this meeting. It is essential that all team members understand the difference between recreational or fun swimming. Take time to teach some of these differences at every practice session and plan simple drills to reinforce the points.

Players should work both as individuals and in groups of two to four so that no one feels bored or slighted. This instruction should be brief to keep things moving and to save time for skill training in the water.

- 3. Team talk.** Make this a regular, normal part of practice. Use it for education and personal development. Team members should be encouraged to talk about such things as rules of the sport, principles of team play, team tactics, and concepts of fair play.

These rules, principles, tactics, and concepts apply to everyday life as well as to the sport of competitive swimming. These discussions should be a regular segment of practice as well as taking place at any appropriate time.

- 4. Practice.** Several practice groups should be going on at the same time. Team members in ability groups work to increase their individual skills.

These practice sessions should also include some general sessions on pool layouts, approaching and leaving the platform, rules of the sport, responsibilities of officials, etc.

CALL A TEAM PARENTS' MEETING

After you have had a couple of practice sessions, ask team members and their parents to attend a brief meeting. You may want to hold the meeting after a practice session or at a special time when most players and parents can attend.

Some ideas for the meeting follow:

- Introduce team leaders (coaches).
- Discuss practice and swim meet requirements and schedules.
- Distribute the schedule that the team will be following.
- Discuss the major points of the Varsity sports philosophy and clarify how this philosophy is being implemented.
- Explain the basics of competitive swimming and suggest some things that help make watching the swim meet more enjoyable.
- Talk about conduct during the competition, both in and out of the water. Ask parents to help you with this during the swim meets.
- Announce any special family events that are scheduled.

COACHING SWIM MEETS

Coaching a swim team during a meet is a great opportunity to get closer to your team. It's also an important time for the coach to model the kind of behavior he expects from his team members.

BEFORE THE MEET

- Get your team in a positive frame of mind.
- Remind them of the basic skills they have been working on in practice.
- Help them remember to think and play as a team.
- Suggest that they not worry about what their opponents might do, but concentrate on what they will do themselves.
- Review the important rules.
- Discuss proper conduct in the starting area and during warmups.
- Have the team do a few warmup exercises before the meet starts.

DURING THE MEET

- There should be very little coaching from the side-line. Coaching is done at practice, not when the meet is under way.
- When a swimmer has finished his swim, talk to him about how he could improve in specific areas.
- Compliment the swimmer on good performance. Present new ideas and suggestions. This is a helpful job for the assistant coach as well.
- Be aware of the influence of your own actions on the behavior of team members and spectators.
- Never leave the staging area except when absolutely necessary. Coaches are not allowed around the pool during competition except when given permission by the referee.
- Avoid shouting at officials when you feel they have made a bad call. (You may want to talk quietly to them between events or after the meet about specific calls.)
- Help team members keep cool when they lose their temper by first keeping cool yourself.

BETWEEN EVENTS

- Quietly review the improvements that swimmers should make in the next events.
- Avoid haranguing swimmers or intimidating them.
- Be cool and helpful, and keep your directions simple.
- Avoid sarcastic or negative comments about members of your team, the other team, or officials.

AFTER THE MEET

Encourage your team members to congratulate the other teams. Have a friendly talk with the other coaches or the officials. Bring your team together. Have everybody sit down and briefly discuss the swim meet by asking question such as these:

- What went well for the team today?
- Which swimmers on all of the teams really tried hard?
- Did we have a good attitude toward the other teams?
- What can we do better next time?
- What do we need to work on in practice?

You will think of many other questions to ask. The important thing to remember is to stimulate the thinking of your team members and let them talk to you and to each other.

Try not to lecture or preach. You can support the statements team members make that get your own feelings across. Guide the discussion and make it more than just a one-way communication from you to the team.

Wrap it all up by complimenting the team on a good effort and reminding them of the next practice or meet: the day, time, and location.

TENNIS CONTENTS

Background	77
Program Fields of Emphasis	78
Condensed Rules of Tennis	79
Tennis Practice	83
Warm-up and Conditioning Exercises.	83
Skills Development Drills	84
Practice Matches.	86
Coaching League Matches	87
Prevention and Care of Injuries	88
Glossary of Tennis Terms.	88

TENNIS

BACKGROUND



Handball and racket games that had elements of tennis have been played in Europe since the 1400s. Modern tennis was invented by an Englishman, Major Walter Wingfield, in 1873. Originally designed as a recreational activity that could be played on lawns, tennis has become one of the most popular recreational sports in America for players of all ages.

Almost every town and city has public tennis courts, which, in the United States, are usually made of asphalt or concrete-based material. Once rackets are in hand, it is an inexpensive sport. Since only two players are needed for tennis singles, it is easy to arrange games and practice opportunities.

This chapter begins with the basics of the sport. Sections on tennis practice, skills development, rules of the game, practice matches, league play, and prevention and care of injuries are also included. Members of the team will learn new meanings for the words *ace*, *alley*, *fault*, and *set* as they experience the sport of tennis.

The basic rules for tennis are simple and are the same everywhere in the world. These rules are established by the International Tennis Federation and are interpreted in the United States by the United States Tennis Association (USTA).

Tennis competition can be individual, as in a tennis tournament, or as a team sport. Tennis leagues for young players are available in many parts of the country. Entry-level leagues are organized through the USTA's National Junior Tennis League program. These leagues are often sponsored by local parks and recreation departments. Leagues that offer a wider range of levels are organized through the USTA's 17 sections. These leagues are called Junior Team Tennis.

THE BASICS

Tennis is basically a simple game. Two or four players exchange shots over a 3-foot-high net. Once the ball is served and returned, any ball can be hit before it bounces (a volley) or after one bounce (a ground stroke). The ball is hit back and forth until it goes into the net, bounces twice, or goes outside the boundaries of the court before bouncing.

When two players compete in tennis, it is called a **match**. All matches are based on games. A game is made up of individual points. In tennis, each point has

a name: 0 is called "love"; the first point is called 15; the second point is called 30; the third point is called 40; and the next point is "game." Games are grouped in sets, usually played until one player wins six games. The most common match in tennis is two out of three six game sets. This will result in scores such as: 6-3, 6-4, or 6-2, 6-0. League matches may be just one set to six or eight games, or even use alternative scoring such as that used in table tennis.

To play tennis, each player needs a racket and each court needs at least two balls. Each player should wear tennis shoes, which have flat, tough soles. Running shoes are not recommended for tennis.

Tennis players at every level (except in professional matches) play without officials. Each player calls his or her own "lines," that is, whether a ball bounces inside or outside the boundary line. This requires a great deal of honesty and trust. As a result, tennis is often cited as a good vehicle for developing independence, character, and sportsmanship.

A tennis match begins with a cooperative warm-up. Players flip a coin or spin a racket (up or down) to determine who serves first. Play continues, with the serve alternating, until one player wins the designated number of games.

THE TENNIS COURT

Tennis courts are the same size everywhere in the world. They are 78 feet long. In singles, the width of the court is 27 feet. For doubles, the alleys are added, making the court 36 feet wide. Each side of a singles court is divided into three areas. The two nearest the net are the service boxes and are 21 feet long and 13 1/2 feet wide. These are the target areas for the serve.

Tennis courts should have 15 to 21 feet of unobstructed space behind each end of the court and 10 to 21 feet between courts.

The net is 3 feet high at the center and 3 1/2 feet at the net posts.

PLAYER POSITIONS AND ROLES

In each game of singles (15-30-40-game), one player serves and one receives. In doubles, one player serves each game while the receiving team alternates on returns. In singles and doubles, only the server's position is restricted by the rules. The server must stand behind the baseline (the line farthest from the net) and between the center mark and the outside of the playing area.

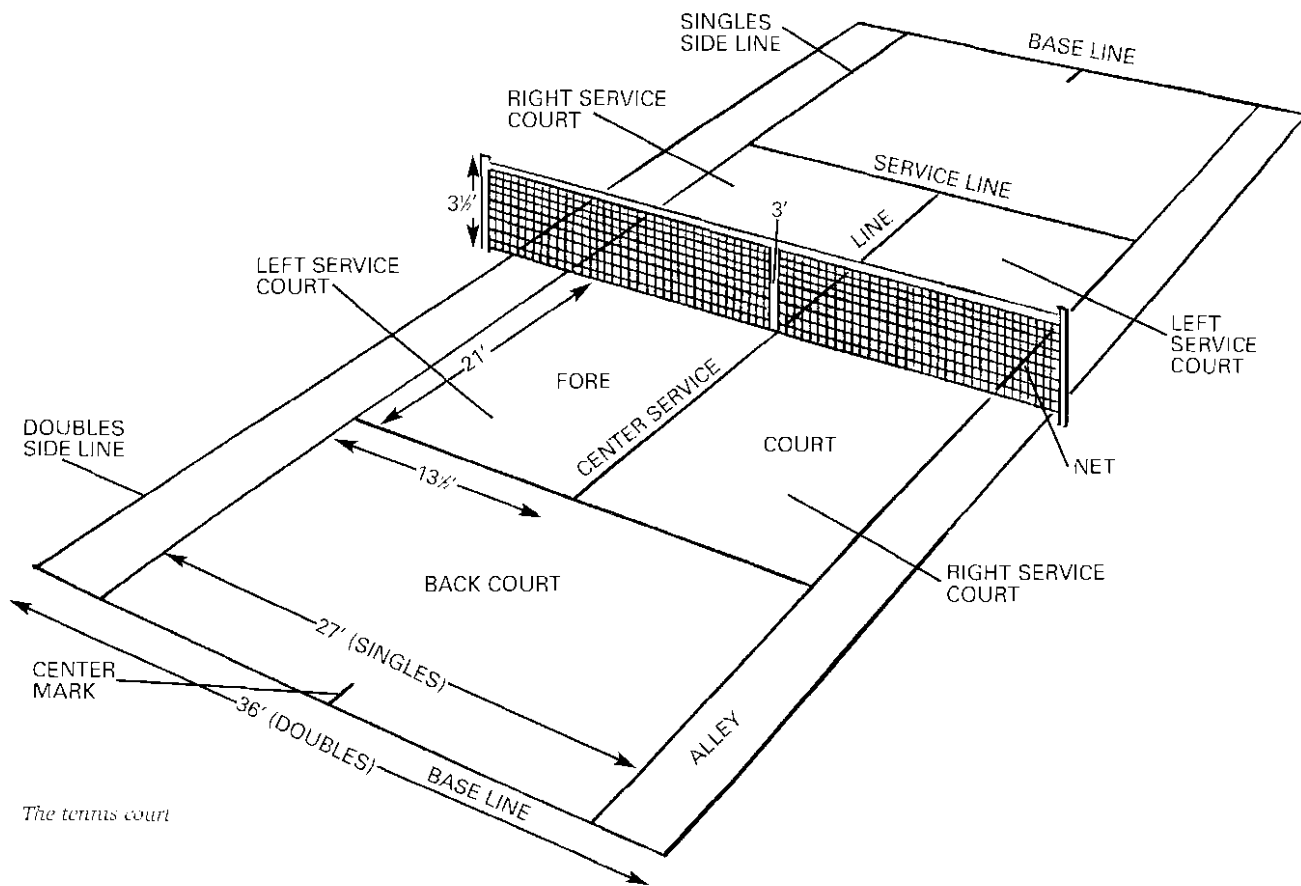

PROGRAM FIELDS OF EMPHASIS

The following ideas will help you plan a well-rounded program. Program managers carry out these ideas with help from a team committee member.

ADVANCEMENT

- Review each Varsity Scout's advancement status.
- Conduct a Sports merit badge clinic.
- Monitor the team advancement chart regularly.

HIGH ADVENTURE/SPORTS

- Program manager outlines or updates the team's annual special high-adventure event (Philmont, Florida Sea Base, etc.)
- Have a tennis tournament.

PERSONAL DEVELOPMENT

- Invite a religious leader to conduct a workshop on the importance of religion in daily life.

- Conduct a fitness session to strengthen muscles used in playing tennis.
- Invite a tennis coach to explain the basics of tennis.

SERVICE

- Clean up a community playground facility.
- Assist with the outdoor program of a new Boy Scout troop in your community.
- Lead a discussion on the importance of preserving natural resources.

SPECIAL PROGRAMS AND EVENTS

- Invite a representative from the National Park Service to discuss the opportunities for Varsity Scout teams to use park facilities.
- Attend a college or professional tennis match.

CONDENSED RULES OF TENNIS UNITED STATES TENNIS ASSOCIATION

The official rules of tennis are summarized below for the convenience of all players. In the preparation of this summary, no changes were made in the official rules, which have been established by the International Tennis Federation and are adhered to by the United States Tennis Association. Some technical aspects, however, such as specifications on court size, equipment, balls, and rackets, have been deleted here for the sake of brevity. For those who are interested in these specifications, they are covered in their entirety in the complete *Rules of Tennis*, which also includes interpretative cases and decisions and USTA comments.

Another invaluable reference for players is *The Code*, whose principles and guidelines apply to unofficiated matches. Players all over the world follow not only the official rules of tennis but also the traditions of sportsmanship and fair play found in *The Code*.

A familiarity with these rules and traditions is essential for achieving the greatest possible benefit and enjoyment from tennis.

THE SINGLES GAME

SERVER AND RECEIVER

The players stand on opposite sides of the net; the player who first delivers the ball is called the *server* and the other, the *receiver*.

CHOICE OF SIDES AND SERVICE

The choice of ends and the right to be server or receiver in the first game is decided by a toss. The player winning the toss may choose or require his opponent to choose (1) the right to be server or receiver, in which case the other player shall choose the end, or (2) the end, in which case the other player shall choose the right to be server or receiver.

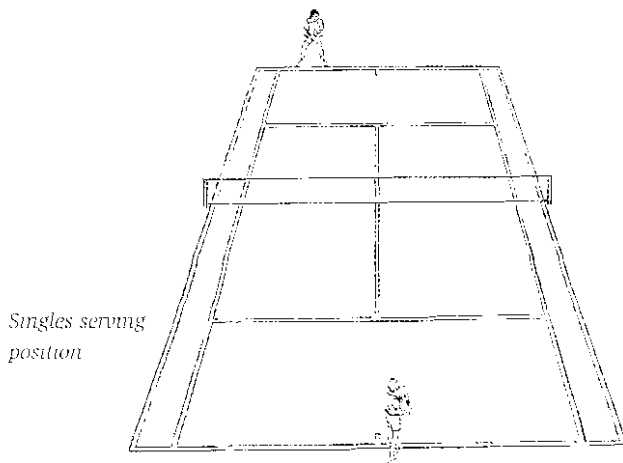

DELIVERY OF SERVICE

The service is delivered in the following manner: Immediately before commencing to serve, the server stands with both feet at rest behind the baseline and within the imaginary continuation of the center mark and the sideline. He should not serve until the receiver is ready.

The server then throws the ball into the air in any direction and strikes it with his racket before it hits the ground. Delivery is complete at the moment the racket strikes the ball.

RETURN OF SERVICE

The receiver may stand wherever he pleases on his own side of the net. However, he must allow the ball to hit the ground in the service court before returning it. If the receiver attempts to return the service, he is considered ready.

SERVICE FROM ALTERNATE COURTS

In delivering the service, the server stands alternately behind the right and left courts, beginning from the right in every game. The ball served passes over the net and hits the ground within the service court diagonally opposite, or upon any line bounding such court, before the receiver returns it.

If the ball is erroneously served from the wrong half of the court, the resulting play stands, but service from the proper court, in accordance with the score, is resumed immediately after this discovery.

FAULTS

The service is a **fault** if the server misses the ball in attempting to serve it, if the ball does not land in the proper service court, or if the ball served touches a permanent fixture other than the net, strap, or band before it hits the ground.

Throughout the delivery of the service, the server must not change his position by walking or running. A foot fault is called when the server touches the baseline or the imaginary continuation of either sideline or the center line while in the process of serving. However, having one foot in the air over one of these lines is not a foot fault.

SERVICE AFTER A FAULT

After a first fault (if it is the first fault), the server serves again from behind the same half of the court from which that fault was served. (If the service was a fault because it was served from behind the wrong half, the server is entitled to deliver one service from behind the proper half of the court.)

A SERVICE LET

During the service, a ball that touches the net but lands in the proper court is termed a "let" and counts for nothing. That one service is replayed. There is no limit to the number of let balls that may be made on the service; the server continues serving into the same court until a good service is delivered or two faults are made.

RECEIVER BECOMES SERVER

At the end of the first game, the receiver becomes the server and the server, the receiver; and so on alternately in all the subsequent games of a match. The players change ends at the end of the first, third, and every subsequent alternate game of each set, and at the end of each set, unless the total number of games in the set is even, in which case the change is not made until the end of the first game of the next set.

If a player serves out of turn, the player who ought to have served shall serve as soon as the mistake is discovered. All points scored before such discovery shall stand. If a game has been completed before such discovery, the order of service remains as altered.

SERVER WINS POINT

The server wins the point if the ball served, not being a let, touches the receiver or anything that he wears or carries before it hits the ground or if the receiver otherwise loses the point.

RECEIVER WINS POINT

The receiver wins the point if the server serves two consecutive faults or otherwise loses the point.

PLAYER LOSES POINT

A player loses the point if

- he fails to return the ball directly over or past the net before it has hit the ground twice consecutively;
- he returns the ball in play so that it hits the ground, a permanent fixture (other than the net, posts, singles sticks, cord or metal cable, strap, or band), or other object outside any of the lines that bound the opponent's court;
- he volleys the ball and fails to make a good return even when standing outside the court;
- he deliberately carries or catches the ball in play on the racket or deliberately touches it with the racket more than once;
- he or his racket touches the net, post, or ground within the opponent's court at any time while the ball is in play;

- he volleys the ball before it has passed the net;
- the ball in play touches him or anything that he wears or carries, other than the racket in his hand;
- he throws the racket at and hits the ball;
- he deliberately and materially changes the shape of his racket during the playing of the point;
- he deliberately commits any act that hinders his opponent in making a stroke.

A GOOD RETURN

It is a good return if

- the ball touches the net, posts, singles sticks, cord or metal cable, strap, or band, provided that it passes over any of them and hits the ground within the court;
- the ball, served or returned, hits the ground within the proper court and rebounds or is blown back over the net, and the player whose turn it is to strike reaches over the net and plays the ball, provided that neither he nor any part of his clothes or racket touches the net, posts, singles sticks, cord or metal cable, strap, band, or the ground within his opponent's court, and that the stroke is otherwise good;
- the ball is returned outside the posts or singles sticks, either above or below the level of the top of the net, even though it touches the posts or singles sticks, provided that it hits the ground within the proper court;
- a player's racket passes over the net after he has returned the ball, provided the ball passes the net before being played and is properly returned;
- a player succeeds in returning the ball, served or in play, which strikes another ball lying in the court;
- the ball touches any other permanent fixture after it has hit the ground within the proper court.

BALL FALLING ON LINE

A ball falling on a line is regarded as falling in the court bounded by that line.

A LET

In all cases where a let (other than a service let) has to be called under the rules or to provide for an interruption of play, the point shall be replayed.

If a player is hindered in making a stroke by anything not within his control, except a permanent fixture or deliberate interference by his opponent, a let shall be called.

COACHING

A player may not receive coaching during the playing of any match other than one that is part of a team competition.

THE DOUBLES GAME

The above rules apply to the doubles game except as below.

DELIVERY OF SERVICE

The server positions himself with both feet at least behind the baseline and within the imaginary continuations of the center mark and the sideline of the doubles court.

ORDER OF SERVICE

At the beginning of each set, the pair serving the first game decides which partner shall do so and the opposing pair decides similarly for the second game. The partner of the player who served in the first game serves in the third; the partner of the player who served in the second game serves in the fourth; and so on in the same order in all subsequent games of a set.

Doubles serving position

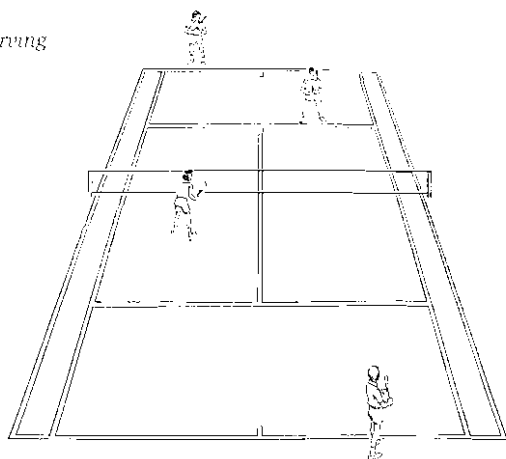

ORDER OF RECEIVING

The pair receiving the service in the first game of each set decides which partner shall receive in the right-hand court, and the opposing pair decides similarly in the second game of each set. Partners receive the service alternately throughout each game. The order of receiving the service shall not be altered during the set but may be changed at the beginning of a new set.

SERVICE OUT OF TURN

If a partner serves out of his turn, the partner who ought to have served shall serve as soon as the mistake is discovered, but all points scored and any faults served before such discovery shall stand. If a game has been completed before such discovery, the order of service remains as altered.

RECEIVING OUT OF TURN

If during a game the order of receiving the service is changed by the receivers, it remains as altered until the end of the game, but the partners shall resume their original order of receiving in the next game of that set in which they are the receivers.

SERVED BALL TOUCHING PLAYER

The service is a fault if the ball touches the server's partner or anything that he wears or carries. The server wins the point if the ball served (not being a let) touches the partner of the receiver, or anything that he wears or carries, before it hits the ground.

BALL STRUCK ALTERNATELY

The ball shall be struck by one or the other player of the opposing pairs in the course of making a serve or a return. If both of them hit the ball, either simultaneously or consecutively, their opponents win the point.

A GAME

If a player wins the first point, the score is called 15 for that player; on winning his second point, his score is called 30; on winning his third point, his score is called 40; and the fourth point won by a player is scored a game for that player except as follows:

If both players have won three points, the score is called *deuce*; the next point won by a player is scored *advantage (or ad)* for that player. If the same player wins the next point, he wins the game. If the other player wins the next point, the score is again called *deuce*; and so on, until a player wins the two points immediately following the score at *deuce*, when the game is scored for that player.

A SET

A player (or players) who first wins six games wins a set, except that he must win by a margin of two games over his opponent. Where necessary, a set is extended until this margin is achieved (unless a tiebreaker system of scoring has been announced in advance of the match).

The maximum number of sets in a match is five for men and three for women.

THE TIEBREAKER GAME

If announced in advance of the match, a tiebreaker game operates when the score reaches six games-all in any set.

In singles, the player who first wins seven points wins the game and the set, provided he leads by a margin of two points. If the score reaches six points-all, the game is extended until this margin has been achieved. Numerical scoring is used throughout the tiebreaker. The player whose turn it is to serve is the server for the first point; his opponent is the server for the second and third points; and, thereafter, each player serves alternately for two consecutive points until the winner of the game and set has been decided.

In doubles, the player whose turn it is to serve is the server for the first point. Thereafter, each player serves in rotation for two points, in the same order as determined previously in that set, until the winners of the game and set have been decided.

From the first point, each service is delivered alternately from the right and left courts, beginning from the right court. The first server serves the first point from the right court; the second server serves the second and third points from the left and right courts, respectively; the next server serves the fourth and fifth points from the left and right courts, respectively; and so on.

Players change ends after every six points and at the conclusion of the tiebreaker. The player (or doubles pair) who served first in the tiebreaker game shall receive service in the first game of the following set.

CODE OF CONDUCT

The highest type of sportsmanship is expected from every player. An understanding of and a commitment to the points highlighted here are a part of your responsibility as a player in a USTA tournament. **Violators of this code or its spirit are subject to disciplinary action.**

- Once you have entered a tournament, honor your commitment to play. Exceptions should occur only in cases of serious illness, injury, or personal emergency.
- From the beginning of the match, play must be continuous. Attempts to stall or to extend rest periods for the purpose of recovering from a loss of physical condition (such as cramps or shortness of breath) are clearly illegal.
- Intentional distractions that interfere with your opponent's concentration or effort to play the ball are against the rules.
- Spectators, including parents, friends, and coaches, are welcome to watch and enjoy matches. However, their role is clearly restricted to that of passive observer with **no involvement of any kind** during the match.

- Players are expected to put forth a full and honest effort regardless of the score or expected outcome.
- Players are expected to maintain full control over their emotions and the resulting behavior throughout the match. If you begin to lose your composure during play, try the following:
 - Take several deep breaths, exhale as slowly as possible, and feel your muscles relax.
 - Concentrate on your own game and behavior while ignoring distractions from your opponent or surroundings.
 - Be your own best friend—enjoy your good shots and forget the poor ones.

ON-COURT RULES*

- If you have any doubt as to whether a ball is out or good, you must give your opponent the benefit of the doubt and play the ball as good. You should not play a let.
- It is your obligation to call all balls on your side, to help your opponent make calls when the opponent requests it, and to call against yourself (with the exception of a first service) any ball that you clearly see out on your opponent's side of the net.
- Any "out" or "let" call must be made instantaneously (i.e., either before an opponent has hit the return or the return has gone out of play); otherwise, the ball continues in play.
- Do not enlist the aid of spectators in making line calls.
- If you call a ball out and then realize it was good, you should correct your call.
- To avoid controversy over the score, the server should announce the set score (e.g., 6-4) before starting a new game and the game score (e.g., 30-40) prior to serving each point.
- If players cannot agree on a score, they may go back to the last score on which there was agreement and resume play from that point, or they may spin a racket.
- Foot faults are not allowed. If an opponent persists in foot faulting after being warned not to do so, the referee should be informed.
- Do not stall, sulk, complain, or practice gamesmanship.
- Wait until the players on another court have completed a point before retrieving or returning a ball.

*Excerpted from the official USTA publication *The Code*, whose principles and guidelines apply in any match conducted without officials.

TENNIS PRACTICE

PRACTICE SESSIONS

Practice sessions should be a standard part of the tennis league season. They can be a part of the regular team meeting or can be held at a separate meeting. These sessions develop the Scout both physically and mentally.

Many opportunities will occur to blend the sport of tennis with the game of life. Smart coaches and captains use these opportunities to strengthen the individual Scout as well as the Varsity team.

Practice sessions have four parts, as follows:

- 1. Warm-up and conditioning exercises.** Simple warm up exercises, on and off the court, allow for loosening of the muscles and help avoid injuries. Vary the pace and type of exercise. Questions should be asked to stimulate thinking about proper eating habits and the importance of exercise throughout life. This portion of the meeting should take about 10 minutes.
- 2. Skills development drills.** Teaching fundamentals is essential at every level of tennis. Take time to teach basic skills at every practice session and plan simple activities to reinforce the points. Drills can be designed to be self-driven, so that two to eight players per court can work on a skill. Other drills need a leader to feed balls. A basket or hopper of balls helps keep these activities moving. Drills should be brief to keep things moving and to allow time for practice matches.
- 3. Team talk. Make this a regular, normal part of practice.** Use it as an opportunity for education and personal development. Team members should be encouraged to talk about such things as rules of the game, principles of team play, positions on the field, team tactics, and concepts of fair play.
These rules, principles, positions, tactics, and concepts apply to everyday life as well as to the sport of tennis.
- 4. Practice matches.** Use a mix of singles and doubles to keep everyone active. Players should have opportunities to play both singles and doubles. Tie in drill activities and team talk to the practice matches.

WARM-UP AND CONDITIONING EXERCISES

Healthy young players are always ready to play the game and rarely look forward to any preliminary exercises. It is important to avoid making the warm-up drudgery. Interpret its importance in helping get the players ready for strenuous exercise. The warm-up exercises used and the attitude about them will strongly influence the Scouts' lifetime attitudes about exercise.

Select new exercises for each practice, and also repeat some that have been done before. To begin, players position themselves in a circle, in double lines, or in a semicircle facing the leader. Let players take turns choosing and leading the exercises with the players.

Remember: Demonstrate the exercise or game first. Tell why the exercise is important. Have players do the exercise slowly together. Then exercise at regular speed.

STRETCHING EXERCISES

- **Deep breathing.** Ask players to take several breaths, expanding the chest fully by inhaling, then relaxing while exhaling.
- **Slow arm circles.** Walk in a circle. Swing arms forward and then backward.
- **Side benders.** With hands on hips, bend to one side, then the other.
- **Trunk twisters.** With hands on hips, twist to one side, then the other.
- **Toe touching.** Touch the opposite toe, with knees slightly bent.
- **Front thigh stretch.** Bend one knee. Grasp shin bone and pull the knee close to the chest.
- **Back thigh stretch.** Bend one knee and bring the heel up toward the backside. Grasp the ankle and pull it toward the backside.
- **Neck rotation.** Gently rotate the head from side to side.
- **Ankle rotation.** Rotate the foot without moving the knee, then with the knee rotating.
- **Thigh and leg stretch.** Take the position of a sprinter on the toes. Lower hips to the ground without moving the feet. Repeat on each side.
- **Forward crawl stroke.** Stretch arms forward in a crawling motion.

STRENGTH

- **Pull-ups.** Using an overhand grip on a horizontal bar, raise the body until the chin is above the bar. Lower the body slowly.
- **Sit-ups.** Lie on the floor. Pull feet back, raising the knees. Place hands on shoulders or behind the neck. Raise the body until the nose touches the knees.
- **Push-ups (modified).** Assume a hands-and-knees position on the floor. Bend arms and lower trunk until the chin touches the floor.
- **Isometrics.** Ball squeeze—Squeeze a tennis ball in each hand. Hold for eight to 10 seconds. Repeat.

AGILITY

- **Shuttle run.** Do wind sprints for 60 feet, then turn around and return to the starting point.
- **Footwork.** Standing with feet shoulder-width apart, run in place. Move left, right, forward, or backward on command of the exercise leader.
- **Jumping.** Place a 3-foot rod (dowel) between two cement blocks. Jump over the rod—back and forth, then left to right.
- **Jump rope.** Skip on both feet, on the left foot, then on the right foot; alternately skip from left to right to both feet.

SKILLS DEVELOPMENT DRILLS

Skills development should be focused on the needs of match play. To play tennis successfully, each player must have confidence in a number of different skills, such as forehands, backhands, volleys, and serves. Some players may be ready for immediate match play, while others need skill building. Check skills to make sure the activity is not too basic or too difficult for the players.

RACKET SKILLS

Players just getting acquainted with tennis can develop their skills with the following activities:

- **Down dribbles.** Players dribble balls from rackets to ground.
- **Up dribbles.** Players dribble balls in the air with rackets.
- **Invent-a-dribble.** Players invent different ways of dribbling the ball such as flip-flops (alternating faces on up dribbles); using the edge of the racket; while sitting down; while standing on one foot; etc.

- **Tennis relays.** In groups of three to five players, with one racket and ball per team, choose among the following: balancing ball on racket; dribbling down; dribbling up.
- **Sandwich relay.** Players in groups of four to six build a sandwich by piling one racket, one ball, then the next player's racket, etc. The group then tries to move up and back as a unit.
- **Tennis obstacle course.** Using dribbles (up or down), players proceed through an obstacle course of cones, hoops, chairs, or other available equipment.

BASIC FOREHAND DRILLS

Students who show good control with the above skills should move directly into hitting. Students who already have good hitting skills should be allowed to move into the rally drills that follow.

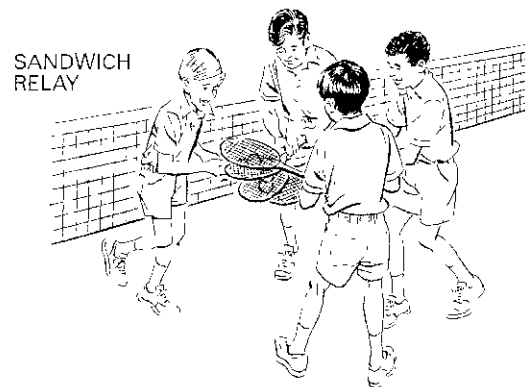
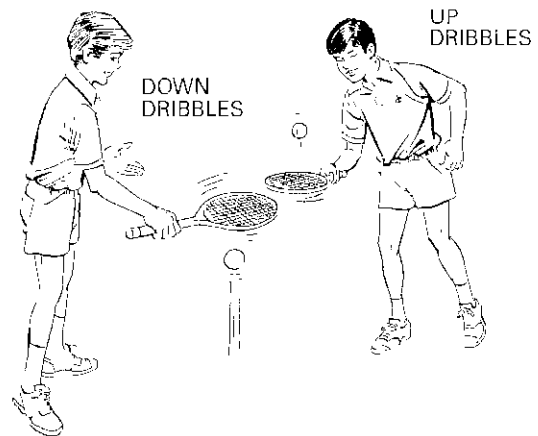

Racket skills

Coaching hints. For players to enjoy tennis, they must learn to hit with control. In early activities, encourage control by always using a target (on a wall) or having another student catch. Short, smooth strokes will help maintain control. Power can be added later.

- **Forehand grip.** Players should be encouraged to use a standard “shake hands” forehand grip.
- **Drop-hit-catch.** Players work in pairs. One player has a ball and racket; the other is the catcher. The hitter drops the ball and gently hits it to his partner, who is about 10 to 15 feet away. Score can be kept for each successful hit and catch, with partners rotating every five points.

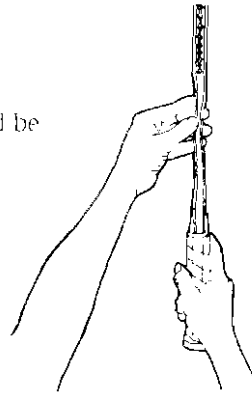

Forehand grip

- **Toss-hit-catch.** Players work in pairs. One player has a ball and racket; the other is the tosser and catcher. Score can be kept, with a point for each successful hit and catch, with partners rotating every five points.
- **Wall or backboard hits.** Using walls or wooden backboards, players work individually on hitting controlled forehands. Ball should bounce only once before being struck. Count consecutive hits.

BASIC BACKHAND DRILLS

- **Backhand grip.** All players should use either a standard one-handed backhand grip or a two-handed backhand grip.
- **Backhand bumps.** The hitter must face the target or tosser, with both feet pointed straight ahead. Player places strings of racket against opposite thigh and hits dropped or tossed ball by lifting the racket forward and upward.

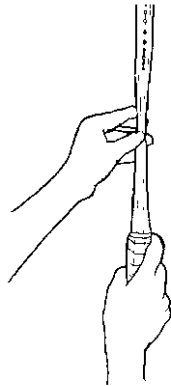

Backhand grip

- **Toss-hit-catch.** Players work in pairs. One player has a ball and racket, the other is the catcher. Hitter drops the ball and gently hits it to his partner about 10 to 15 feet away. Score can be kept for each successful hit and catch, with partners rotating every five points.
- **Alley-rally.** Players work in pairs. Each pair needs two rackets and three balls. Two target balls are placed approximately 4 to 5 feet apart. Players stand behind and to the side of the nearest target ball. One player starts a rally with the third ball. Using soft, high exchanges, the pair tries to hit each other's target ball.

BASIC VOLLEY DRILLS

- **Volley grips.** Beginners can use the same forehand and backhand grips. Players should eventually learn to volley with an in between (continental) grip to allow for fast reactions without a grip change.
- **Toss-volley-catch.** Players work in pairs. One player has a ball and racket; the other is the catcher. The hitter drops the ball and gently hits it to his partner about 10 to 15 feet away. Score can be kept for each successful hit and catch, with partners rotating every five points.
- **Hacky-sack tennis.** Players form small circles in groups of four to six and attempt to keep a ball in play by bumping it up from one racket to another. Players cannot hit twice in a row. Competition can be added by counting consecutive hits.



Continental grip

BASIC SERVING DRILLS

- **Service grip.** Beginners will be most comfortable with a forehand grip. As skill progresses, shift toward a grip between a forehand and backhand grip (continental).
- **Serving and throwing.** Since serving and overhand throwing are very similar, many players may be able to serve with little instruction. Have players throw a series of balls over the net from the serving position (behind the baseline). Then ask them to simply toss a ball into the air and “throw” the racket at the ball—without letting go of the racket.
- **Throwball.** Players simulate playing tennis points but throw the ball rather than use rackets. Players may catch the ball in the air or after one bounce and win points if opponents do not catch the ball or toss it into the net or out. This game can be played as singles or doubles.
- **Team serving.** Players form teams of three to six players and line up behind the baseline. Team members serve one at a time, and then return to the end of the line. The first team to hit 11 successful serves wins.

GROUND STROKE RALLY DRILLS

After players begin to have success with the basics, rally drills should be used to develop consistency. Long exchanges make tennis exciting and fun, and they promote vigorous exercise. Building rally skills should be a major goal of skills development drills at this level.

- **Short tennis.** Players compete in mini-matches using just the four service boxes of a regulation tennis court. Short tennis can also be played on gymnasium floors and schoolyards.
- **Short and long.** Players work in pairs over a net. Both players start quite close to the net and begin a rally. With each successful shot, they move a step back. After every error they start back very close to the net. The goal is to work all the way back to the baseline.
- **Consecutive rally game.** Players work in pairs over a net. Players attempt to set a group record for the number of successful shots in a row. Start from service line to service line (half-court) and with success have pairs back up gradually to the baselines. This game can be played straight ahead or on a diagonal, with two or four players per court.
- **Ground stroke-approach-volley-overhead.** Players form a single file line on one baseline. The coach or leader starts with a bucket of balls on the opposite baseline. Each player will hit four shots that are fed by the coach. The first is a forehand or backhand ground stroke, the second is a short ball that is followed to the net, the third is a volley, and the fourth, an overhead smash.

PRACTICE MATCHES

TENNIS WORK-UP

Two players defend the baseline on one side of the net. On the other side, the remaining players (four to eight) form a single-file line behind the baseline. The coach or leader starts the drill from behind the two defenders by hitting a soft, short ball into one of the service boxes. The first player in line runs in and hits the ball, taking a net position. If the attacking player wins the point, then this player takes the place of one of the two defenders.

AROUND THE WORLD

Players form equally sized single-file lines on opposite baselines. The first player in line drop-hits a ball to the first person in the opposite line, and then must run around the court past the right net post to the end of

the line at the other side of the court. Play for consecutive hits, or as an end-of-practice elimination.

TEAM LOB AND SMASH

Each court has two teams. Two members of one team will begin at the net, while two from the other team will defend from the baseline.

The net team will begin the point with an easy drop-hit to either baseliner, who must then attempt a lob. Each time a successful return is made using a lob, a point is scored for the lobbers. Smashers get points when lobs are missed or by hitting a winning smash. Switch roles after 11 points.

KING OF THE COURT

Two or more courts are needed for this game. This is a progressive work-up game in which players play 1-point singles matches. The goal of the game is to work to the “top of the hill” and to stay there by beating challengers. Two players are assigned to each court. All remaining players line up at the farthest court from the “championship court.” Winners on each court move toward the championship court. Those who lose remain where they are, except on the championship court, where they are vanquished back to the end of the line. The challenger on each court receives the serve.

DOUBLES CHALLENGE COURT

One team takes on challengers in a short two-out-of-three-point match. The winning team “keeps the court.” This rotation can allow for a large number of players on a few courts. If enough courts are available, matches can be expanded to a 12-point tiebreaker.

TENNIS 21

Players form two lines on the baseline opposite the coach or leader. The first player in line hits one ground stroke (forehand or backhand), and then runs in to volley a second shot. Two points are awarded for each successful ground stroke, one for each volley. The first player to achieve 21 points wins.

FORGOT-MY-RACKET DOUBLES

Players compete in a regular doubles game, except that each team is allowed only one racket. Teams must alternate hits and pass the racket back and forth without dropping it.

COACHING LEAGUE MATCHES

Coaching tennis matches is a great opportunity to get closer to your team members. Matches give your players the opportunity to demonstrate their skills and sportsmanship. It's also an important time for the coach to model the kind of behavior expected by the team members.

BEFORE THE MATCH

- Get your team in a positive frame of mind.
- Remind them of the basic skills they have been working on in practice.
- Suggest that they not worry about what their opponents might do, but concentrate on what they will do themselves.
- Review the important rules.
- Caution against arguing with opponents on close calls.
- Discuss proper conduct during warm-ups with opponents. Have the team do warm-up exercises before the match starts.
- Begin with two or three stretching exercises.
- If possible, either at the match site or at other courts, allow players to warm up by hitting all the shots they might use in a match.
- Emphasize tennis etiquette: greeting and shaking hands with opponent, having a friendly and cooperative warm-up, and shaking hands after the match.
- Let players know that everyone can be a winner in a tennis match—by trying hard and playing fair, and by learning something from the experience.

DURING THE MATCH

- Behavior problems should be dealt with firmly and quickly. If your team rules are violated, then the offending player must be immediately defaulted, regardless of impact on the team match.
- Technical coaching is best done in practice, not during or immediately after the match. Note the areas that need attention for future practice sessions.
- Help keep players cool when they are tempted to lose their temper by first keeping yourself cool.

AFTER EACH MATCH

Let your players know you are interested in more than the score. Instead of saying "Did you win?" or "What was the score?" try "Did you give it your best?" or "Did you stick with the game plan?" Encourage your players to congratulate the other team. Have a friendly talk with the other coach. Bring your team together. Have everybody sit down and discuss the matches by asking some questions such as these:

- What went well in your matches today?
- Did you feel you gave your best effort?
- Did you use what we worked on in practice?
- Did we show a good attitude toward our opponents?
- What can we do better next time?
- What do we need to work on in practice?

You will think of many other questions to ask. The important thing to remember is to stimulate the thinking of your players and let them talk to you and to each other.

Try not to lecture or preach. You can support those statements players make that get your own feelings across. Guide the discussion and make it more than just one-way communication from you to the team.

Wrap it up by complimenting the team on a good effort and reminding them of the next practice or game day, time, and location.

PREVENTION AND CARE OF INJURIES

Tennis is a relatively safe sport for players, but since it could involve bodily contact, injuries may occur.

All Varsity team sports are as safe as the environment established by adult leaders for the sport. Tennis coaches should take precautions to help prevent injury and be prepared to respond when they do occur.

SAFETY CHECKLIST	
<input type="checkbox"/>	Facilities are in good repair and clear of any obstructions around the court.
<input type="checkbox"/>	Teams warm up properly before practice sessions and games.
<input type="checkbox"/>	Rules and equipment are modified to adjust the physical demands of the sport to the developmental level of players.
<input type="checkbox"/>	Teams are properly supervised and coached during practice sessions and games.
<input type="checkbox"/>	Coaches know the proper emergency steps to take when accidents do occur.
<input type="checkbox"/>	Players do not play when hurt.
<input type="checkbox"/>	Players are taught how to prevent blisters by wearing footwear that fits properly, gradually breaking in new shoes, and wearing two pairs of socks when needed.
<input type="checkbox"/>	Players are taught to treat bruises and sprains with ice packs to reduce swelling and pain.
<input type="checkbox"/>	Practice sessions are reasonable in length and planned to include brief rest periods.
	The emphasis should be on prevention of injury through proper warm-up, conditioning, supervision, and education.
	Players should be conditioned properly for match play. When injuries do occur, it is necessary to be familiar with the immediate recommended treatment. First aid is the immediate handling of athletic injuries. If pain persists, refer to family physician for follow-up.

GLOSSARY OF TENNIS TERMS

Ace. A ball that is served so well that the opponent fails to touch it with his or her racket.

Ad. Abbreviation for advantage. It is the first point scored after deuce. If the serving side scores, it is "ad in"; if the receiving side scores it is "ad out."

Alley. The area between the singles and doubles sidelines.

Approach. A shot that is followed to the net.

Backcourt. The area between the service line and the baseline.

Baseline. The line 39 feet from the net that runs parallel to it at either end of the court.

Deuce. A game score when both players have three or more points (40-40 or more).

Double fault. When a player loses a point by missing both serve attempts.

Doubles. A match with four players, two on each team.

Fault. A missed serve.

Forehand. The stroke used to return balls hit to the right side of a right-handed player.

Game. The part of a set that is completed when one player or side wins four points, or wins two consecutive points after deuce.

Ground strokes. Strokes made after the ball has bounced, either forehand or backhand.

Let. A point played again because of interference.

Lob. A ball hit high enough in the air to pass over the outstretched racket of a net player.

Love. Zero, no score.

Point. Four points win a game (15, 30, 40, game) unless both sides have three points (deuce); one side must then score two points in a row to win.

Rally. A series of good hits made in a row.

Set. A scoring unit awarded to a player who has won six or more games with a two-game margin, or who has won the 13th game in a tiebreaker.

Injury	Suggested First Aid
Muscle pulls, sprains, and bruises	Use ice pack immediately to reduce swelling. Speed of application is essential.
Small cuts	Apply pressure to reduce bleeding. Wash with cleaning solution and apply sterile dressing if necessary.
Nosebleed	Have player pinch nostrils and hold until bleeding stops. Apply ice pack.
Foreign body in eye	Pull upper lid down, holding eyelash. Wash out with eye cleaning solution. If substance is not removed, refer to physician.
Fainting or loss of wind	Rest in cool place. Try to relax player and slow down breathing.
Scrapes and court burns	Wash with cleansing solution. If necessary, cover with gauze.
Elbow or knee injuries; jammed finger or toe	Elevate area and apply ice pack. Refer to physician if pain persists.
Shin injury	Apply ice pack and compression. Refer to physician if pain persists.
Back or neck injury	Keep the player calm. Do not attempt to move or sit the player up if pain is severe. If pain is slight, apply ice pack.
Blister	Keep clean, wear two pairs of socks, puncture if necessary to relieve pressure. Remove dead skin for quicker healing.

Remember: Never send a hurt player back into practice or a match. First aid is the immediate handling of athletic injuries. Refer a hurt player to the family physician for follow-up treatment if pain persists.

Singles. A match between two players.

Smash. A hard overhead shot.

Straight sets. To win a match without the loss of a set.

Tiebreaker. A system used to decide a set when the score is 6-6.

Volley. A stroke made by hitting a ball before it has touched the court, excepting the serve.

ACKNOWLEDGMENTS

The Boy Scouts of America gratefully acknowledges the assistance of Lawrence Tabak, National Administrator, USTA Schools Program, and the United States Tennis Association for their help in the preparation of this chapter.

TRIATHLON CONTENTS

Background	91
Program Fields of Emphasis	92
The Playing Field	92
Condensed Rules for Triathlon	92
Triathlon Practice	95
A Guide for the 12-Week Triathlete	95
Glossary of Triathlon Terms	103

TRIATHLON

BACKGROUND



In the early 1970s, members of the San Diego Track Club sought a break from the rigors of training for running marathons and 10k runs. Bike riding and swimming were suggested as possible alternatives. In 1974, the activities were combined into the first swim/bike/run triathlon competition, held at San Diego/

Mission Bay, California.

A *triathlon* is a long-distance race that consists of three phases (such as swimming, bicycling, and running).

A *triathlete* is an athlete who competes in a triathlon.

After having been a participant in the first Mission Bay Triathlon, U.S. Naval officer John Collins brought the concept to Hawaii. In 1978 the first triathlon was conducted in Hawaii by combining the Waikiki Rough Water Swim, the Around-Oahu Bike Ride, and the Honolulu Marathon. Never before had anyone attempted all three events in the same day. It was said at the time that whoever could do all three events in one day, back to back, surely could call himself an "iron man."

Twelve men completed that first Ironman race in 1978. Only 13 men and one woman crossed the finish line in 1979, but a feature article by Barry McDermott in *Sports Illustrated* about the 1979 race caught the attention of athletes and ABC's "Wide World of Sports." The event had its first network TV coverage in 1980 and saw participation increase tenfold.

The United States Triathlon Association (now known as Triathlon Federation/USA) was founded in 1982. Triathlon Federation/USA (Tri-Fed/USA) is the national governing body for the sport of triathlon in the United States. Tri-Fed/USA seeks to create an environment that fosters fair and safe competition for triathletes at all levels. Tri-Fed/USA focuses on rules and safety, drug control, age-group and master's competition, elite/pro triathletes, officials and officiating, and numerous other areas of concern.

The first race of the United States triathlon series was held in 1982, ushering in an era of mass participation in the sport and introducing age-group-oriented triathlons. The Nice Triathlon, held that same year on the Cote d'Azur in France, was Europe's first swim/bike/run event.

From its beginning as simply a break from training, the sport of triathlon has had rapid growth. While the Ironman is the most widely recognized triathlon in the world, its 2.4-mile swim, 112-mile bike ride, and full 26.2-mile marathon are distances that no triathlete takes lightly. Most triathlons are about one-third as long as the Ironman. Tri-Fed/USA recognizes four distance categories: short, international, long, and ultra.

Distance Category	Swim (miles)	Bike (miles)	Run (miles)
Short	.24-.62	5-15.5	1-3
International	.62-1.2	15.5-31	3.1-6.2
Long	1.2-2.5	31-61	6.2-19
Ultra	2.0+	62+	19+

For triathlons, two of the three segments will determine the distance category. For example, an event with a .5-mile swim, a 25-mile bike ride, and a 6.2-mile run would be considered an international-distance event. (The bike and run determine the distance category in this example.) Race tactics and training regimens will differ in each category. A short race is considered as much a triathlon as is the ultra.

Triathlons do not have to be swim/bike/run events. Most are and likely will continue to be. However, the Mountain Man Winter Triathlon in Colorado, for example, is composed of cross-country skiing, snowshoeing, and speed skating.

The Varsity team will determine the composition of the triathlon as well as the distances for each segment. Consideration must be given to the team's geographic location, the season of the year, the facilities available, and the wishes of the team membership.

No one ever dreamed that the sport of triathlon would gain so much popularity in so short a span of time. Represented by the International Triathlon Union (ITU), the sport has been recognized by the General Association of International Sports Federation (GAISF) and the International Olympic Committee (IOC).

PROGRAM FIELDS OF EMPHASIS

The following ideas will help you plan a well-rounded program. Program managers carry out these ideas with help from a team committee member.

ADVANCEMENT

- Review each Varsity Scout's advancement status.
- Conduct a Personal Fitness merit badge clinic.
- Monitor the team advancement chart regularly.

HIGH ADVENTURE/SPORTS

- Program manager outlines or updates the team's annual special high-adventure event (Philmont, Florida Sea Base, etc.).
- Plan a triathlon event for the team.

PERSONAL DEVELOPMENT

- Develop a personal training program for each team member.
- Conduct a session on ethical decision making.
- Invite a representative from a local chapter of the American Cancer Society to present a program on ways to protect yourself against cancer.
- Participate in a 5k run or a bike race

SERVICE

- Contact and carry out a reading program for a retirement center.
- Assist with traffic control at a local athletic event.
- Conduct a flag ceremony at a local high school for one month.

SPECIAL PROGRAMS AND EVENTS

- Have a parents' night to share the latest team activity.
- Participate in a local community festival or celebration.

THE PLAYING FIELD

The playing field for the sport of triathlon is a bit different from those for other sports. Triathlons consisting of swim/bike/run, for example, require a body of water (usually a lake or ocean), an improved bike trail or road, and a running surface that can be controlled. Triathlons having segments other than swim/bike/run will require different physical facilities. Consideration also must be given to the transition areas. These areas

must be large enough for the triathlete to make the transition from one segment to the next. To accommodate all of the needs for a specific triathlon, the events may be held in the community where the team is located or may be held at a location that requires the team to travel.

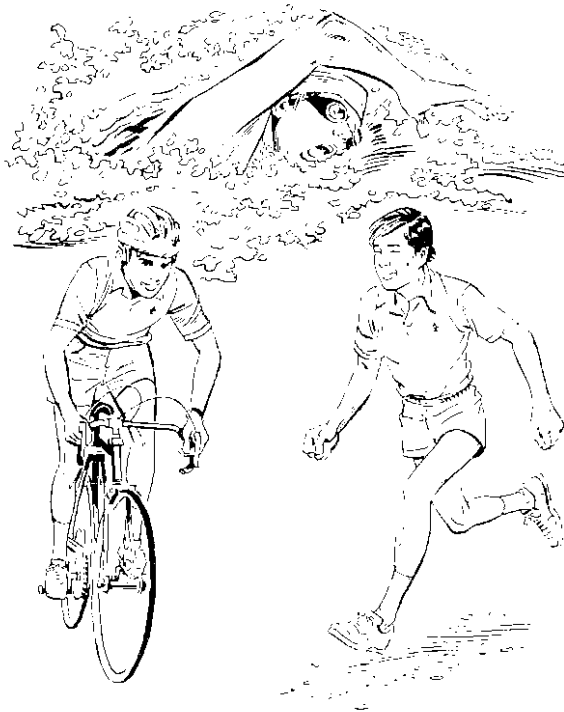

CONDENSED RULES FOR TRIATHLON

Specific rules are set forth for triathlons that are sanctioned by Tri-Fed/USA. These condensed rules and procedures follow the Tri-Fed/USA manual as a guide. Varsity teams participating in triathlons must follow the competitive rules set forth by the organization that sponsors or conducts the event. Condensed rules for a swim/bike/run triathlon are listed below. If other events are used, a set of rules for those segments must be developed.

PREPARATION AND TRAINING

No person may participate in a triathlon unless he or she is in good health and has had training for all the segments to be used in the race. Annual physical exams and properly conducted team practice sessions must take place.

AGE-GROUP COMPETITION

Age-group competition is determined by the participant's age on the day of the race.

GENERAL CONDUCT

All participants must comply with the rules set forth for the event. Proper conduct is expected so as not to offend competitors, officials, volunteers, and spectators. Fairness, respect, and courtesy to all involved are mandatory. If a participant violates any rules, he or she must report the violation to the head referee or retire from the race.

RACE CONDUCT

Participants must cover the prescribed racecourse in its entirety or withdraw. Participants shall refrain from intentionally or accidentally blocking, charging, obstructing, or interfering with the forward progress of another participant. Assistance in any form, including food, drink, equipment, support, pacing, or replacement of equipment or parts, may be taken only from race officials. The participant's number must be visible at all times. Glass containers of any kind are prohibited. Any item deemed dangerous or equipment determined to be improper by the head referee may not be worn or used. No participant shall commit any act that could cause injury to any participant.

PENALTIES AND PROHIBITED CONDUCT

Penalties, including disqualification or assessment of a time penalty, may be imposed on any participant violating any competitive rule.

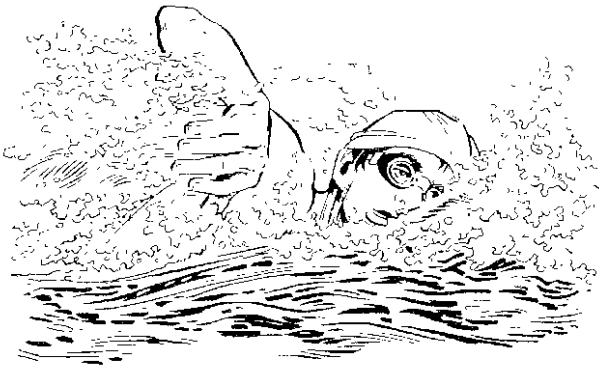

SWIMMING CONDUCT

A swimmer may use any stroke to propel through the water and may tread water or float. When resting, a participant may stand on the bottom or hold an inanimate object such as a buoy, boat, rope, or floating object. Excluding the floor of the pool, lake, or ocean, a participant may not use any inanimate object to gain forward motion. Swimmers experiencing difficulty should signal for assistance by raising an arm overhead and pumping it up and down. The official rendering aid will determine if the participant may continue or must withdraw from the race. The wearing of wet suits shall

be determined by the race director. Water temperature shall be checked within two hours of the race at a depth of 18 inches. Measurements are made in at least three locations along the course, spaced so as to divide the entire swim course into approximately equidistant segments, at points where sunlight strikes the water. At no time should a swimming segment be conducted when the water temperature places the participants in a dangerous situation. Swimmers must wear a brightly colored swim cap. Swim goggles or face mask may be worn by the swimmer if desired. Fins, gloves, paddles, flotation devices, or any other propulsion devices shall not be worn. Triathlons having many participants will start the swimming segment in "waves" or groups. Participants must start in the wave or group to which they are assigned.

CYCLING CONDUCT

All bicycles must be propelled by human power. Forward progress along the cycling segment must be made while accompanied by the participant's bicycle. The bicycle may be ridden or carried in a safe manner. The participant must follow the prescribed course and obey all traffic laws. Approved safety helmets are mandatory. The helmet must be securely fastened before mounting the bicycle and may not be removed until the participant has dismounted. Extreme caution must be taken when mounting, dismounting, or when passing an accident so as not to endanger any other participant. Drafting other participants or motor vehicles so as to gain an advantage is not permitted. Except for reasons of safety, all participants must keep to the right of the course unless passing. The passing lane is to the left of the course unless otherwise prescribed. Passing is permitted only when space is adequate and the cyclist is confident of his or her ability to make the pass. Bicycle specifications are determined by the sponsor or organization conducting the triathlon.

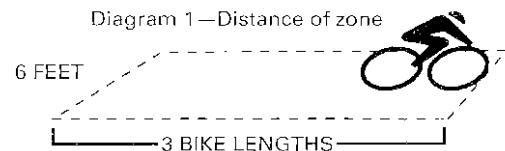

A is acting as the lead cyclist. B is maintaining a static distance within two bike lengths of the rear of A, and B is not attempting to pass A. B is drafting A.

Diagram 3—Drafting

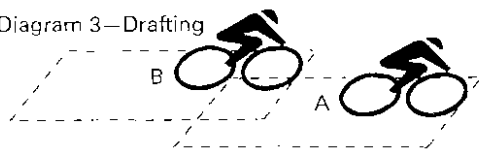

B is drafting A unless he is attempting to pass A.

Diagram 4—Not Drafting

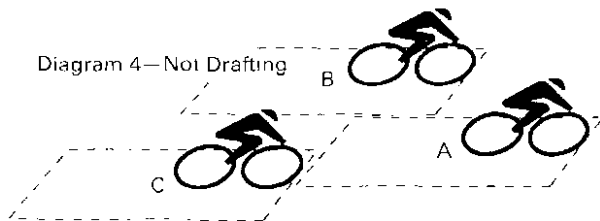

B and C not drafting A or one another. Both B and C may maintain a static position with A without being called for drafting.

Diagram 5—Not Drafting

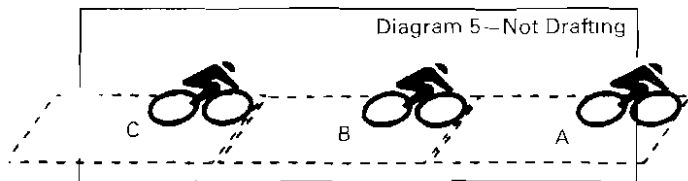

A, B, and C are maintaining adequate separation front or rear even though they are in tandem. They cannot be called for drafting.

Diagram 6—Not Drafting

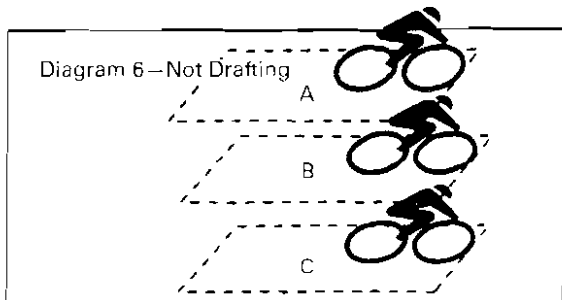

A, B, and C cyclists are maintaining adequate separation between one another even though they are abreast of one another. They can maintain a static position and not be called for drafting.

Diagram 7—A Pack Drafting

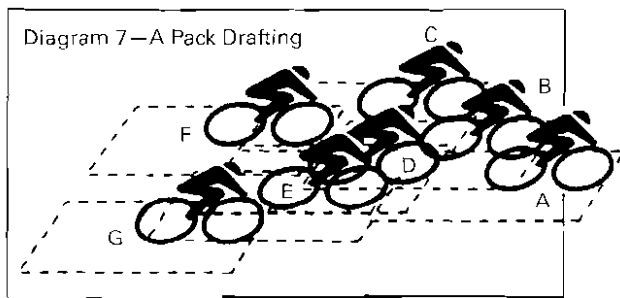

Except for A, all triathletes are drafting and must break the pack.

RUNNING CONDUCT

A participant must run or walk the entire portion of the run course. Crawling to gain forward progress is not permitted. Unless for safety reasons, the prescribed course must be followed. A participant may carry a water bottle made of a substance other than glass. Headsets, radios, headphones, or any object to gain advantage may not be worn.

TRANSITION AREAS

Transition areas are located at the end of the swimming and cycling segments for the participant to end one and begin the next leg of the triathlon. Participants must approach and leave these areas in a safe manner. Equipment and clothing are located in individually designated spots and must be placed in these spots in a proper manner. For example, bicycles are placed in a corral in an upright position. While in the transition area, participants may not impede the forward progress or interfere in any way with other participants. Changing areas are provided by the sponsor or organization conducting the event. Public nudity is not permitted.

MEDICAL CONTROL RULES

Use of substances or practices of any kind aimed at artificially enhancing the athlete's performance is prohibited. Triathlons sanctioned by Tri-Fed/USA require medical control tests to determine the chemical content of the athlete's body. Many prescription drugs contain chemicals that are considered "banned substances." A complete list of banned as well as permitted upper limits on other chemicals such as caffeine will be provided to participants.

RACE OFFICIATION

The race officials at all events shall consist of a head referee, marshals, judges, and a head timer.

The head referee's decisions are final and binding from the start of the event until the scores are finalized. The head referee has total responsibility for the event, including interpretation and enforcement of competitive rules, conduct of participants, invoking and imposing penalties, performance of other race officials, safety of the course, examination of equipment used by participants, and any other actions necessary to ensure that the triathlon is conducted in a proper manner. The head referee shall wear distinctive clothing and be positioned in a designated location near the finish line so as to properly administer all phases of the race.

Race marshals are assigned to the swim, cycle, and run portions of the event, as well as to the transition areas. They follow the instructions of the head referee. Race marshals have jurisdiction over all persons in their respective areas of assignment. They monitor the events to ensure safety and compliance with the rules of competition. Violations are reported to the head referee. Only the head referee assesses penalties.

Judges hear and rule on all protests that participants may lodge for penalties assessed to them. Judges also assist other race officials as instructed by the head referee.

The **head timer** is responsible for collecting and processing all data relevant to the calculation and determination of race officials.

PROTESTS

From time to time an athlete may disagree with the decision of the head referee to assess a penalty. Procedures for filing a protest will be included in the competitive rules provided or made available to triathlon participants.

TRIATHLON PRACTICE

PRACTICE SESSIONS

Practice sessions should be held when the Varsity team members are preparing to participate in a triathlon. Practice sessions can be a part of the team meeting or be held at a separate meeting. These sessions develop not only the physical side, but also the mental side of the Scout.

- 1. Warm-up and conditioning exercises.** Simple warm-up exercises allow for loosening the muscles and help to avoid injuries. Vary the pace and type of exercise. Questions should be asked that stimulate thinking about proper eating habits and the importance of exercising throughout life. This portion of the meeting should take about 10 minutes.
- 2. Skills development.** Teaching the fundamentals is essential in every category of triathlon. Scouts face the challenge of participating in what amounts to three different sports at the same time. Time must be taken at each practice session to introduce the basics of each event and at the same meeting reinforce the basic skills learned in the other sports.

Team members should work in groups of two or three to keep everyone involved. The same triathlon segment might be covered in each group or the groups might focus on different areas where they need a little extra work.

- 3. Team talk.** Make this a regular, normal part of practice. Use it as an opportunity for education and personal development. Team members should be encouraged to talk about the triathlon rules of competition, especially if participating in a sponsored race for the first time. These rules are no different from the rules the Scout faces in his everyday life.

- 4. Practice.** This is the part of the meeting to which the Scout looks forward. These sessions should relate to the skills development portion of the meeting.

A GUIDE FOR THE 12-WEEK TRIATHLETE

The most difficult thing about becoming a triathlete is getting through the first race. After that, it will seem like a snap, but reaching that point seems impossible sometimes, especially if there aren't many triathletes in the area to offer encouragement and advice. There is a lot to accomplish before approaching a starting line. A triathlete has to develop endurance and technical competence for three separate sports and balance multiple workouts; there's equipment to buy and an endless variety of products from which to choose; and there are dietary concerns to consider, as well as a host of physiological details. And you probably thought that the actual triathlon was going to be the hard part!

Tri-Fed/USA and the Boy Scouts of America want to make that first triathlon (or perhaps the first serious triathlon season) as positive an experience as possible. The purpose of this chapter is to provide the necessary fundamentals to develop an effective training program leading to your first race, presumably an international-distance triathlon comprising a 1-mile swim, a 25-mile bike ride, and a 6-mile run.

To begin with, you should be moderately fit and in good health. If you've been inactive for some time, it's advisable to undergo a general physical. We'll assume that within one hour for each sport, you can swim 1 mile, bike 15 miles, and run 6 miles. If you can do that much, you're ready to begin now. If not, work on your weaknesses. We've included many tips on physiology and proper technique for swimming, biking, and running that will help bring you up to par. Then begin this 12-week plan.

Goals are particularly important, regardless of the length of the race you want to enter. Without them, using this training guide is like trying to use a map before you know where you want to go. Set a goal and aim for it. You can readjust your sights, or the goal itself, but all changes you make in your program should

be considered carefully. If you decide that you want to undertake this program—whether it's the simple approach or the complicated, scientific one—stick with it. If you go on and off the program, you'll still be waiting next year to do your first race.

To make the most of this training program, keep a log recording your workout, the type of terrain you run or cycle on if it's notably hilly or mountainous, and how you felt afterward. This information will come in handy in the future if you try to analyze what you were doing right or wrong in the past. Select a training partner to add fun and keep your motivation up.

Your team might choose to become members of or seek the resources of a local triathlon club. This resource will assist you by providing feedback or discussion that will promote your understanding of training principles. Check the club directory in your telephone book, or ask at local athletic or bike stores to find clubs or partners.

Finally, we'd like to offer some advice about what to forget: Have you heard the old saying, "No pain, no gain"? That's a sure recipe for disaster. You should enjoy this training, and if you don't feel good about it—if your body doesn't feel better and stronger—you're doing something incorrectly. Pain is a signal that something is wrong; get that message. You need to listen to your own body; the more you try, the more you pay attention, the more it will communicate to you.

If you begin to experience any chronic pain in muscles or joints, give them a rest. If that doesn't fix it, look for a sports medicine specialist; no one understands sports physiology and training more than the specialists.

Now you're ready to begin your program. Take it slowly and treat it as a learning experience. Find a good target triathlon, get ready, get set, and go for it!

GETTING STARTED

The first thing you should get into the habit of doing if you intend to take training seriously is to monitor your resting pulse and weight. Over time, if your training program is effective, your resting pulse should drop. Meanwhile, unless you're over- or underweight to begin with, your body weight should remain relatively constant. Wide fluctuations of either indicator means that something is wrong and it's time to pay attention.

Your resting pulse should drop because, as you get into shape, the heart delivers more blood, and therefore oxygen, with each beat; fewer beats accomplish the same amount of work. As your program progresses, you'll notice a lower pulse rate. However, if one day, or over several days, your resting pulse shoots up, it means that your body is under some kind of stress; it may signal an impending illness or overtraining fatigue. You should take it easy for a few days and reduce the stress.

Sudden weight loss that has no explanation is also a possible indicator of overtraining. (If you went for a long, hard workout yesterday and then missed a meal or two, you have an explanation.) In general, though, you want to make sure that your eating habits keep pace with your training.

The best time to monitor pulse and weight is first thing in the morning. As soon as you wake up, and before you get out of bed, take your pulse for 60 seconds to find your resting pulse. Then, after the first pit stop of the day, weigh yourself. Make this a daily routine and record the numbers; that will make it easier to evaluate the effectiveness of your program later on, in addition to allowing you to see progress on a daily or weekly basis.

WATER AND ENERGY REPLACEMENT FLUIDS

Your body needs lots of water to function effectively as a triathlete, and it fulfills many functions. Most important are its properties as a coolant and as a means to flush waste products from the body. Get in the habit of drinking lots of it right now. Clear urine is an indication that you're properly hydrated, and that should be a consistently monitored guide. If it's yellow, you're not drinking enough on a daily basis. With that in mind, you also want to know how much water you need as an individual in training or racing situations. You need to conduct some experiments now.

Keep an eye out for days of moderate temperature. On one of them, go out for a half-hour run at a medium pace. Before and after that run, you want to weigh yourself—nude, dry, and after urination. The difference in pounds is the amount of water you lost in pints. (If your scale isn't precise enough to register a difference, try hour-long runs instead.)

Conduct this experiment a few times with each one separated by a few days, and you'll come up with an average idea of how much water your body needs. If you average a pound lost in a half-hour run, that means you need 2 pints of water an hour as a basic minimum.

If you live in an area with wide seasonal variations, or compete in vastly different environments, it's probably a good idea to run this experiment whenever there are significant changes in climate. Those who live and race in southern California, for instance, where temperatures are often in the 70s with low humidity year round, will have a more consistent guide than those who live in Michigan.

In the north, the loss of water you experience during spring tests in cool weather may be much less than in the summer, when temperatures and humidity percentages routinely hit the 90s. Your water-use rate can rise substantially in such extreme environments.

Sports drinks or energy replacement fluids seek to deliver muscle fuel and electrolytes to your system in addition to the water it needs. The fuel comes in the form of sugar or carbohydrates and most replacement fluids also include salt and electrolytes. A problem arises when the solution has too high a concentration of constituents other than water. If the balance is wrong, the water your body needs can't be absorbed, so you don't get the water or fuel you need.

In any event, a muscle can store enough fuel to allow it to operate for about two hours of exercise at a moderate intensity. So in events that take you two hours or less to complete, you don't really need replacement fluids or food, but you still need water.

In events lasting longer than two hours, food or replacement fluids are recommended. However, mixing food and replacement fluids can get you into trouble. If you drink nothing but a properly balanced replacement fluid, and also eat, the solution becomes imbalanced in your stomach and the water can't be readily absorbed. You need to add plain water to make the balance correct again. It's OK to drink a replacement fluid and eat, but you have to drink water as well. Or you can drink water and take energy in the form of food (high-carbohydrate snacks—fruit, rice cakes, low-fat granola bars, etc.) and forget about the replacement fluid; just make sure you drink lots of water with that food.

What about electrolytes? In general, your body has all the electrolytes it needs if you eat properly, and you don't need supplementary salts during most of your training and racing. However, very long distances and heat change that equation. If you're working out in the heat for more than six or eight hours, you need those salts in energy replacement drinks. In races of less than four hours, you don't need them; longer than that, and they become an issue.

One final consideration: Sports drinks and foods do not treat all individuals equally. Side aches are tip-offs to drinks or foods that aren't compatible to your system. Experiment with various foods and products during your training so you know which ones work effectively for you. Race day is no time for experiments unless you're willing to take a risk.

WORKOUT INTENSITY

Your heart is your guide when you're talking about your workout intensity. Your maximum heart rate is your benchmark, the number that serves as a fundamental point of reference. Young adults ages 13 to 20 should use 200 beats per minute as their theoretical maximum heart rate. (For persons over age 20, calculate your theoretical maximum heart rate by subtracting your age from 220 for

men and from 226 for women.) Further, we'll assume that your resting heart rate is 70 beats per minute, the average for most people.

Keep in mind that aerobic means "with oxygen," and when you're training at an aerobic rate, it means that the working muscles are getting enough oxygen to supply their needs. When you go "anaerobic" it means you are working so hard that the muscles aren't getting enough oxygen.

Also, determining your heartbeats per minute during training is sometimes difficult. A heart-rate monitor is one solution, or you can stop at regular intervals during training to take your pulse. After a while, you will develop a sense of what paces to swim, ride, or run to approximate the desired heart rate. Finally, a good, but imprecise, rule of thumb: If you can carry on a normal conversation during a workout, you are clearly in the aerobic, low-intensity range. When conversation becomes difficult, you are working at a moderate intensity. And if you can't talk at all, it's probably anaerobic.

KARVONEN TRAINING HEART RATE

To determine your optimal training rate, let's do a little math. First, take the number representing your maximum heart rate (200 for young adults) and subtract your resting heart rate, 70. The difference is 130.

$$200 - 70 = 130$$

Then, multiply 130 by .60 and add your resting heart rate, 70, back into the equation.

$$130 \times .60 = 78 \\ 78 + 70 = 148$$

This number, 148, represents the training heart rate at which you will receive the minimal aerobic benefit.

Now, let's redo the equation to determine the maximum training heart rate. To begin, repeat the first step. Subtract your resting heart rate, 70, from your maximum heart rate, 200. The difference is 130.

$$200 - 70 = 130$$

Then, multiply 130 by .85 and add your resting heart rate back into the equation.

$$130 \times .85 = 110 \\ 110 + 70 = 180$$

The result, 180, represents the level at which you will receive maximum aerobic benefit.

So, what do you do with that information? These two numbers, 148 and 180, give you your heart's training range. To target your ideal level of intensity, a little more math is required. First, subtract 148 from 180.

$$180 - 148 = 32$$

Then divide the result, 32, in half, for a result of 16.

$$32 \div 2 = 16$$

Add 16 to 148 and the result is 164. To achieve moderate-intensity training, then, you'll need to train at a level between 164 and 180 heartbeats per minute. Anything over 181 bpm (beats per minute) is approaching anaerobic, high-intensity training.

The most effective training, with the least risk of injury, is just below 170 bpm for young adults, in the moderate-intensity range. Training in the high-intensity, anaerobic range is desirable for only about 10 percent of your training in each triathlon discipline. Anaerobic training is very effective, but stressful and injury-inducing.

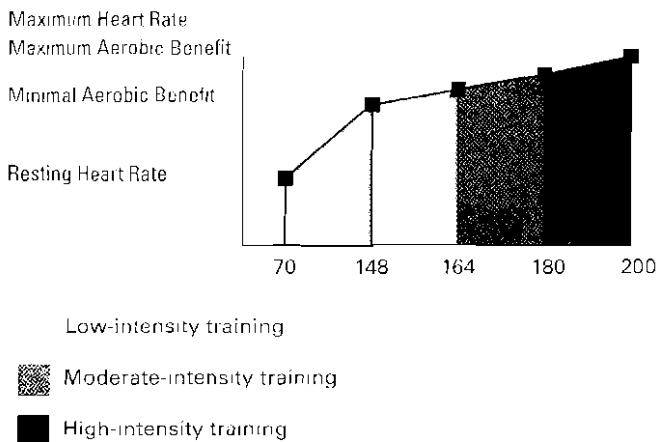

Maximum Heart Rate	200
Maximum Aerobic Benefit	180
Minimal Aerobic Benefit	148
Resting Heart Rate	70

[Editor's note: While there is a strong correlation between high heart rates and anaerobic conditions for most people, it is not as absolute as the above formulas suggest. Some highly trained athletes, for instance, can't reach their theoretical maximum heart rates. Their hearts are so efficient at delivering blood and oxygen with each beat that they can go anaerobic at a lower number of heartbeats than average individuals of the same age. That's why it's called a "theoretical maximum heart rate"; it's a formula based on averages of average people.]

THE HARD/EASY CONCEPT

Athletic or muscular development is based on the overload principle. Ask the body's muscles and systems to do a little more work than they're used to, and then give them time to recover.

Triathletes must juggle workouts for three different sports, though, and it can be difficult fitting everything in the right doses. Complicating things further is the fact that not everyone agrees on the exact meanings of hard and easy.

Elsewhere in these pages, we've divided training rates into three categories: low-, moderate-, and high-intensity exercise. To apply the hard/easy concept, ensure that if you do high-intensity workouts in one sport today, you don't do high-intensity workouts in that sport tomorrow. High-intensity, anaerobic workouts create a great deal of stress on the body's systems that can lead to dramatic improvements; the risks of injury, however, are equally dramatic, and are much greater than for aerobic workouts. Following a day of high-intensity exercise with some sort of rest minimizes the risk of injury or cumulative overtraining fatigue.

The disagreements in applying these principles revolve around what constitutes rest, and how much is necessary for the various muscle groups involved. For instance, since swimming uses mostly upper-body muscle groups, it's generally considered safe to follow a day of high-intensity, anaerobic swim workouts with a day of high-intensity running or cycling. And while everyone would agree that it's foolish to do two consecutive days of high-intensity running, is it really safe to follow one day of such running with a day of high-intensity cycling?

Running and cycling movements depend on different muscles for most of the power generated, but most leg muscles are used to some degree in both activities. So while some triathletes will take a chance doing that hard run today and hard bike tomorrow, others will avoid the inherent risks and play it safe instead. Depending on the individuals involved, either approach may be equally effective. The thing to bear in mind is that one approach has more risks than the other. Typically, serious triathletes will follow a day of high-intensity training in one sport with a day of low-intensity training in that same sport, and no more than a moderate intensity in either of the other two.

Meanwhile, Tri-Fed/USA Medical Committee member, Glenn Town, Ph.D., believes that it's acceptable to follow a day of high-intensity running with a day of high-intensity cycling. But on the day after a high-intensity workout in any one discipline, he never does anything in that same discipline.

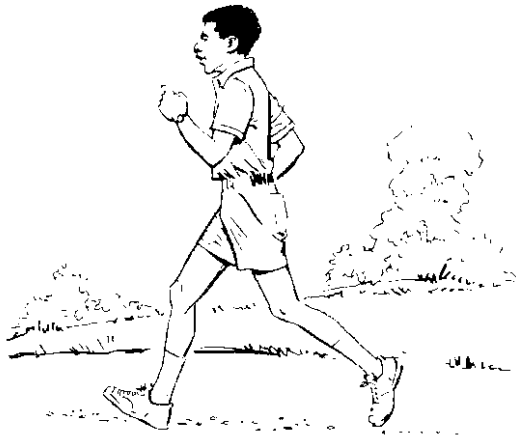

For example, according to his physiological scheme of things, following a day of high-intensity running with a day of slow running has two flaws. The first is that he doesn't believe the slow workout provides any substantial training benefit, and the second is that he feels the running muscles are better served by complete rest.

It's Town's contention that after you've completed early-season training, continued long, slow, distance training is a waste of time unless you're gearing up for something really long such as the Ironman. When you've reached the stage in your training season that you're doing high-intensity interval work, Town believes that the cardiovascular gains possible with low-intensity training are so insubstantial as to be pointless.

Town feels that a triathlete is better served by doing absolutely nothing in a given sport after a high-intensity workout in that sport. He advocates a hard/rest concept.

Whatever you do, as a beginning triathlete you'll want to play it safe. Whether you subscribe to a hard/easy concept or Town's hard/rest concept, just be sure not to engage in two consecutive days of high-intensity training in the same triathlon discipline. That's an absolute!

YOU AND YOUR BIKE

It's easy to get the impression from reading this chapter that you can't be a triathlete without the very latest super duper, high-tech equipment. That's not true. At the elite levels of the sport, much of that equipment is necessary, but the benefits are slim compared to the costs in money and reliability. That stuff may make a difference to the best pros, but for the rest of us, the advantages are much less pronounced.

If you have any kind of 10-speed bicycle in good working condition, you can be a triathlete. If it's a clunker that weighs more than 30 pounds, you'll work 10 or 20 percent harder than with a lightweight bike, but that's no excuse for not being a triathlete.

Assuming you're using the bike you have, make sure that it fits, and that the brake and gear cables are in good condition. Adjust the gears and brakes to work correctly and reliably; ensure that your tires and tubes are in good condition and that the wheels are true (straight). Most bike shops will do all of that for \$50 to \$100, depending on how much has to be replaced. Even better, buy a bike maintenance book. Get to know your bike now and you'll save money and frustration in the long run.

If your bike weighs less than 30 pounds, you may want to consider a set of lightweight wheels for racing only. They are much lighter, and wheel-weight savings enhance performance more than any other component change.

GENERAL EQUIPMENT NEEDS

We've listed below a minimal inventory of equipment you need for your triathlon training program. You need a good, tight, racing swimsuit made of synthetic fabric; they create much less drag than swimming trunks. Swim goggles keep chlorine, salt, or water out of the eyes and help visibility, which is very important in open-water swims. A swim cap will keep hair out of your eyes, and it will also help the body retain warmth in cold water; wear a couple if it's really cold. For triathlons that will take you less than three hours to finish, you may decide to race only in your swimsuit, as many of the pros do.

During training, however, you'll want to wear cycling shorts on the bike. Good models have chamois lining that makes time in the saddle more pleasant, and since the pant legs reach almost to the knee, they offer road-rash protection should you crash. Always wear a hard-shell helmet. As for other cycling wear, a pair of running shoes will do fine if you don't want to buy cycling shoes, but the latter are far superior—steel shanks in the sole minimize stress on the feet. Tight-fitting cycling jerseys look great, and they have lots of pockets, but you don't need one. A close fitting T-shirt is also good; a baggy one will interfere with aerodynamics.

Get a good, sturdy pair of running shoes designed for the heavy stresses of training on the road; you can always buy lightweight racing flats later if you want. Running shorts are self-explanatory. A hat or visor limit annoyance caused by the sun, and sunglasses help protect the eyes from damaging ultraviolet light. You probably have many of these items already. Use what you have and upgrade your equipment as funds become available.

TAPERING AND PEAKING

Tapering and peaking are based on the assumption that your body needs rest from intense training before an important race. In simplest terms, it means you don't engage in any high-intensity, anaerobic workouts in the week before your target event. In general, you should reduce the training distances you reached before that week by half.

You know there are triathletes out there who race every week during the season: tapering and peaking are obviously inapplicable in those cases. If you reduce your training the week before an event, and you race every weekend, you're not getting any quality workouts done. So tapering and peaking is a concept that usually applies to an important, special race. It works best a few times a year, but some triathletes try to peak on a monthly basis during the height of the season.

STRETCHING, WARM-UPS, AND COOL-DOWNS

Stretching helps keep the muscles loose and flexible and lessens the risk of injury. Yet recent studies have demonstrated that people who stretch tend to have more injuries than those who don't. How's that? They're stretching improperly. The mistake many people make is to stretch immediately before or after a workout, and to stretch too far.

The best time to stretch is when the muscles are already warmed up and loose from a day of activity. Never bounce into a stretch or overstretch; initiate a stretch slowly, then back off when it begins to hurt.

Regardless of whether you stretch, get in the habit of completing a warm-up and cool-down before and after workouts. Spend five to 10 minutes slowly getting up to your desired training pace, then begin the real workout. This will lessen the risk of injury; it's especially important before interval workouts.

Do the same after you're done; cooling down for five to 10 minutes will reduce the likelihood of cramps as well as help dissipate the waste products, such as lactic acid, that build up with intense exercise.



Body stretches

Achilles Tendon and Calf Stretches

Standing about 3 feet from a wall, lean forward placing the palms of your hands flat against it. Keeping your back straight and your heels firmly on the floor, slowly bend your elbows. Hold this position for 30 seconds.

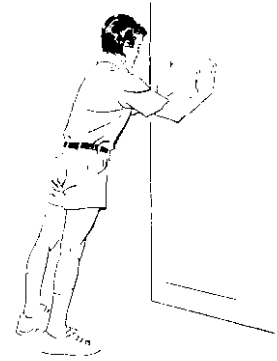

Leg Stretcher

Sit in the same position as in the saddle stretch. Resting your left hand on your left thigh, grasp the inside of your right foot with your right hand. Keeping your back and legs straight, slowly raise your right leg to a 45-degree angle from the floor. Hold position for 30 seconds.

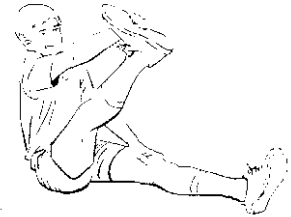

Hurdler's Stretch

Sit on the floor with left leg extended straight ahead. Keep the thigh of the right leg at a right angle to your body with the heel close to your buttocks. Slowly slide your hands down the extended leg and touch your foot. Keeping your leg in the same position, slowly lean back and rest your elbows on the floor. Hold position for 30 seconds and repeat both exercises with the other leg.

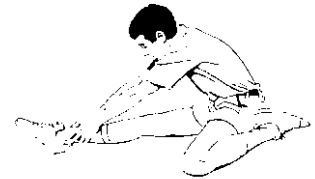

Straddle Stretch

Sit on the floor and spread your legs about twice shoulder width. Slowly lean forward from your waist, sliding your hands along the floor as far forward as you can. Hold position for 30 seconds.



Return to the starting position. Slowly stretch over your right leg, sliding both hands to your right ankle. Try to keep your knee straight and touch your chin to your right knee cap. Hold position for 30 seconds and repeat stretch with left leg.

CYCLING TECHNIQUE

Riding a bike looks simple, and it is for the most part, but there are several techniques to make your cycling much more efficient. The first step is using your cleats effectively. The real purpose is to allow you to pull up with one foot while the other foot and leg are pushing down on the usual power-side of the pedaling stroke. Pulling up with the resting leg brings more muscle groups into play; you're putting that resting leg to work helping the power leg and reserving the energy stored in the muscles that provide the power in the downstroke. You bring new resources into play that you didn't use before, and you're more effectively using the muscles you already depended on to turn the pedals.

At first, you'll have the tendency to think in terms of pushing down with the one leg while pulling up with the other. Ideally, however, you want to think in terms of pedaling in circles—a smooth, continuous circular pedal stroke instead of a choppy up-and-down one. After a while, your muscles will get the message and do it automatically.

Most experienced cyclists pedal at a rate of 80 to 100 revolutions per minute (rpm), and that range should be your goal. Go out for a ride and count your pedal strokes; if you're in a medium gear and you're pedaling 60 or 70 rpm, go to a lower, easier-to-pedal gear, and bring up the speed of your rpm. Then try to stay in that 80-to-100-rpm range by using your gears. If you're in your lowest, easiest gear, and you can't keep up the rpm going up a hill, then get out of the saddle and really use those leg muscles. If you're chugging up that hill with difficulty, however, and you're not in your lowest gear, you're just being foolish.

Lastly, aerodynamics are very important in cycling; \$2,000 disc wheels exist just to cut down wind drag. The most effective thing you can do is to make yourself stay low on the handlebars as much as possible. If you want to get serious, there are bars available that force your body into a more aerodynamic position.

RUNNING TECHNIQUE

Running comes naturally; what is there to learn? Not much, really, and you should run in a way that feels natural to you. But after you've put in some training time on the road, there are easily corrected flaws that plague most people to some degree.

One day when you feel curious or ambitious, go out for a run and look for a long window in which you can see your reflection. Watch yourself run by. If you bounce up and down substantially, you're wasting energy that propels you forward; try to eliminate unnecessary bounce.

It's the same with the swing of your arms; they should move in separate, parallel, vertical planes. If the arms are swinging across the front of your chest, you're wasting energy again, and twisting your body to no purpose. Your upper body should be loose and relaxed, with the arms lightly swinging back and forth, not side to side.

You'll want to eliminate these flaws anyway, just because they impede efficiency. But every one of them can also lead to injury. Bounce increases the stress on the feet and limbs; when your feet cross over, it means that the lower body is twisting itself to accomplish the task and you invite an overuse injury. You get the same result by swinging your arms wildly, which affects your overall body alignment.

SWIMMING TECHNIQUE

The best advice for becoming an efficient swimmer is to either get your own coach or join a master's swimming program. If you won't or can't join a swimming program, there are small improvements you can make on your own.

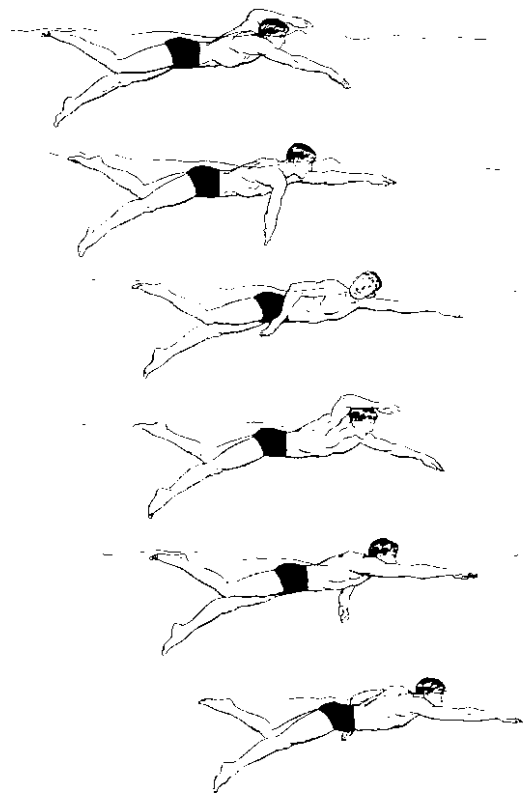

The fastest stroke of all is the American crawl. It is the one usually used in swimming a freestyle race. Short distances can be covered very rapidly.

Assuming you're one of those swimmers who is confident in the water and can flail around the pool and muscle your way through a mile with bad stroke technique, work on your breathing and stroke cycles. Swim with your face in the water, with the water level in the middle of your forehead. Every time you get ready to withdraw your left arm from the water and start a new stroke, turn your head to the left and take a breath. Your face is underwater when you stroke with the right arm, but as you reach the end of the left-arm stroke, you take another breath. After learning how to breathe and stroke like that with a left-side emphasis, try it on the right side (or vice versa).

As to the actual stroke, the hand should cur an S-shaped curve through the water. Your hand should enter the water at a 45-degree angle, with the thumb entering first; the point of entry for the hand should be just outside the line of sight for that side's eye. Bring the hand down at that angle through the water until it crosses under the center line of your torso. Then, pushing out and away, with your little finger leading, bring the arm back up to your side and start over again with the other arm. Remember to keep your elbow high when the hand enters the water: at the time of entry, it should be crooked at a 90-degree angle, not straight.

Try not to roll side to side too much, and stay as flat as possible on top of the water so you create less drag. Don't worry about the kick; that's mostly for stability in long races.

RACE DAY STRATEGY

This is your first attempt to complete a triathlon as a fully prepared, serious athlete, right? Your major priority should be to finish the race and feel good afterward. You can get ambitious and start pushing the pace later on in the season. Right now you want this first triathlon to be an easy, personal victory.

Show up early, at least an hour and a half before the race starts. Find your individual transition area and lay out your gear; make sure everything's there and that it works right. (You should have done that the day before as well.)

Then walk your way through your transitions: from the swim finish to your gear, then out the bike exit. Find out where the bikes come in again, check the route to your area, and then follow the route to the run exit. Check on finish-line details, and know where the toilet facilities are located. Don't miss pre-race meetings, either; that's where organizers announce last-minute changes or explain course peculiarities.

You should have completed registration and transition layout details with 30 to 40 minutes to spare before the race. Start drinking water now; if the swim will take half an hour, and you know that you consume a quart of water an hour, drink at least a pint before you start the race. Anticipate water needs and stay ahead of them!

Go for a five- or 10-minute easy spin on your bike, and then go for an equally short run. If the water is warm, spend the remaining time before the race doing a swim warm-up, and keep those arms doing windmills if you have to leave the water for a start from the shore. If the water's cold, stay out and do simple dry-land, loosening-up exercises.

Once the race starts, go as fast as you can comfortably, probably in a range of moderate intensity. Start the bike slowly, and work up to the desired race pace. Remember—as fast as you can, comfortably!

After you've reached the halfway mark on the run, go as fast as you want. If you run out of gas at that point, you're still close enough to walk in without losing too much time, and unless you really overdid it, there should be no question that you'll finish.

ADDING DISTANCE

First you have to decide on basic goals. Do you want to race faster at short distances or do you want to race at longer distances? Whichever the case, there are general guidelines to help structure your program and keep it safe and productive.

One of the most important factors in training is working up to longer distances gradually. Add no more than 5 percent to your distances for each sport each week. You'll lessen the risks of injury and overtraining, and while it seems like a slow way to gain distance, in eight weeks you'll double what you were doing at the start, and in 12 weeks you can triple it. In 15 weeks you can quadruple what you started with, so adding just 5 percent a week will allow you to reach megamileages at a gradual rate in a reasonable amount of time.

How far you need to train each week, and at what intensities, should be determined by your target triathlon. Whatever the distance you intend to race, during the several weeks leading up to it you should be completing three times that distance in your training every week. That should undoubtedly prepare you to finish any race comfortably.

In addition, in the training weeks before you start the taper, complete at least one workout a week in each sport that is one and a half times longer than the race distance for each sport.

Let's say you plan to compete in an international-distance race in one month. It includes a 1-mile swim, a 25-mile bike ride, and a 6-mile run. The week before the race is for tapering. In each of the three preceding weeks your training is at least triple the distance of your goal race: 3 miles of swimming, 75 of biking, and 18 of running.

Now for the 150 percent formula: One of your swim workouts each week should be 1½ miles long, one of the bike workouts should be at least 37 miles long, and one of the runs should be 9 miles long, all done in a range of moderate intensity, slower than race pace.

As to workout intensities in general, if you're planning to race short distances primarily, most of your training should be in the moderate-intensity range, with some long, slow, distance work, and an equivalent amount of high-intensity work.

If your goal race is an Ironman distance race, your training should emphasize low or moderate intensities and long, slow, distance workouts. It's probably a good idea to completely forget about high-intensity training.

WHEN YOU NEED ASSISTANCE

Tri-Fed/USA is interested in assisting your Varsity team with the sport of triathlon. Membership in Tri Fed/USA will be a personal decision and is not required when seeking assistance.

For assistance, contact:
The Triathlon Federation/USA
P.O. Box 1010
Colorado Springs, CO 80906

Triathlons are a lot of fun and should be enjoyed rather than viewed as "punishment" for the body. Triathletes the world over made up their minds one day to begin training. That must be your first step.

GLOSSARY OF TRIATHLON TERMS

Aid. Any food, drink, equipment, or relief provided by the race organization or allowed by the competitive rules.

Appeal. A competitor's petition seeking review of the decision by a protest committee, rule interpretation, or a disciplinary action adversely affecting the competitor.

Assistance. Any attempt by an unauthorized or unofficial source to help or to stabilize a competitor.

Bike corral. A place for racking and storing bicycles in the transition area, which includes individually assigned areas.

Bi-sport. A sport that combines the skills of two different athletic disciplines in continuum (e.g., running-cycling, running-cycling-running, swimming-running, etc.).

Blocking. When a competitor impedes or obstructs the progress of another participant.

Charge. When one competitor contacts another from the front, rear, or side and hinders the progress of the other competitor.

Competitive rules. The official rules of a triathlon, which govern all events.

Course. A forward line of progress from the start to finish of an event that should be clearly marked and measured to announced specifications.

Disabled. A competitor deemed by race officials as incapable of continuing the competition.

Disqualification. A penalty assessed against a competitor by a referee for a violation of the competitive rules.

Drafting. A type of violation of the cycling-position foul rules committed when a competitor allows the drafting zone of his bicycle to intersect with the drafting zone of another bicycle or that of a motor vehicle.

Drafting zone. A rectangular area 3 bicycle lengths long and 6 feet wide surrounding every bicycle. The drafting zone extends 3 feet to the side of every bicycle. In passing another cyclist, a competitor generally has 15 seconds to pass through the drafting zone. With respect to a motor vehicle, the drafting zone is a rectangular area extending 50 feet to each side of the vehicle and 100 feet behind the vehicle.

Duathlon. A European term for an event consisting of running-cycling-running.

Head referee. The senior and presiding official in any particular event who assesses penalties for rule violations and who otherwise instructs and supervises all other race officials.

Interference. A deliberate block, charge, or abrupt motion that impedes the progress of another competitor.

ITU. The International Triathlon Union is the international governing body for the sport of triathlon. Tri-Fed/USA is a member of the ITU.

Marshal. A race official who is responsible for enforcing the rules by reporting violations to the head referee. A marshal may also include a race monitor who is assigned to direct competitors along the course.

Out-of-bounds. An area not a part of the prescribed race course.

Overtake. In cycling, when the leading edge of the front wheel of one cyclist passes beyond the front wheel of another cyclist.

Pack riding. A type of cycling position foul in which two or more participants work together to improve performance, efficiency, or position by teamwork or other joint conduct. Pack riding will result in disqualification.

Pass. With respect to cycling, the action of entering another competitor's drafting zone and successfully overtaking within 15 seconds.

Penalty. A time penalty or disqualification assessed against a competitor by the head referee for a violation of the competitive rules.

Protest. A petition filed with the head referee within 30 minutes after a competitor finishes a race.

Protest committee. A panel composed of the head referee and at least two judges appointed by the head referee. The head referee serves as chairperson of the protest committee.

Race officials. Race officials include the head referee, any assistant referees, marshals, judges, and the head timer.

Results. The official results of a race including the time and finishing positions of all competitors after penalties have been assessed and protests determined.

Right-of-way. When a competitor has established a lead position and pursues a desired course within the limits of the competitive rules.

Sanction. A permit issued by Tri-Fed/USA to a person or organization to conduct a sanctioned (approved) event.

Transition area. An area or location in which competitors make a transition from one portion of the event to the next and where equipment is stored.

Triathlon. A sport combining any three different athletic disciplines in continuum such as swimming, cycling, and running.

TRI-FED/USA. Triathlon Federation/USA is a California nonprofit public benefit corporation with its principal office in Colorado Springs, Colorado. Tri-Fed/USA is the national governing body for the sport of triathlon and related multisport events in the United States.

Unsportsmanlike conduct. An infraction of the competitive rules that may result in the assessment of a penalty.

ACKNOWLEDGMENTS

The Boy Scouts of America is grateful to the Triathlon Federation/USA for its assistance in developing this chapter. Much of the material used in this pamphlet is adapted from the Tri-Fed/USA publication, *1990 Triathlon Competition Guide*, and is used with permission.

VOLLEYBALL CONTENTS

Background	107
Program Fields of Emphasis	109
Condensed Rules of Volleyball	109
Volleyball Practice	112
Warm-up and Conditioning Exercises	113
Skills Development Drills	114
Scrimmage and Practice Games	115
Coaching League Games	116
Prevention and Care of Injuries	117
Glossary of Volleyball Terms	118

VOLLEYBALL

BACKGROUND



This chapter contains an introduction to the sport to get you started. Information about the playing court, player positions, and condensed rules are outlined to assure that each team member has a basic understanding of the sport.

The chapter goes into depth on the four parts of practice—warm-up and conditioning, skills development, team talk, and practice (scrimmage) games.

Volleyball was invented by William G. Morgan, physical director of the Holyoke, Massachusetts, YMCA, in 1895. Initially called “mintonette,” the game was played by hitting a basketball back and forth with the hands. Later a net was added and players on each side passed the ball across the net.

In 1896 an observer noted that players seemed to be “volleying” the ball over the net, and the name “volleyball” stuck for good.

The first national championship in the United States was played at the Brooklyn Central YMCA in 1922, and with the growth of the sport demanding it, the United States Volleyball Association was founded in 1928.

In 1964, played in more than 80 countries, volleyball for men and women was added to the program of the Olympic Games.

Volleyball is governed in this country by the United States Volleyball Association (USVBA), which is responsible for sanctioning open competition. The USVBA is a member group of the U.S. Olympic Committee and represents the United States as a member of the International Volleyball Federation (FIVB). The USVBA determines the rules of the game in this country and selects the U.S. National, Pan American, and Olympic teams.

Varsity volleyball should be played for fun. The game is easy to play. All that is needed are two teams, a ball, a net, and some flat ground, a beach, or an indoor facility like a gymnasium.

The object of the sport is to propel the ball over the net so that it touches the inbounds ground or floor within the opposing team’s defined court area.

Varsity teams are encouraged to participate in volleyball leagues found in most communities. These leagues may be operated by church associations, park departments, the YMCA, or sports associations.

The basic rules for all are similar. The number of players, court size, and periods of play may vary slightly, depending on your location. Varsity teams participating in these leagues abide by the league rules.

Volleyball is basically a simple game. Two teams composed of an equal number of players try to score more points than their opponents to win the game. A game is

usually 15 points and must be won by a two-point margin. A match usually consists of three games. The team winning two games is the victor.

Some tournaments are played under a time limit. The league sponsoring the tournament sets the time limit for each game. The team with the most points at the end of the time limit is the winner, regardless of the game’s score.

You won’t need a lot of equipment to play volleyball. Shirts, shorts, and sneakers (tennis or deck shoes) are worn by team members. Usually players have distinctively colored shirts that identify their team. Numbers on the shirt could be added, but this is not necessary.

Three types of officials work each game. The referee starts and stops all play and makes final decisions on the rules. The umpire calls violations involving unsportsmanlike play, violations of the centerline, and players out of position when the ball is served. The umpire also authorizes substitutions and time outs, and records time allowed for injury and time between games. The linesmen rule on balls out of bounds.

Each game also has a scorekeeper who keeps the official score throughout the game. Games may be played with only a referee. If so, the referee should be positioned on a raised platform above the top of the net outside the playing area.

When available, the umpire is stationed on the floor, at the net, outside the playing area. Linesmen are stationed on opposite ends and corners of the court outside the playing area.

The game begins with the toss of a coin to determine the team that will serve or have choice side of the court. The winner of the toss usually chooses to serve unless the game is being played outdoors where the wind or sun is an important factor.

Each team takes its position. Three players are in the back half of the court and three are in the front half of the court.

The player in the right back position of the serving team serves the ball from the serving area behind the backline over the net into the opponents’ court. The ball must land on or inside the boundaries and not touch the serving team’s court or the net on the way over. The same person continues to serve until his team commits a foul or makes an error. In both instances his team loses possession of the ball.

Points are scored only by the serving team. No points are scored for “side-out” (loss of ball possession).

After the ball is put into play, it is volleyed back and forth across the net until the ball falls to the floor or is hit out of bounds, or either team commits a foul. Except for the serve, all passes are made by striking the ball. The ball may not be held.

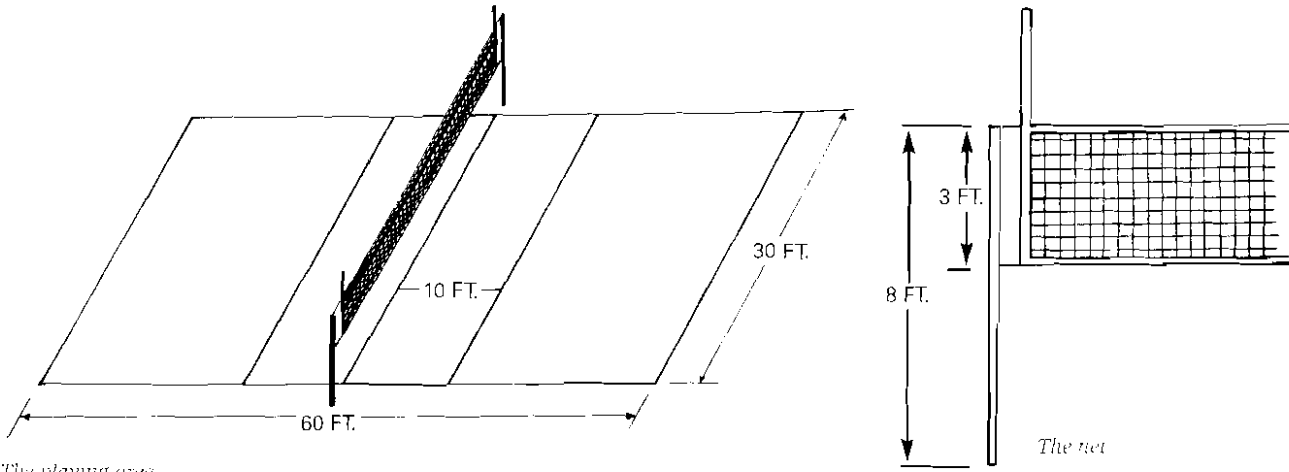

THE PLAYING COURT

Volleyball is played on a rectangular court twice as long as it is wide. Olympic, college, and high school courts are 30 feet wide by 60 feet long bounded by 2-inch-wide lines and divided in the center by a net and a 2-inch-wide centerline. The net is 3 feet wide, 32 to 34 feet long, tightly stretched across the centerline, and mounted 8 feet in height from the net top to the floor.

In each team area a spiking line 2 inches wide is drawn between the sidelines parallel with and 10 feet from the centerline.

Behind each team area a service area is drawn. The service area lies from the team's right sideline left for 10 feet and behind its endline.

PLAYER POSITIONS

There are six named positions in volleyball. They are: right back, center back, left back, left front, center front, and right front.

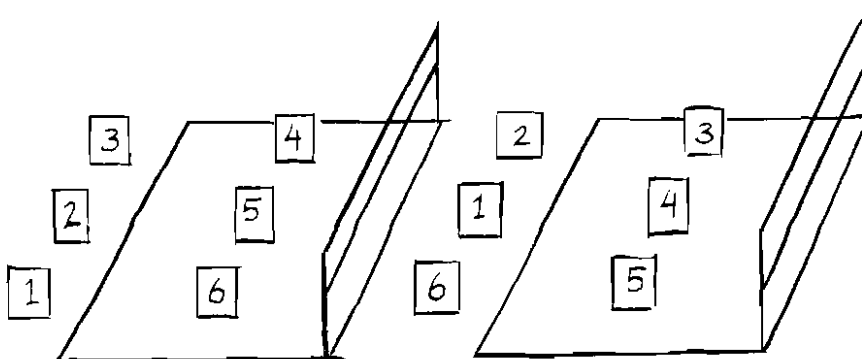
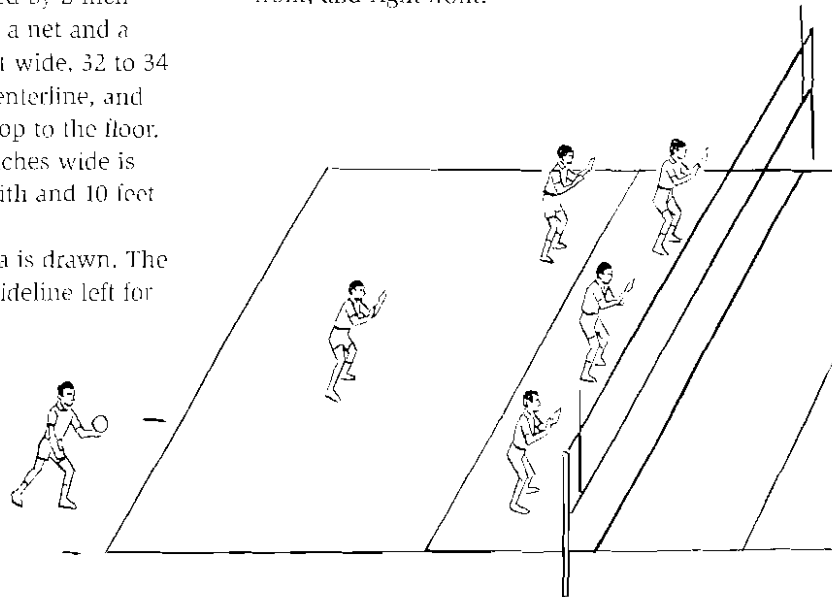

Position of players for service

PROGRAM FIELDS OF EMPHASIS

The following ideas will help you plan a well-rounded program. Program managers carry out these ideas with help from a team committee member.

ADVANCEMENT

- Review each Varsity Scout's advancement status.
- Conduct a merit badge clinic for Athletics.
- Monitor the team advancement chart regularly.

HIGH ADVENTURE/SPORTS

- Program manager outlines or updates the team's annual special high-adventure event (Philmont, Florida Sea Base, etc.).
- Conduct a volleyball activity.

PERSONAL DEVELOPMENT

- Conduct an ethical decision workshop. Use the BSA publication *Youth's Frontier: Making Ethical Decisions* as a guide.
- Visit a military base for a tour. Find out why fitness is vital to our national defense.

SERVICE

- Select a Webelos den and assist the members with activity badges.
- Contact your parks department and adopt a park. Look after the grounds selected for the spring or fall season.

SPECIAL PROGRAMS AND EVENTS

- Invite Order of the Arrow members to a team meeting to tell about the OA program. Have a team Order of the Arrow election.
- Visit a high school or college computer center. Learn how computers are used in sports.

CONDENSED RULES OF VOLLEYBALL

The court—See diagram.

The ball—25 inches to 27 inches in circumference having a leather or rubber case and weighing 9 to 10 ounces; inflated to 5 to 7 pounds per square inch.

Number of players—Teams have an equal number of players, usually six, but can be fewer.

Player equipment—Consists of shirt, shorts, socks, and shoes. Includes knee and elbow guards when playing indoors.

Officials—Referee, umpire, linesmen, scorer. May be played with only a referee.

Time-outs—A team captain or coach may request a time-out when the ball is dead. Time-outs are for 30 seconds. Two time-outs per game are allowed.

Injury—A time-out is allowed for injuries and is not charged to the injured player's team. The referee declares such time by stopping play. The injured player may resume play or a substitute may take his position.

Foreign object—The referee may stop play when a foreign object enters the playing area. A replay is ordered when the object has been removed.

The start of play and service—A coin toss determines the serving team or playing area. The teams change serve and sides at the end of each game of the same match. In a best-two-of-three match during the third game, teams change playing areas after one team has scored eight points or the first time the ball is dead after half the allotted time for the game has elapsed. There is no change in player positions or rotation of service when playing areas are changed.

Position of players—Players' positions for each game are determined prior to the start of the game. Players must remain in that serving order. The lineup may be changed for each new game.

Server—The server must stand within his serving area and may not touch the boundaries of this area at the instant the ball is contacted for the serve.

Other players—When the ball is served, every player must be within his playing area as listed on the lineup. Forwardline players must be in front of backline players at the instant the ball is contacted for the serve.

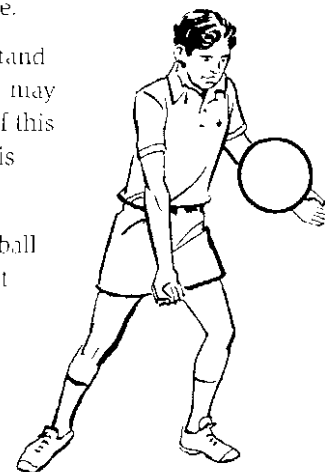

The serve

Positions after service—Following the serve, players may move from their designated positions. A backline player may not "spike" the ball in front of the spiking line from above the net level unless his jump takeoff is behind this line.

Service out-of-turn—Players serving out-of-turn may be called by the scorer, by the opponent's captain, or by the coach. Any points made after out-of-turn service are cancelled and side-out is called. Points scored before the fault is discovered are not cancelled, but players must return to proper position before service begins.

Substitutions—A substitute must report to the scorer before entering the game. He must take the position of the player he is replacing. The original player must return to the same position when reentering the game. A player may enter the game no more than three times. No substitutes may enter the court while the ball is in play. Failure to adhere to the substitution rules may result in loss of points and side-out declared.

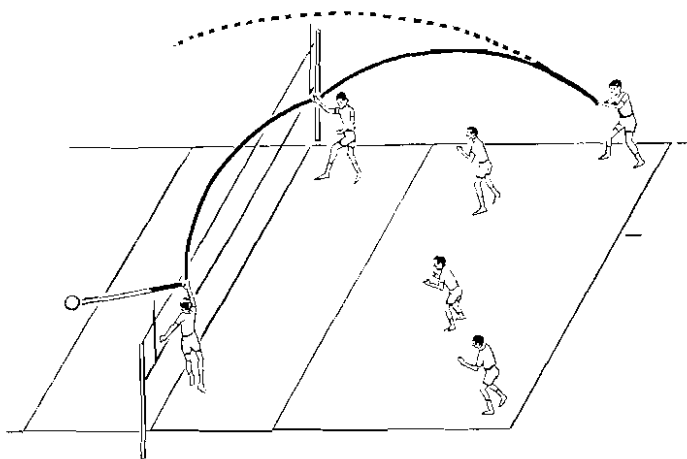

Playing the ball after service

Dead ball—A served ball is dead if it:

- Touches the serving team's floor or a teammate
- Passes under the net, hits the net, or crosses the net outside the boundary lines
- Touches any obstructions, objects, or ceiling before contacting an opponent or the floor of the opponent's area.
- Lands out-of-bounds

Net play—A player may not make contact with any part of the net or its suspension rope (cable) while the ball is in play, nor may a player reach over the net except when following through on a spike or in a block. A blocker may not contact the ball across the net before the opposing hitter does.

Centerline—A player may not go over the centerline. He may touch the line when the ball is in play. He may reach under the net to retrieve a ball in play by his team.

Ball touching the net—A ball may be played after it touches the net when entering the opponents' playing area except when served.

Contacts by players—Successive contacts of the ball may be made by a blocker. He may participate in the next play.

If players contact the ball simultaneously on top of the net and the ball falls on either player's side, it is not considered one of the allowed three hits by his team. Should the ball go out-of-bounds following this simultaneous contact, the player behind the direction of the ball is considered as having touched it last.

Simultaneous contacts of the ball by more than one player of the same team are considered one play.

Successive contacts by a player other than the blocker may not be made except when:

- Simultaneous contact is made by teammates
- Simultaneous contact is made by opponents
- Successive contact is made by a player in one attempt to play a hard-driven spiked ball

Three touches by team—A team may play the ball no more than three times before it crosses the net.

Outside of court—While the ball is in play, a player may go outside the court and may retrieve the ball while outside. He may cross the assumed extension of the centerline, but may not play the ball there.

Scoring—A point is scored by the serving team when its opponent makes an error or commits a foul. There are no points scored on a side-out. The team winning the first two of three games wins the match.

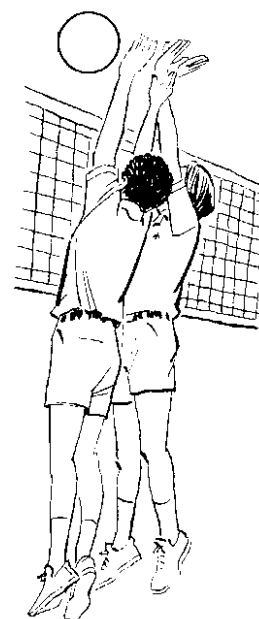

Blocking

COURTESY AND CONDUCT

- No unsportsmanlike conduct is permitted.
- Players, team members, coaches, and managers are not permitted to make derogatory remarks to other players or officials.
- No attempts should be made to influence the decisions of the officials.
- A referee has the authority to warn, declare side-out or point, or disqualify for the game or the match any player, coach, or manager who in the referee's opinion commits any violation of sportsmanship.
- Players, coaches, or managers may not attempt to slow the game unnecessarily.
- The server may not delay serving nor serve too suddenly. He shall allow a reasonable time for opponents to return to their positions following a play.

Fouls—Certain circumstances constitute fouls. Penalty of points or side-out may result if fouls are committed. Double fouls are played over—no penalty. A foul occurs when:

- Player is out of position when the ball is served
- Server puts the ball into play from outside the serving area or serves out of turn
- Player contacts the net while the ball is in play
- Player reaches over the net to play the ball
- Player crosses centerline or commits under-the-net interference while ball is in play
- Player contacts the ball across the centerline extension
- Backline player spikes in front of the spiking line
- Team takes more than allowed time-outs
- Substitute does not report to the scorer
- Substitute enters the game in the wrong position
- Substitute enters the game more than three times
- Member of the team commits unsportsmanlike conduct

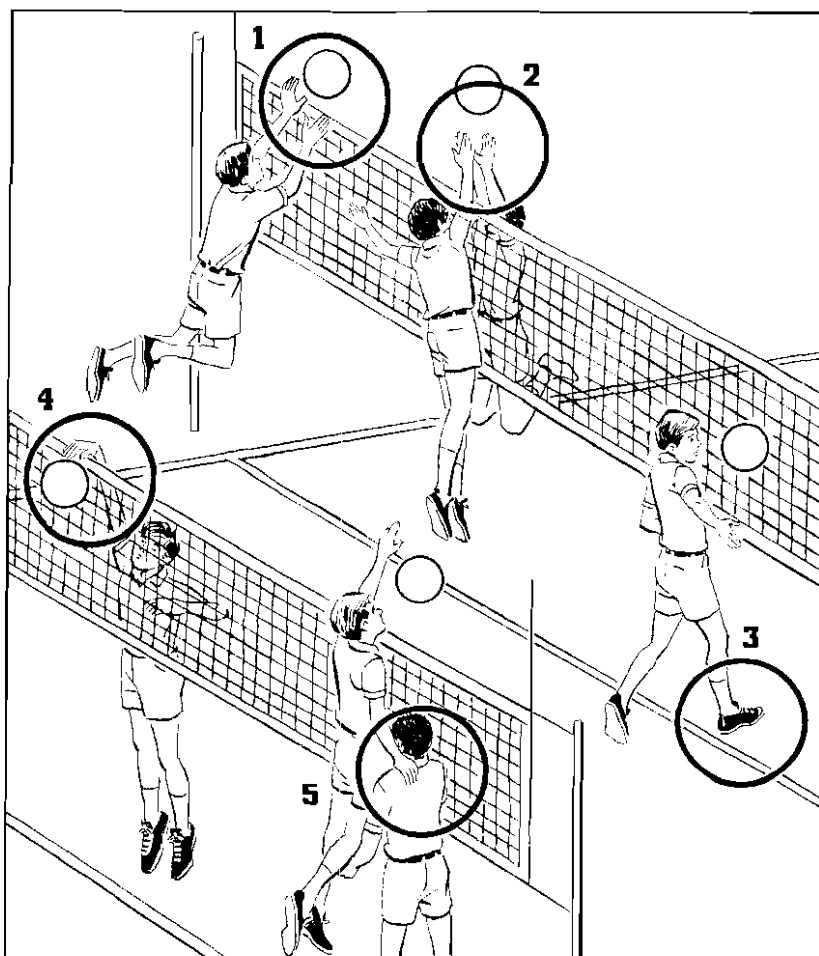

FAULTS

1. A player touches the net or antennas.
2. A player deliberately touches an opponent across the vertical plane of the net.
3. Any part of the player's body touches the opponent's court during play. (The foot may touch the opponent's court if part of it does not cross the center line.)
4. A player reaches over the net or touches the ball above the opponent's court (except when blocking).
5. A ball is returned with the use of a teammate as a support.

Errors—Errors occur when the ball is involved. Points for opponents or side-out for offending team is called when:

- Ball is not clearly hit
- Ball lands out-of-bounds
- Ball is made dead
- Ball is successively contacted by a player (see exceptions)
- Ball is touched more than three times by a team before passing over the net
- Ball touches a player below the waist

Protests—Officials' decisions concerning facts are final and not subject to protest.

- A playing captain, coach, or manager may call to the attention of the referee disagreements with rule interpretations but must do so promptly.
- The referee notes the rule interpretation and notifies the scorer of the situation under which the disagreement occurred.
- A committee authorized to consider rules-related protests makes its decision before the teams involved start their next game.
- If the committee decides in favor of the team making the protest the game is resumed from the point of protest. The exact situation is assumed for the replay.

VOLLEYBALL PRACTICE

Practice sessions are held during the season that the Varsity team is playing volleyball. Practice sessions can occur as part of the troop meeting or a separate meeting. These sessions develop not only the physical side but also the mental side of the Scout.

Many opportunities will occur to blend the sport of volleyball with the game of life. Smart coaches and captains use these opportunities to strengthen the individual Scout as well as the Varsity team. Practice sessions have four parts:

- 1. Warm-up and conditioning exercises.** Simple warm-up exercises, both with and without the ball, allow for loosening the muscles and help in avoiding injuries. Vary the pace and type of exercise. Questions should be asked to stimulate thinking about proper eating habits and the importance of exercise throughout life. This portion of the meeting should take about 10 minutes.
- 2. Skills development drills.** Teaching fundamentals is essential at every level of volleyball. Take time to teach basic skills at every practice session and plan simple drills to reinforce the points.

Players should work both as individuals and in groups of two to four so that no one gets bored or slighted. Use as many balls as possible. Drills should be brief to keep things moving and to save time for scrimmage.
- 3. Team talk.** Make this a regular, normal part of practice. Use it for education and personal development. Team members should be encouraged to talk about such things as rules of the game, principles of team play, positions on the court, team tactics, and concepts of fair play.

These rules, principles, positions, tactics, and concepts apply to everyday life as well as to the sport of volleyball.
- 4. Practice (scrimmage) games.** Several games should be going on at the same time. Team members in groups of three-on-three or four-on-four rotate into all positions so that each player learns to play everywhere on the court.

These practice (scrimmage) games should relate to the skills instruction portion of the meeting.

CALL A TEAM PARENTS' MEETING

After you have had a couple of practice sessions, ask players and their parents to attend a brief meeting. You may want to have the meeting after a practice session or at a special time when most players and parents can attend.

Some ideas for the meeting:

- Introduce team leaders (coaches).
- Discuss practice and game requirements and schedules. Hand out a game schedule.
- Discuss the major points of Varsity sports philosophy and clarify how this philosophy is being implemented.
- Explain the basics of volleyball and suggest some things that help make watching the game more enjoyable.
- Talk about conduct during the game, both on and off the court. Ask parents to help you with this during the game.
- Announce any special family events that are scheduled.

PRACTICE WORK SHEET

Date _____

Time _____

Equipment needed _____

Warm-up (specific exercises and why) _____

Skill development (specific skill; teaching plan; drills to be used) _____

Team talk (specific "strategy" to be used; most effective grouping of players to stimulate discussion)

Practice game (what the players should be most aware of, how to set up teams to accomplish goals)

WARM-UP AND CONDITIONING EXERCISES

Healthy young players are always ready to play the game and rarely look forward to any preliminary "exercises." It is important to avoid making the warm-up drudgery. Interpret its importance in helping get players ready for strenuous exercise.

The warm-up exercises used and the attitude about them will strongly influence the Scouts' lifetime attitudes about exercise. Have Scouts use a volleyball as much as possible for exercises. Select new exercises for each practice and also repeat some that have been done before.

To begin, players position themselves in a circle, in double lines, or in a semicircle facing the leader. Let players take turns choosing and leading exercises. When a player leads, coaches can work closely with individual players or exercise with the players.

Remember: Demonstrate the exercise or game first. Tell why the exercise is important. Have players do the exercise slowly together. Then exercise at regular speed.

WARM-UP ACTIVITIES

1. Lead players for 5 minutes in range-of-motion activity (not forced stretching) using resistive motion in pairs. One player pushes against a partner, with the partner never forcing the first player into a position. Concentrate on ankles, knees, lower back, and shoulders. Almost any common exercises are appropriate.
2. Lead players in a series of short sprints, with jumps, rolls, relays, hops, cartwheels, partner carries, etc. Use the volleyball court for warm-up to develop familiarization. (Five minutes, maximum.)
3. Do some stretching exercises:
 - Slow arm circles—forward, backward
 - Side benders
 - Trunk twisters
 - Toe touching with feet together (knees straight)
 - Toe touching with feet crossed (knees straight)

- Thigh stretch—(a) Lift leg with knee bent. Grasp shin bone and pull knee close to chest. (b) Bend knee and bring heel up toward back side. Grasp ankle and pull toward backside.
 - Calf stretch—(a) Wall push: Heels on floor about 2 feet from wall, knees straight, hands on wall at chest height. Slowly bend elbows and bring chin close to wall and return. (b) Toe and heel rises: Rock slowly up on the toes and down, then back on your heels (lifting toes) and down.
4. Lead players in some easy conditioning exercises, i.e., push-ups, sit-ups, back arches, reverse pelvic curls, etc.
 5. Conduct some warm-up volleyball activities such as these:
 - Play catch with balls across the court
 - Bounce the ball across the court with a hard overhead throw
 - Try a series of block jumps at the net
 - Set the ball back and forth
 - Underhand pass back and forth
 - Serve at a partner, who passes the serve back
 6. Play pepper. This activity requires two players and one ball. One person throws the ball straight up and, using a spiking arm motion, hits the ball in a downward path so that the partner must dig the ball up to the first person, who then hits the ball back down (without catching it and tossing it back up).

PRINCIPLES OF WARM-UP

Concentrate on volleyball game-related activities and dynamic activities, such as running, jumping, rolls, and dives. Teach rolls and dives on soft gym mats.

Explain the advantages of warm-up:

- Increases blood flow to active muscles
- Heats active muscles
- Raises body temperature
- Mirrors game activities
- Fine-tunes the body for hard work
- Focuses concentration on volleyball and fun

SKILLS DEVELOPMENT DRILLS

UNDERHAND PASSING

- The coach faces two players and throws 10 easy balls, five to each player, so that each reaches the player at about hip level. Players pass the ball back to the coach. To increase the difficulty, the coach makes harder tosses that compel the players to move to each side, backward, and forward.
- Each player is given a ball and stands 3 to 6 feet away from a relatively smooth and obstruction-free wall, passing the ball against it.
- Two players stand across from each other, passing the ball back and forth, using the underhand pass. The coach should monitor the length of time the two can keep the ball in the air. At first, place the players 5 feet apart, then increase to 10 feet and then 15 feet.

UNDERHAND PASSING/DIVE AND ROLL

- Players form a single-file line 15 feet from a wall. The coach begins the drill by throwing a ball against the wall with varying degrees of strength and at various angles. The first player in line passes the ball against the wall. The next player passes the rebound. The ball should be kept from touching the floor, thus creating a minimum of tosses by the coach. Each player should be encouraged to use a dive or roll to get the ball if necessary.
- Two players take positions on one side of the court. The coach stands on a solid platform at the net and directs easy and hard tosses at each player. The players must utilize the underhand pass, the dive, and the roll.
- Players take positions on the court, with at least 5 feet of space on either side, and face the coach. The coach points left or right and the players shuffle in the direction of the point. The coach uses a verbal cue to signal the players to roll, dive, block, jump, or approach jump.

OVERHAND PASSING (SETTING)

- The coach tosses the ball so that it travels in an arch and falls above the head of the player. The player moves to catch the ball in the position appropriate for an overhead pass. A check of the position of the hands is made.
- The coach faces the players and tosses the ball five times to each player so that it travels in an arch and falls above the head of the player. The player passes the ball back to the coach.

- The coach tosses a ball to a player who sets to a shagger (a player who returns the ball to the coach). The distance between the player and the shagger should be increased according to individual skill.
- The players form a single-file line facing the coach. The first player in line runs toward the coach and stops at a designated point. The coach tosses the ball toward that point and the player passes the ball to the coach.

OVERHAND PASSING

- Using a basketball goal and backboard, two players take positions at progressively longer distances from the basket, beginning at 5 feet. Each player tosses the ball straight up and sets it toward the goal 10 times, trying to put the ball through the goal.
- The coach tosses the ball to a player, who uses the overhand pass to give the ball to a second player. The second player then overhand passes to a target. The distances between the two players and the target can vary from 5 to 15 feet.

SERVING

- A portion of a wall is assigned to each player. A height on the wall is designated that is comparable to the height of the net. Each player either throws or underhand serves the ball over the designated height from a distance of 4.5 meters.
- A towel is placed on each side of the court as a target. These target positions should be changed frequently. Each player aims for a target with either a throw or underhand serve from the opposite side of the court.
- Players are divided evenly into two teams and placed on opposite sides of the net. From behind the endline, each player serves by a throw or underhand serve to a designated player on the opposite team.
- Assign each player a space on a wall. Determine a height on the wall comparable to the height of the net. Each player practices either the underhand or overhand serve from a distance of 6 meters.

OVERHAND AND UNDERHAND PASSING

- Three players are placed on one side of the court. The coach stands on a platform at the net and tosses the ball easily to the players. The first touch should be an underhand pass directed at one of the other players who in turn overhand passes the ball either over the net or on the same side for a spike. (No spike occurs.)

- The players are divided into teams of two. One player bounces the ball toward a partner, who must either underhand or overhand pass the ball after the first bounce. Each player passes the ball 10 times.
- Players form a single-file line outside the endline. The first player runs into the court. The coach tosses the ball anywhere in the court for the player to practice underhand passing skills.
- Three players take positions on one side of the court. A ball is tossed over the net to the first player, who underhand passes the ball to the second player, who overhand passes to the third player for a spike.

SPIKING

- Players form a single-file line as shown below. The first player in line tosses the ball to a setter, who sets the ball back to the first player at the net for a spike. Enhance the drill by adding blockers and diggers to block or return the spike.

SCRIMMAGE AND PRACTICE GAMES

TOSS BALL

Teams throw the ball three times per side before tossing it over the net. The ball may not bounce. Players catch the ball, throw three times, and return the pass to the opposing team.

SCORE TOGETHER

Players on two teams throw or pass the ball over the net to each other, counting each catch or return pass by each team as one point. The object of the game is to see how many total times players can catch or pass the ball without letting it touch the floor or ground. Team members on both sides chant the score.

BOUND BALL

Players overhand pass the ball directly into the hands of a partner on the same team, wrists cocked and fingers spread on the ball without the palms touching. Players see how many passes can be made without dropping the ball.

FOREARM SCORE

A player uses the forearm pass to return a thrown ball to marked spots on the opposite court. Give each area a value. Players compete against themselves for the highest score.

PLAN AND RUN

Teams of three players pass or throw the ball across the net. When a player catches or passes the ball over the net, he or she runs under the net to the other team.

A point is made for each catch or pass. The objective is to keep the ball going back and forth as long as possible, adding up a total score.

THREE-PLAYER PASS GAME

Two players pass to each other over a net. The third player tries to intercept. The third player plays both courts, moving back and forth under the net.

CIRCLE NUMBER

Each player is given a number. When his or her number is called, the player must perform a task (put hand in air, scratch foot, do a knee bend, etc.) before using a forearm pass. The players stand in a circle. The instructor tosses the ball in the air and calls out the number.

UP AND OVER

Two players stand on the baseline of the volleyball court ready to run into the court. A third player on the opposite side of the net tosses the ball high and midway into the opposing court. To score a point, the first player must complete an underhand pass without sending it over the net. The team receives a second point if the second player manages to volley the ball over the net using the overhand pass.

PRACTICE SPIKE

With a coach tossing the ball at the net, see how many times out of 10 tries each player can hit the ball down in the opposite court without touching the net or crossing the centerline.

BLOCK AND PLAY

Place one player on each side at the net. The coach tosses the ball above them both. Each will try to block the ball into the other's court. Each successful block is counted as one point. Play to seven points.

FULL SCRIMMAGE

Against another Varsity volleyball team, or among team members, play a best-of-three match.

If scoring is slow, place a time limit on the second and third games. Rotate players so that all have opportunities to play.

COACHING LEAGUE GAMES

Coaching volleyball games is a great opportunity to get closer to your team. It's also an important time for the coach to model the kind of behavior you expect from your players.

BEFORE THE MATCH

Start your team in a positive frame of mind.

- Remind them of the basic skills you have been working on in practice.
- Help them remember to think and play as a team.
- Suggest that they not worry about what their opponents might do, but concentrate on what they will do themselves.
- Review the important rules.
- Discuss proper conduct on the bench and during warm-ups.

Have the team do a few warm-up exercises before the game starts.

- Begin with two or three stretching exercises.
- Divide into groups of two and three and practice pass, setup, and serve.

DURING THE MATCH

- There should be very little coaching from the sideline. Coaching is done at practice, not when the game is under way.
- Substitute as often as league rules allow, giving everybody a chance to play.
- When a player leaves the court for a substitute, talk to the player about how he could improve in specific areas.
- Compliment the player on good performance. Give new ideas and suggestions. This is a helpful job for the assistant coach, too.

Be aware of the influence of your own actions on the behavior of players and spectators.

- Never leave the bench except when absolutely necessary. Coaches are not allowed on the court except when given permission by the referee.
- Avoid shouting at officials when you feel they make mistakes (you may want to talk quietly to them at halftime or after the game about specific calls or mistakes).

- Avoid shouting at players on the court—of either team.
- Correct your players in a quiet, constructive tone of voice off the court.
- Help keep players cool when they lose their temper by first keeping yourself cool.

BETWEEN GAMES

Quietly review the improvements that players should make in the next game of the match.

- Avoid haranguing players or intimidating them.
- Be cool and helpful, and keep your directions simple.
- Avoid sarcastic or negative comments about members of your team, the other team, or officials.

AFTER THE MATCH

Encourage your players to congratulate the other team. Have a friendly talk with the other coach or the officials. Bring your team together. Allow players to cool down with plenty of water and juice. Have everybody sit down and briefly discuss the game by asking question such as these:

- What went well for the team today?
- Which players on both teams really tried hard?
- Did we have a good attitude toward the other team?
- What can we do better next time?
- What do we need to work on in practice?

You will think of many other questions to ask. The important thing is to stimulate the thinking of your players and let them talk to you and to each other.

Try not to lecture or preach. You can support the statements players make that get your own feelings across. Guide the discussion and make it more than just a one-way communication from you to the team.

Wrap it all up by complimenting the team on a good effort and reminding them of the next practice or game day, time, and location.

PREVENTION AND CARE OF INJURIES

Safety awareness is as important to Varsity volleyball as learning the skills of the sport. All instruction and coaching should include appropriate safety measures, and it is always the responsibility of the coach to supervise the preparation of athletes for competition so that the likelihood of injury is minimized.

Varsity volleyball is as safe as the environment established by adult leadership for the sport. Although injuries sometimes occur, coaches should take all necessary precautions to help prevent accidents, and be prepared to respond when they do occur.

Coaches are responsible for both prevention and care of injuries, but the emphasis for everyone must be on prevention of injury and safe, accident free play.

COACHING SUGGESTIONS TO HELP PREVENT INJURY

Coaching styles have much to do with establishing a safe environment for players. Be creative and flexible, but be prepared and well-organized for practice sessions and games. Design drills to meet the special needs of each player and the team.

Follow the practice outline suggested earlier in this chapter. Be sure to include all four segments of practice time, including warm-ups, drills, team talk, and games.

Try to actively involve all of your players throughout practice with a minimum of sitting, standing, and waiting in line. Provide as many opportunities as possible for each player to pass, set, and serve the volleyball.

Plan instruction and competition by taking into account individual differences in skill and experience. Try to teach skills in their proper progression.

Players will play and act in games in a direct relationship to the way they have been coached in practice sessions. The more gamelike situations created during practice, the better prepared athletes will be for games.

Even when coaches emphasize prevention of injuries through proper warmup, conditioning, supervision, and education, from time to time injuries do occur and first aid must be provided.

Be prepared to respond immediately with appropriate first aid procedures. Never move an injured player if you are in doubt, and never attempt treatment that goes beyond your own training and experience. Your duty is never to provide treatment, but to provide immediate first aid to the injured player.

Recognition of serious injury is the primary responsibility of the coach and must be followed by appropriate treatment by trained medical personnel.

Never send an injured player back into practice or game.

Injury	Suggested First Aid
Muscle pulls, sprains, and bruises	Use ice pack immediately to reduce swelling. Speed of application is essential.
Small cuts	Apply pressure to reduce bleeding. Wash with antiseptic solution and apply sterile dressing if necessary.
Nosebleed	Have player pinch nostrils and hold until bleeding stops. Apply ice pack.
Foreign body in eye	Pull upper lid down, holding eyelash. Wash out with eye-cleaning solution.
Fainting or loss of wind	Rest in cool place. Try to relax player and slow down breathing.
Scrapes and burrs	Wash with cleansing solution. If necessary, cover with gauze.
Elbow or knee injuries; jammed finger or toe	Elevate area and apply ice pack. Refer to physician if pain persists.
Back or neck injury	Keep the player calm. Do not allow the player to move or sit up if pain is severe. If pain is slight, apply ice pack.

Remember: Never send a hurt player back into practice or a game. First aid is the immediate handling of athletic injuries. Refer a hurt player to the family physician for followup treatment if pain persists.

GLOSSARY OF VOLLEYBALL TERMS

Ace. A point scored as the direct result of the serve.

Backing up. A planned system of assisting the player who assumes the responsibility of making the initial contact with the ball.

Ball in play. The ball is in play from the time it is served until it becomes a dead ball.

Block. A defensive play by one or more players who attempt to intercept a ball at the point where it crosses the net by returning it immediately to the spiker's court or deflecting it so that it can be played by a teammate.

Bye. A position usually given to a seeded team in a tournament when there are an uneven number of teams entered so that the seeded team advances to the next round without playing.

Change of pace. A spiked or served ball hit at other than usual speed.

Cover. To be responsible for a certain area of the court; also to back up a teammate who is hitting or blocking the ball.

Cross-set. A long set directed to a spiker that travels parallel with the net and in front of the player to his natural-hand side.

Dead ball. A ball not in play, usually after a point is scored or a side-out is declared.

Defense. A team is on defense whenever the ball is in play and controlled by the opponents.

Dig (or save). A contact of the ball below the waist level with a solid surface formed by the forearms or the heels of the hands. Primarily, the dig is used to recover a hard-driven spike or other offensive shot. Other uses of the dig are in net recovery situations.

Dink. A faked spike in which the attacking player merely taps the ball down on the opposite side of the net or over the outstretched hands of the waiting blockers.

Double foul. The act of two or more players on opposing teams committing a foul at the same time.

Double hit. The act of a player who hits the ball twice in succession.

Error. Misplay that may result in a point for the opponent or a side-out.

Fake. A deceptive movement by a player to confuse or throw off the opposition.

Fake spike. Seeming motion of spiking the ball with an abrupt change to another type of shot such as a dink.

Follow-through. Movement of the arms, hands, or even the body after hitting the ball.

Foot foul. The act of stepping into the court before hitting the ball while serving. Also stepping over the centerline.

Foul. Rule infraction.

Held ball. A ball that comes to rest momentarily in the hands, arms, or any other part of the body. The ball must be cleanly hit.

Kill. Same as a spike, except a point or side-out is earned because the defense could not handle the spike.

Match. An official match consists of the best two of three games (or three of five games).

Multiple block. An attempt by two or more players to intercept a ball at the net.

Offense. A team is on offense when it controls the ball.

Out-of-bounds. Outside the boundary lines of the court.

Pass. The initial contact of the ball by a team within its own court. The object of the pass is to send the ball to a player on the frontline to be set up for the waiting spiker.

Patterns. A basic framework within which the team organizes its system of offensive and defensive strategy (such as positions on the court).

Point. A unit of scoring.

Position. Area of the court occupied by a player. When a ball is served, each player must be in his respective position in rotation order.

Receiver. The first player to receive a ball, usually a serve, played over the net by the opposing team.

Referee. Official of the game, usually stationed at the net, outside and above the court.

Rotation. The movement of the players during the game. Each player moves one position clockwise when his team receives the ball for service.

Service. The act of putting the ball into play.

Setup. Usually the second contact of the ball by a team within its own court. The objective of the setup is to direct the ball to the spiker, using the overhead and reverse chest pass skills.

Side-out. When a team fails to score or loses the right to serve.

Spiking. The act of hitting the ball downward with great force, usually from the top of a jump, into the opponents' court. The objective of the spike is to direct the ball with such power or placement that the opponents cannot return it.

Sticky. A term applied to a held ball even if it's a slight hold.

Switch. The movement of players to more advantageous positions after the ball has been served.

Throw. To actually catch and throw the ball, which is an illegal play; a ball not cleanly hit.

Tip. A hit made to an area not covered by players, usually just over the hands of the blockers.

Volley. The basic skill of the game, in which the ball is contacted by the hands and propelled forward and upward. Also, the continuous action in a game until the ball becomes dead.

ACKNOWLEDGMENTS

Much of the material in this chapter is adapted from the *Y Soccer Coaches Manual* and is used with permission of the Young Men's Christian Association of the U.S.A.

WATERSKIING CONTENTS

Background	121
Program Fields of Emphasis	123
Waterskiing Equipment	124
Waterskiing Signals	128
Basic Skills	129
Competitive Waterskiing	136
Warm-up and Conditioning Exercises	140
Waterskiing Practice	141
Care and Prevention of Injuries	141

WATERSKIING

BACKGROUND



Waterskiing and wakeboarding are exciting, challenging sports. Whether you're learning something new or improving your current skill level, these activities can be both fun and competitive.

Recreational waterskiing challenges the water-skier to get up quicker and smoother, drop one ski and slalom, or jump the wake of the boat. In competition, the water-skier competes for speed on buoy runs or by executing a series of maneuvers or "tricks."

Like any sport, much of the real enjoyment in water-skiing and wakeboarding comes from improvement. The key to improvement is having a qualified instructor. The Varsity team should locate the best consultant available for this activity.

Varsity team members and adult leaders participating in this waterskiing activity must complete the BSA Swimmer's Test. They also must know and agree to follow the Water-Skier's Safety Code.

BSA Swimmer Test

Jump feetfirst into water over the head in depth, level off, and begin swimming. Swim 75 yards in a strong manner using one or more of the following strokes: side-stroke, breaststroke, trudgen, or crawl; then swim 25 yards using an easy, resting backstroke. The 100 yards must be completed in one swim without stops and must include at least one sharp turn. After completing the swim, rest by floating.

WATER-SKIERS SAFETY CODE

Safety is the key to enjoying waterskiing. Understand and live up to the Water-Skier's Safety Code:

- Always learn to water ski by taking instructions from a good water-ski instructor or advanced skier.
 - Always wear a personal flotation device (PFD) when skiing. A PFD is as much a part of the skier's equipment as are a boat and skis. Before entering the water, make sure your PFD is adjusted correctly for safety, comfort, and freedom of movement. Always make sure your PFD is in good and serviceable condition.
 - Always look ahead and know where you are going at all times.
 - Always stay away from solid objects such as docks, boats, and stumps.
 - Always be courteous and stay a reasonable distance from other skiers, boats, and swimmers.
 - Always run parallel to shore and come in slowly when landing.
 - Always learn new maneuvers progressively.
 - Always have an extra person in the boat to watch the skier.
 - Always signal that you are all right after a fall by clasping your hands overhead or waving to notify the driver and observer.
 - Always hold up a ski while waiting in the water in a well-traveled boating area.
 - Always check your equipment for dangerous, sharp, or protruding objects (wing nuts, loose runners, and slivers)
 - Never ski in shallow water or in an area where you do not know the depth. Minimum safe depth is 5 feet or your height, whichever is greater.
 - Never put any part of your body through the bridle or wrap the rope around any part of your body.
 - Never yell "Hit it!" or "Go boat!" until the rope is tight and the tips of your skis are up.
 - Never ski to the point of exhaustion.
 - Never ski at night.
 - Never ski directly ahead of another boat.
 - Never ski double with different lengths of rope.
 - Never attempt fast landings directly toward shore.
 - Never jump from the boat while it is moving.
 - Never climb into the boat or approach the stern of the boat while the motor is running. Always use a stern platform or ladder when climbing into the boat.
- Be particularly wary of shallow water. The water may look deep enough to ski in, but, if your skis hit bottom, your feet will stop suddenly as the rest of you continues forward at high speed. These severe forward falls can cause injuries ranging from painful sand burns to broken bones. Both the skier and the boat driver should familiarize themselves well beforehand with any waters they plan to use for skiing.



The BSA Safety Afloat guidelines were developed to promote boating and boating safety and to set standards for safe activity afloat. The guidelines apply to all motorboating

and water-skiing activities. Every Scout boater should study and understand the nine points of the BSA Safety Afloat plan.

QUALIFIED SUPERVISION

All activity afloat must be supervised by a mature and conscientious adult age 21 or older who understands and knowingly accepts responsibility for the well-being and safety of the children in his or her care, who is experienced and qualified in the particular watercraft skills and equipment involved in the activity, and who is committed to compliance with the nine points of BSA Safety Afloat. One such supervisor is required for each 10 people, with a minimum of two adults for any one group. At least one supervisor must be age 21 or older, and the remaining supervisors must be age 18 or older. All supervisors must complete BSA Safety Afloat and Safe Swim Defense training and rescue training for the type of watercraft to be used in the activity, and at least one must be trained in CPR. It is strongly recommended that all units have at least one adult or older youth member currently certified as a BSA Lifeguard to assist in the planning and conducting of all activity afloat.

PHYSICAL FITNESS

All persons must present evidence of fitness by a complete health history from a health-care provider, parent, or legal guardian. Adjust all supervision, discipline, and protection to anticipate any risks associated with individual health conditions. In the event of any significant health conditions, a medical evaluation by a physician should be required by the adult leader.

SWIMMING ABILITY

A person who has not been classified as a "swimmer" may ride as a passenger in a rowboat or motorboat with an adult swimmer, or in a canoe, raft, or sailboat with an adult who is certified as a lifeguard or a lifesaver by a recognized agency. In all other circumstances, the person must be a swimmer to participate in an activity afloat. Swimmers must pass this test:

Jump feetfirst into water over your head in depth. Level off, and swim 75 yards in a strong manner, using one or more of the following strokes: side-stroke, breaststroke, trudgen, or crawl; then swim

25 yards using an easy, resting backstroke. The 100 yards must be completed in one swim without stops and must include at least one sharp turn. After completing the swim, rest by floating.

PERSONAL FLOTATION EQUIPMENT

Properly fitted U.S. Coast Guard-approved personal flotation devices (PFDs) must be worn by all persons engaged in activity on the open water (rowing, canoeing, sailing, boardsailing, motorboating, waterskiing, rafting, tubing, kayaking, and surfboarding). Type II and III PFDs are recommended.

BUDDY SYSTEM

All activity afloat necessitates using the buddy system. Not only must every individual have a buddy, but every craft should have a buddy boat when on the water.

SKILL PROFICIENCY

All participants in activity afloat must be trained and experienced in watercraft handling skills, safety, and emergency procedures. (a) For unit activity on white water, all participants must complete special training by a BSA Aquatics Instructor or qualified whitewater specialist. (b) Powerboat operators must be able to meet requirements for the Motorboating merit badge or equivalent. (c) Except for whitewater and powerboat operation as noted above, either a minimum of three hours' training and supervised practice or meeting requirements for "basic handling tests" is required for all float trips or open-water excursions using unpowered craft.

PLANNING

FLOAT PLAN

Obtain current maps and information about the waterway to be traveled. Know exactly where the unit will "put in" and "pull out" and what course will be followed. Travel time should be estimated generously. Review the plan with others who have traveled the course recently.

LOCAL RULES

Determine which state and local regulations are applicable, and follow them. Get written permission to use or cross private property.

NOTIFICATION

Provide the float plan to parents of participants and a member of the unit committee. File the float plan with the local council service center when traveling on running water. Check in with all those who should be notified when returning.

WEATHER

Check the weather forecast just before setting out, and keep an alert weather eye. Bring all craft ashore when rough weather threatens.

CONTINGENCIES

Planning must identify possible emergencies and other circumstances that could force a change of plans. Appropriate alternative plans must be developed for each.

EQUIPMENT

All equipment must be suited to the craft, to water conditions, and to the individual; must be in good repair; and must satisfy all state and federal requirements. Spare equipment or repair materials must be carried. Appropriate rescue equipment must be available for immediate use.

DISCIPLINE

All participants should know, understand, and respect the rules and procedures for safe unit activity afloat. The applicable rules should be presented and learned prior to the outing, and should be reviewed for all participants at the water's edge just before the activity begins. When Scouts know and understand the reasons for the rules, they will observe them. When fairly and impartially applied, rules do not interfere with the fun. Rules for safety, plus common sense and good judgment, keep the fun from being interrupted by tragedy.

Note: For cruising vessels (excluding rowboats, canoes, kayaks, and rafts, but including sailboats and powerboats greater than 20 feet long) used in adult-supervised unit activities by a chartered Sea Scouting ship specializing in watercraft operations, or used in adult-supervised program activity in connection with any high-adventure program or other activity under the direct sponsorship and control of the National Council, the standards and procedures in the *Sea Exploring Manual*, No. 33239A, may be substituted for the Safety Afloat standards.

PROGRAM FIELDS OF EMPHASIS

The following ideas will help you plan a well-rounded program. Program managers carry out these ideas with help from a team committee member.

ADVANCEMENT

- Review each Varsity Scout's advancement status.
- Conduct a Waterskiing merit badge clinic.
- Monitor the team advancement chart regularly.

HIGH ADVENTURE/SPORTS

- Program manager outlines or updates the team's annual special high-adventure event (Philmont, Florida Sea Base, etc.).
- Conduct a waterskiing activity.

PERSONAL DEVELOPMENT

- Visit a law enforcement agency that monitors waterways in the community. Learn about careers available in that agency.
- Plan and carry out a fitness program that concentrates on the muscle groups most used in waterskiing.

SERVICE

- Conduct motorboat rides for a senior citizen group.
- Conduct a water-skier's safety session for a Boy Scout troop.
- Encourage individual team members to keep a record of Good Turns they do for a one-week period. Then lead a discussion of their list on the differences between Good Turns and expected responsibilities.

SPECIAL PROGRAMS AND EVENTS

- Visit a boat dealer. Ask the owner or the sales manager to explain the differences between fishing, skiing, and pleasure boats.
- Invite a qualified person to present a session on the care of and preventative maintenance for a family motorboat.
- Conduct an orienteering meet that requires the use of motorboats.

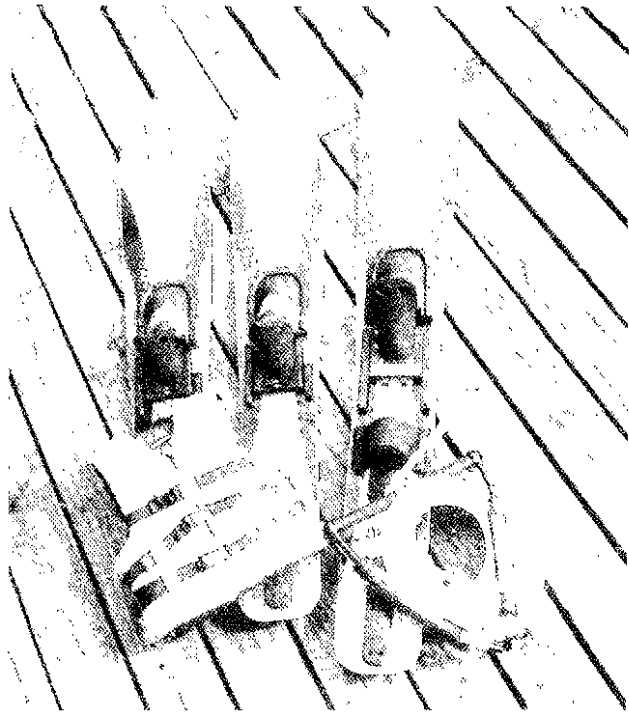

Basic equipment for a water skier; choice of skis, PFD, and tow rope

WATERSKIING EQUIPMENT

Waterskiing equipment consists of water skis, a tow-line, personal flotation devices (PFDs), exposure suits, and a motorboat.

WATER SKIS

There are three basic types of water skis: double, single slalom, and trick. With the exception of the trick ski, a stabilizer fin is found on the bottom of the ski. The type of skis used is not particularly important. You would not use the trick skis or the slalom ski for ordinary skiing, but beyond that the choice of skis is not a major consideration.

Larger skis plane faster at beginner speeds, but the greater buoyancy may make them difficult to handle in starting positions. Small, lightweight skiers should not attempt to ski on oversized skis, and heavy skiers should not use undersized skis.

Generally, the best rule of thumb in selecting skis is to base the decision on the water-skier's weight: that is, small, lightweight skiers should not use oversized skis and heavy skiers should not use undersized skis. Larger skis plane faster at initial speeds, but their greater buoyancy may make them difficult to handle in starting positions.

Skis are fastened to the feet with binders. Some binders are fixed; others are adjustable. Properly sized or adjusted binders are crucial to good waterskiing. When properly adjusted, the fit of the binder should feel similar to a sneaker or tennis shoe, laced up snugly. Make sure the skis, binders, and the feet are wet when adjustments are made. A ski that feels right dry will be too loose when wet.



1. Hold binding to one side



2. Raise heel to grab binding



3. Adjust to proper fit

To fit a ski, hold down the heel binding to one side. Slide your foot into the front binding as far as it will go. Raise your heel so that you can grab the heel binding, then pull it up over your heel. Make certain your heel is firmly in place and that the binder gives you good support. If the ski has fixed bindings that are too large (or if adjustable skis are too loose at their tightest), you can try wearing a pair of heavy socks or liners, which will provide more friction and a snugger fit.

TOWLINE

Towline is another term for rope. Most water-skiers prefer the multicolored towlines made of polyethylene or polypropylene because of their visibility and their ability to float.

The towline is attached to an eye bolt or harness with a swivel located near the center and to the rear of the motorboat. Water-skiers should avoid attaching the towline to the boat cleats; they are made for tying up, not for pulling skiers. A center post with bail and quick release is ideal and is usually included on boats specifically designed for waterskiing.

The other end of the towline has a handle for the water-skier. Most water-skiers use a towline with a single handle. The length of the towline will vary depending on the type of waterskiing being done, but the standard length of a towline is 75 feet. For beginners, the instructor will recommend the appropriate length.



The correct towline grip

TOWLINE GRIP

When waterskiing on two skis, the towline is gripped with both hands, with the knuckles up. When skiing on one ski, the towline is held with both hands, in a baseball grip. Regardless of the grip used, the skier releases the grip when he falls.

PERSONAL FLOTATION DEVICES

Boy Scouts of America policy requires that U.S. Coast Guard-approved personal flotation devices (PFDs) be worn properly by all persons engaged in activity on the open water. Waterskiing is no exception. Before you even fit a ski, learn about the different types of PFDs and their uses, how to put on a PFD, and how to check a PFD for proper fit.

The U.S. Coast Guard has identified five types of PFDs.

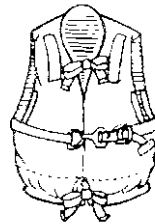

Type I—an approved device designed to turn an unconscious person in the water from a face-down position to a vertical or slightly backward position and to have more than 20 pounds of buoyancy. The device will maintain a vertical or slightly backward position and therefore greatly increase chances for survival. This is the most effective PFD in rough water or remote environments.

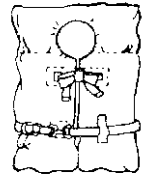

Type II—an approved device that may turn an unconscious person in the water from a face-down position to a vertical or slightly backward position. The device must have a minimum of 15½ pounds of buoyancy; it is recommended for closer, inshore cruising and is acceptable for all size boats.

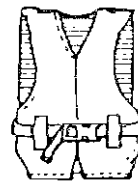

Type III—an approved device designed to keep a conscious person in a vertical or slightly backward position; it has at least 15½ pounds of buoyancy. While it has the same buoyancy as Type II, the Type III device has less turning ability.

This makes it a comfortable design for water activities such as waterskiing. Recommended for in-water sports and close, inshore operation on lakes and ponds, the Type III is acceptable for all size boats.

Type IV—an approved device designed to be thrown to a person in the water but not worn. It is designed to have at least 16½ pounds of buoyancy.

Acceptable for boats less than 16 feet long, for canoes and kayaks, and as a throwable device for boats 16 feet or longer, the Type IV PFD must be in good serviceable condition and immediately available. Buoyant cushions and ring buoys are typical of this type of PFD.

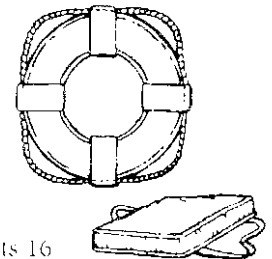

Type V—special-purpose PFDs, including work vests and deck suits. These items have some internal buoyancy and are inflatable to provide additional flotation.

Types II and III are acceptable for most Scouting aquatics activities. Heavy, stuffed PFDs are not recommended for waterskiing since they tend to restrict a skier's movements. A zip-up, belted, plastic cell-filled Type III PFD vest is comfortable and won't interfere with movement. Life belts or ski belts are not permitted. Every skill and maneuver discussed in this chapter can and

must be done while wearing a PFD. A light, foam-type jacket specially designed for waterskiing is acceptable if it is classified as a Type II or Type III PFD.

A typical Type III PFD vest should be worn with the label on the inside. Belt straps should be adjusted so they fit snugly at or just above the waist, in the loops provided. A second buckle or tie strap must be used just below the collar line, unless there is a strong zipper that will secure the top front of the PFD.

Proper care and storage of PFDs is essential. Dry all PFDs off the ground and under cover. Drying in direct sun will cause the fabric to fade and wear out quickly. Buckles must be maintained and repaired as needed. All labels should be readable. If the flotation material or fabric is damaged, the PFD should be thrown away and replaced. Remember that PFDs are not to be used as seat cushions or kneeling pads.

EXPOSURE SUITS

Exposure suits are worn to reduce heat loss in the body. Exposure suits have been worn by underwater divers for many years. There are three basic styles of exposure suits, each with its own characteristics and amount of exposure protection: the body suit, the wet suit, and the dry suit.

BODY SUIT

Body suits are made of spandex or nylon. These are worn when minimum temperature exposure protection is needed.



The body suit is one of three basic styles of exposure suits.

WET SUIT

Wet suits are made of closed-cell neoprene foam. They get their name because a person gets wet while wearing them. Water enters the suit through the wrist, ankle, and neck area of the suit. Once inside, the water is trapped and warmed by body heat. By having a snug fit, the water remains at about the same temperature as the body and serves as insulation. The wet suit comes in many patterns and thicknesses.

DRY SUIT

Dry suits provide insulation by keeping the body dry. These suits are used when temperatures are below 50

degrees. By keeping the air around the body dry, less body heat is used. Water-skiers rarely use dry suits.

MOTORBOAT

Several factors should be considered when choosing a motorboat for waterskiing. First, the boat should have either an inboard or an outboard motor capable of pulling the skier at a speed of at least 25 miles per hour. This power will permit pulling a beginning skier and an instructor at a speed somewhat slower.

The boat must have positive steering. Solid cable steering is preferred. If pulley cables are used, make sure there is no free play in the steering system.

A wide-angle rearview mirror is required by law in most states. This mirror allows the driver of the boat to keep an eye on the skier while driving. Additionally, there should be a safety observer in the boat. This person relays messages from the skier to the driver and manages the towline.

If the ski boat does not have a stern platform just above the water for skier use, then a ladder device must be available. A ladder or platform is essential, for very few beginner skiers can climb over the side of the boat after an exhausting ski practice without injury or substantial assistance.

SAFE BOAT OPERATION

A boat driver has a lot of fun behind the wheel, but a good boat driver never forgets that he or she is not driving for personal pleasure. The boat is operated solely for the benefit and safety of the skier.

A good driver keeps the boat speed even, takes off smoothly, steers a straight course, and rounds curves to make the skiing easier.

A motor's propellers can give a person a bad cut even when in neutral and at idling speeds. A driver, therefore, should never start the motor when anyone is in the water near the stern of the boat.

The boat driver, in addition to providing the skier with a safe ride, should try to give the skier the best possible water conditions. Rough water caused by wind can be avoided by seeking the shore protected from the wind and driving a course that reduces unnecessary boat wake to a minimum. This is accomplished by driving back through the wake just created after each turn.

Where rough water is not a problem, the driver should steer in a wide oval pattern to avoid pulling the skier through the boat wake. Using a "dog bone" turn when reversing direction helps reduce the effect of the boat wake on the skier.

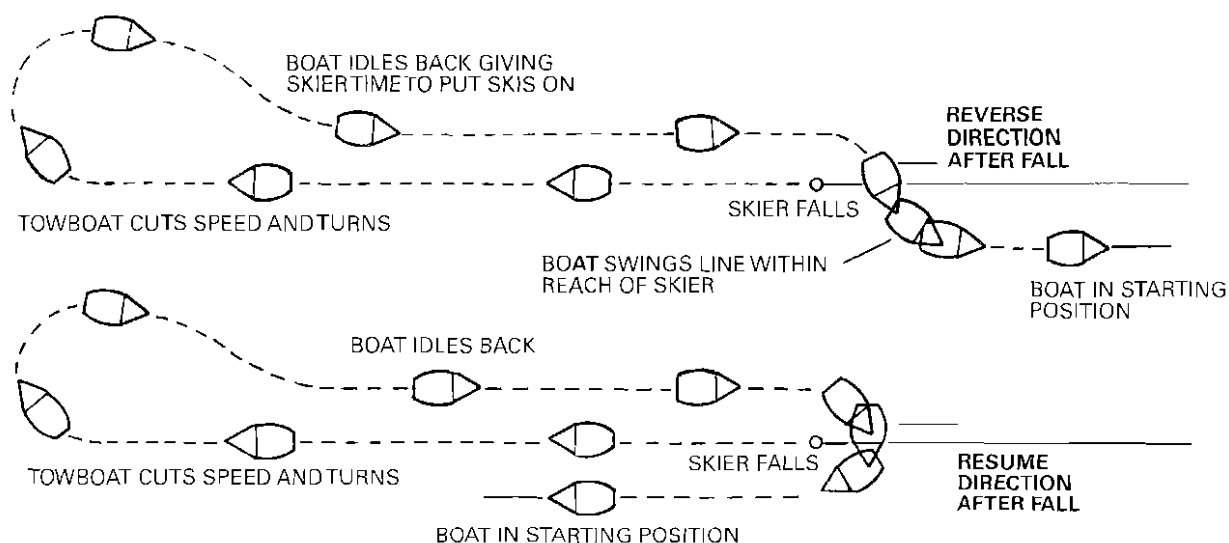

Simple towboat patterns for return to fallen skier—less rough water caused, less space used, and no broad high-speed or sweeping turns to violate right-of-way of other boats

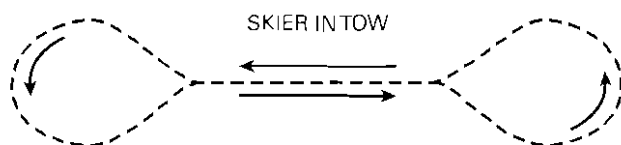

Boats should follow this "dog bone" turning path when reversing direction with a skier in tow. The boat returns on the same path between wakes.

When the skier falls, the driver, through the observer, should make certain the skier is all right. If the skier fails to wave or give the clasped hands—overhead signal, the driver should return to the downed skier as quickly as safety permits to give any help needed.

If a skier indicates he is all right, the driver should idle back to the skier, allowing time for the skier to put his skis back on. To have the best view of the skier, the driver should approach him on the side on which he is seated. Once the boat is abreast of the skier (10 to 12 feet), the driver turns sharply at idle speed to the side the skier is on, putting the motor in neutral when passing the skier. If the driver wants to pull the skier in the direction they were going when the skier fell, the driver comes around in a half circle.

In many cases an experienced driver will pick up a skier by turning sharply to the side the skier is on (once safely abreast of and past the skier) and then turning sharply in the opposite direction so that the boat is nearly on the same course as when it came up on the skier. This S course causes the stern of the boat

to swing in a broad arc, bringing the trailing line close to the skier where he can pick it up.

On small or congested lakes, a driver can reduce the boat-turning area when retrieving a fallen skier by cutting the throttle and turning the wheel sharply just as the following wake hits the stern. This stern wave pushes the boat around in a tight, space-saving turn.

Keep passengers in the towboat to a minimum. In a low-powered boat in particular, unnecessary passengers make good starts more difficult, cut down skiing speeds, and distract the driver. An observer, however, is always necessary.

As with the skier, the driver has a code to understand and live up to. Here is the Boat Driver's Safety Code:

- Always have an observer onboard to watch the water-skier while you watch forward.
- Always return quickly to protect a fallen skier, who is helpless in the water against oncoming boat traffic. The skier is your primary responsibility.
- Always drive according to the skier's ability, and avoid sharp turns.
- Always put the motor in neutral when passing a fallen skier.
- Always turn off the motor when picking up a skier.
- Always use common sense and courtesy when driving for a skier.
- Always take a water-skier into the boat using a ladder or low rear deck, avoiding any contact with the motor or rudder.

- Never ride the gunwale or the back of the seat while driving for skiing, and do not allow your passengers to ride this way.
- Never increase speed when bringing in a skier.
- Never tow skiers in congested areas, particularly swimming areas.

WATERSKIING SIGNALS

The development and the use of standard water-skiing signals has much to do with the safety record of the sport. These signals, developed by the American Water Ski Association, have been written into law in many states.

The purpose of the "skier in water" signal is to make the skier more visible to other boats that may be in the area as he waits to be picked up by his own boat. For the skier in water signal, hold one ski upright well above your head.



Skier in water

Another important signal should be used whenever a skier falls. Wave or clasp your hands high over your head to let the driver know you are all right. If the observer in the boat does not see the skier safe signal, the observer can only assume that you are hurt and order the boat to come rushing to your assistance at emergency speed, a procedure that, when uncalled for, creates unnecessary dangers.



Skier safe

Instructions to the boat in starting are given vocally. When the skier is in position, the observer tells the driver to idle the boat forward slowly to take up the slack in the line. When the line becomes taut and the skier is moving slowly forward in a take-off position, the skier yells "Hit it!" or "Go boat!" The driver then steadily accelerates the boat until the skier is up.



Faster (thumb up)



Left turn

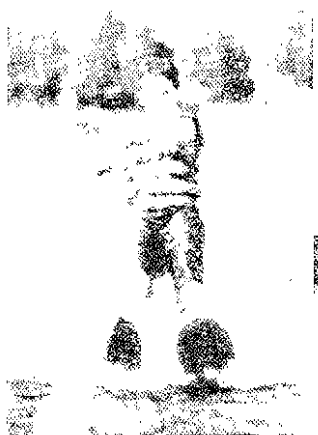

Slower (thumb down)



Right turn



Home (hand on head)



Cut motor or stop

Once a skier is under way, there is little chance of his being heard if he has to shout his instructions to the boat. Therefore, the skier directs the boat by using hand signals, as illustrated.

ACTING AS THE OBSERVER

An important function of the safety observer is to relay the skier's signals to the boat driver quickly and accurately. The essential function of the safety observer is to watch how the skier is doing, to tell the boat driver if the skier falls, and to help the driver be aware of other boat traffic and potential hazards.

The observer also is in charge of the towrope. The observer coils the rope into the boat when the skier is ready to board the boat and pays it out when necessary for deepwater starts. The observer should be ready and able to enter the water quickly to aid the skier when needed.

Everyone in the water-skiing party—boat driver, safety observer, and water-skiing buddies—needs to be familiar with BSA rules and safety codes and with the specific laws and regulations governing boating and waterskiing in the state. Each of the 50 states has its own rules. A copy of state rules and regulations can be obtained through a licensing center, a marine dealer, or the appropriate government office.

BASIC SKILLS

Learning to water-ski starts on dry land. Land practice simulates the real thing. To get ready, put on a PFD and the skis and properly adjust them.

BEACH PRACTICE

Sit back on your skis with your feet flat, knees up against your chest, and arms straight out holding onto the towline handle. Your instructor should hold the line and pull, gradually but strongly. As the line begins to pull you forward, rise slightly using your legs, keeping your feet flat in the binders, arms and back straight, and weight back against the pull of the tow grip.

Keep your back and arms straight as you rise and the skis plane up on the water. Come to almost a standing position. Your knees should be bent slightly to provide better balance and to act as "shock absorbers" on the water.

The essential point is that your arms remain straight throughout. Your legs should do the lifting, not your arms. If you find that you have a tendency to pull yourself up with your arms rather than rising up with your legs, practice the procedure until your legs know that they do the work and your arms know that they do not.

Your arms transmit the "power" from the boat to the skis. They cannot do this when bent.

A good way to determine whether you are in proper position after you are up is to drop the handle suddenly (or your instructor can suddenly ease the line). If you tend to topple backward, you are leaning back too far. To correct your position, stand up straight without the handle, bend your knees slightly, and reach out with both arms straight. When the instructor places the handle in your hands, you are in the proper skiing position. Now you are ready for the water.



Sit back on skis with feet flat, knees against chest, arms straight and outside knees.



As skis plane, rise slightly using legs, keeping arms straight and weight back.



Come to almost a standing position. Knees slightly bent, weight slightly back.

PUTTING ON THE SKIS

Putting on the skis is the most difficult part of the deep-water start. All too often a beginner finds himself floating on his stomach with his skis spread-eagle behind him. Overcome this by practicing in neck-deep water. You then can stand on the bottom and rest between tries.

The procedure for putting on skis in deep water is not greatly different from when you practiced putting on skis in shallow water. The fact that the skis (and everything else) want to float causes trouble. Push the first ski underwater as you bring your foot up to it. It may help to take a deep breath of air and duck your head underwater. This gives you better control and easier movement. Slide your foot into the front binder and pull up the rear binder around your heel. You should use both hands.

Do not hang on to the second ski as you put on the first one. Let the second ski float on the surface beside you. If you have to hold on to the towline handle while putting on your skis, slip it over your forearm and it will tend to float up near the armpit. The better way is to have the boat bring the line to you after you have the skis on and are in position.



The most difficult part of a deepwater start is putting on the skis. The best way to get accustomed to putting on skis in deep water is to first practice the technique in neck-deep water, where you can rest between tries. Show the ski underwater, take a deep breath, and duck your head underwater. This gives you better control and easier movement in putting on the ski. Let the second ski float on the surface next to you until you are ready to put it on.

THE FIRST START

Once you are able to put on your skis underwater you should have little difficulty in learning the deep-water start.

You may have some trouble maintaining your balance until you have the handle and are ready to take off. The buoyancy of the skis can upset your balance and tend to make you roll to one side or the other. You can best maintain your balance by keeping your legs bent and your skis together while treading water with your hands and arms.

In the starting position in the water, your skis no longer will be flat on the ground. They will be at an angle with the fronts pointing up out of the water. Your position relative to the skis, however, is the same as it was in the dry-land practice. Everything is merely tilted back.

The line should be trailed to you. Throwing it to you can cause dangerous loops in the line. As the boat, slowly idling, pulls the line past you, grasp the line loosely, allowing it to travel through your hands. If you are not pointed in the direction the towboat will pull you, tighten your grasp on the line to make yourself

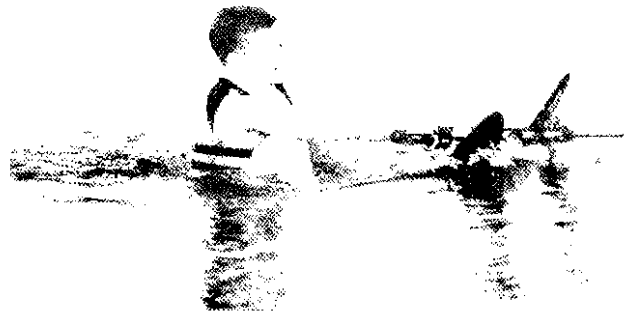

Keep ski tips pointed out of the water



Stay crouched down as skis begin to plane



Rise with arms and back straight

swing around into the proper position. Be sure the rope is not behind your head. If it is coming up behind you, lift it over your head as soon as you can reach it.

To bring up your ski tips, bend your ankles and knees, tighten your pressure on the line, and lean back against the pull of the boat. When the handle comes to you, you should have your tips out of the water and be in the starting position.

The boat should be taken out of gear momentarily as the handle comes to you to give you an opportunity to adjust your starting position. With practice you will find it easier to retain balance and keep up the ski tips with the boat in gear at idling speed. Keep your knees bent and inside your outstretched arms.

Being pulled slowly through the water, with the line between the ski tips and with no immediate effort to get up quickly, gives you the feel of the water and the skis and reduces the likelihood of spills. If you then maintain good balance and position, shout "Hit it!" or "Go boat!"

At this stage, you should be leaning slightly backward from the waist up, against the pull of the boat. Your knees should be bent so that they are between your arms. As the boat accelerates and the skis begin to plane, stay crouched down. Then you can take your time standing up, keeping the arms and back straight. A beginner should not try to stand up as if he is trying to get up on top of the water. By taking your time, you will be skiing before you realize it.

After planing up in the crouched position, rise slowly to an upright position, keeping the knees slightly bent and the arms straight. Your weight should be evenly distributed between the two skis, which should be riding 6 to 8 inches apart.

COMMON ERRORS

Most falls in deepwater starts are caused by three errors: standing up too soon, pulling the handle into the chest, and placing the skis too close together. Standing up too soon will result in your being pulled forward over the skis. Pulling the handle into the chest in an effort to stand up will result in your falling over backward. Placing the skis too close together will result in your falling or rolling to one side.

In the early stages of the start the skis are not planing, and the resulting resistance can be more easily handled by staying down. As the skis begin to plane and the resistance is less, you can easily assume a balanced skiing position. Take your time and make certain the skis are planing before you stand up.

You must raise your body weight through leg power. If you pull in on the handle in an attempt to stand up, the skis will slide forward and you will probably fall backward. If you find it difficult to stand up with leg power, you may be leaning back too far.

Some skiers roll to one side or the other on takeoff. To remedy this, keep the skis apart to ensure the best stability. Make sure your bent knees are against your chest, and do not attempt to stand up until the skis are planing.

Another common error is leaning forward when you are on top of the water. A person in this position usually is not aware of it—having straightened his legs, he thinks he has straightened his entire body although he is still bent at the waist with his head and shoulders hanging over the tips of the skis. In this unbalanced position, a skier is bound to be pulled forward into the water. The remedy is simple—straighten your body, keeping your knees slightly bent as you rise up.



Proper skiing position

Another frequent error is pulling in your arms to maintain balance or to take up imagined slack in the line. Beginners often think the line is slack when it is not. The trouble with pulling in your arms is that in doing so you are in fact pulling your body up to the handle. Then, when you straighten your arms again you actually do slacken the line. When the speeding boat snaps the line taut, you are thrown completely off balance.

If you need to compensate for a momentary loss of balance, give a short jerk on the handle rather than a long pull. This will usually do the job. You also minimize loss of balance by keeping your knees slightly bent (and distributing your weight evenly between the two skis). Particularly, remember this in crossing the wake in rough water and in making turns. Keeping your knees straight locks out the spring that helps you absorb any jolts and maintain your balance.

Do not worry if you do not make it the first time. The average beginner requires five or six tries. Many young people, however, are able to ski the first time. When a beginner requires an unusual number of tries, the reason is usually a fear of falling. Remember that falling—naturally more frequent when you are beginning—is just part of the fun.

FALLS AND STOPS

Falls usually are not dangerous. If you are about to fall, first make certain that you really are falling. Amazing recoveries often are made by simply hanging on to the tow handle. If you really are falling, let go of the towline, lower your chin, and tuck your limbs into your body. Avoid falling forward. Fall to the back or to the side. In a forward fall you are more likely to fall into your skis and possibly cut yourself. After the fall, clasp or wave your hands high over your head to let the boat know you are all right.

You sometimes have to fall or stop short on purpose. Hitting a fixed object such as a piling, pier, or sandbar, or running into another boat or a floating log is an unpleasant prospect while skimming over the water at 20 or 30 miles an hour. If you are going too fast or are too close to steer away, release the towline and crouch slightly as you let it go. If you are still going too fast, you can slow yourself rapidly by sitting on the back of your skis and dragging your hands in the water. Also be prepared to topple to one side deliberately if necessary.

Landing when you are through skiing is easy. All you have to do is let go of the towline. Crouching slightly as you let go, you will slowly sink into the water as your

speed decreases. Spread your arms out for extra balance. After landing in deep water, wait for the boat to pick you up. Remember to give the "skier safe" signal as soon as you are down, and to use the "skier in water" signal if there is any other boat traffic.

Never ski directly toward shore in landing or at any other time. If you misjudge and suddenly hit bottom, you will be thrown into a bruising fall. Ski parallel to the land. Never attempt to land close to a dock or a float or any other solid object. If you want to slow yourself down while landing, squat and drag your hands in the water as in an emergency stop.

CROSSING THE WAKE

Until you become accustomed to your skis and the sensation of skimming along the surface, play it safe and stay between the wakes of the boat. The water is smooth there. Drifting to the edge of the wake with the skis parallel to the wake can easily cause you to catch a ski edge and topple over.

When regular water skis are planing on top of the water, they head in the direction the tips are pointing. You can change course by "banking" the skis. For example, if you want to go to the left side of the wake, shift a little more weight to the left ski. This slight shift in weight causes more resistance to the water on the left side of the skis, turning them to the left.

Balancing will become increasingly easy as you get the feel of the skis. The delicate balance at slow speeds is similar to the situation with a bicycle. Beginners tend to wobble until they are confident of their ability to maintain control. As experience gives you greater control over your feet, you will bank the skis opposite to any wobble, almost automatically counteracting any takeoff difficulties. Many beginners think their problem is faulty skis, but the skis somehow "get better" as the skier gains experience in controlling his own feet. As in other sports, this almost automatic reflex control results from practice.



For a quick stop, sit back on the skis and drag your hands in the water.

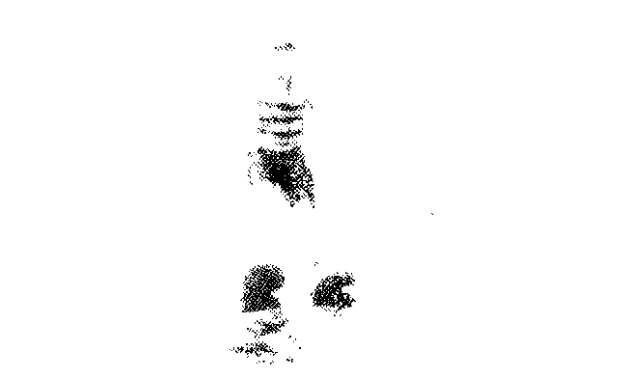

For an easy water landing, release the tow rope and keep your balance as you slow down and sink.



Stay between the wakes.

Once you master control of your skis, you are in for one of the biggest thrills in waterskiing—crossing the wake to the calm water outside. Rough waves will not capsize a boat if the boat heads into them instead of taking them broadside. The same general idea applies to crossing a wake on water skis.



Crossing the wake

Before venturing across wakes, practice turning back and forth between the wakes. The more you turn and the harder you pull, the faster you will travel from side to side.

Once you have the feel of turning the skis, you are ready to go outside the wakes. Approach and cross the wake at an angle with knees bent to take up the lift of the wake. Keep your momentum going as you cut across the wake. Once outside, turn your skis toward the boat wake, again at an angle.

As you go back and forth and become accustomed to the lift of the wake, you will be able to turn sharper and pull harder, increasing your speed across the wake each time you try it.

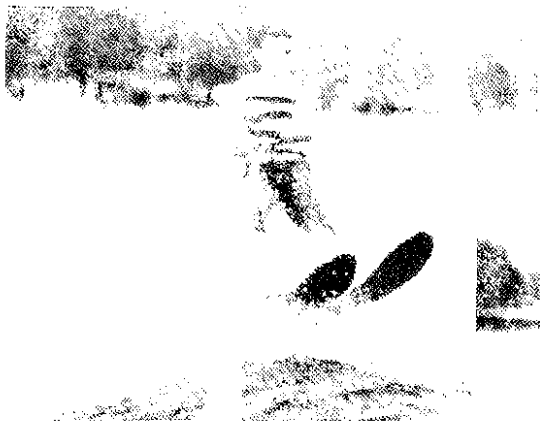

To spring into the air, push down with your legs just as you hit the lip of the wake



Hold your position while airborne

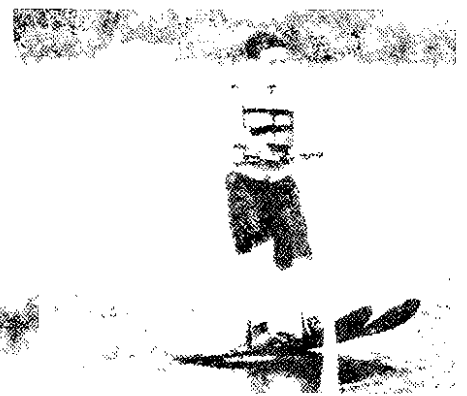

Land with the back end of the skis hitting first, bend the knees slightly to help cushion the landing

JUMPING THE WAKE

Jumping the wake is an advanced maneuver that should be attempted only after you have become an experienced, self-confident water-skier on both one and two skis. This is not part of your merit badge requirements, but it would be a first step toward trick-skiing or wake-boarding. When jumping the wake, you use the boat wake as a low ski jump. Just crossing the wake, you will have noticed a lifting effect as you ride up the edge. Jumping off merely requires giving yourself a little extra spring as you hit that point.

Normally, you allow your knees to flex as you cross the wake, thus taking up the shock. To jump the wake, start by keeping your slightly bent knees locked, causing you to lift slightly off the wake. Do this several times to get the feel of the wake lift.

Next, straighten your legs, pushing your body weight up just as you hit the lip of the wake. You will find that as you turn sharper and pull harder you will need to initiate this springlike action a split second before you get to the lip.

In the air, be sure to keep your ski tips up by controlling the skis with your ankles.

With practice you can cut from far outside, hitting the wake and jumping across to the other wake. If your boat has a very shallow wake that makes this impossible, shorten the towline to 50 feet. The higher wake closer to the boat will give you a better lift.

In landing when jumping the wake, the back end of the skis hit the water first. If the tips hit the water first, they will dig in and topple you over. Let your knees give slightly to cushion the landing.

THE SKIER'S SALUTE

The "skier's salute," performed at virtually every water-ski show, is done by gracefully lifting one ski from the water with the front of the ski angled upward. Learning the salute is a step toward learning to ride on a single ski.



Practice the salute a few times on land before taking to the water. Shift about 80 percent of your weight to one ski. Then lift the other ski, bringing the knee up and in toward the chest as you lean back slightly. Bend your ankle to keep the ski tip up. The tip must leave the water first and return to the water last. If it were to hit first on the water, it would dig in and send you flying headfirst over it.

Keep your arms straight, and keep your skiing leg only slightly bent. Practice with one foot and then the other on dry land. Then do the same on the water.

The water between the wakes directly behind the boat is the most consistently smooth and thus the best for learning the skier's salute. Ski in the normal stance, arms straight and knees slightly bent and flexible. The only difference from your normal stance is that you lean back your upper body more than you would while skimming along on two skis. Too much weight toward the front of one ski will cause it to dig in and wobble. When you shift your weight toward the back, the ski will plow through the water straighter and with greater stability.

If you have difficulty lifting the ski, you probably have not transferred enough weight to the other foot. You cannot lift a foot you are standing on.

ON ONE SKI

Learning to ski on a single ski does not require any special equipment. Use your regular pair of skis, a regular 75-foot towline, and your regular PFD. Later you can use a ski with a rear binder if you want.

The boat speed for switching from two skis to one should range from 18 to 22 miles per hour, with higher speeds for heavier skiers. The correct speed is the one that allows the skier to ski without undue strain from a bogging ski.

Having learned the skier's salute, the switch to skiing on one ski is largely a matter of dropping the second ski. Which ski you drop depends on which foot you feel more comfortable skiing on. It is not a matter of being left-footed or right-footed; you will find that you will need as much strength in your rear leg as you do in the forward leg. This is the reason for learning the skier's salute on both legs. You will drop the ski off the foot you can lift the easiest and keep the ski on the foot you ride the best.

DROPPING THE SKI



Shift your weight to one ski

Make your first attempts to ride on one ski in the smooth water directly behind the boat and between the wakes. Shift your weight to the ski you intend to use. Then gently lift your heel out of the binder of the ski you are going to drop off. Let that foot and the ski drift toward the back. Keep your heel up, and the force of the water on the ski will pull the front binder from your foot. Do not attempt to kick the ski off or you will lose your balance.



Lift your heel out of the binder, and let the water pull off the ski.

Keep your free leg extended to the rear with knee bent so that your foot is free of the water. Bend your skiing leg slightly and lean farther back to compensate for the additional drag of your weight on one ski. You should be conscious of your weight being borne more by the heel of your one skiing foot than in regular skiing.



Keep your free leg extended to the rear, and lean farther back.

If you are properly balanced, you should have little difficulty skiing in this position. Place your free foot on the back of the ski by carefully placing the toes down on the ski immediately behind the heel binder of your skiing foot. Do not look down at the ski. Once you have touched your toes down gradually, place the entire foot down and shift body weight to that foot until you have your weight equally distributed on both feet. Experiment by shifting weight slightly back and forth until you find the skiing position that feels more comfortable and provides you with the best control over the ski.



Place the free foot behind the heel binder on the ski, and shift weight to the rear foot.

Before learning to place the free foot on the rear of the ski, a skier often will start to zigzag uncontrollably, eventually falling. This results from too much weight forward, causing the ski to "seek" or "hunt." The extended skiing leg does not help matters as it swings back and forth.

A simple trick can help you avoid zigzagging. Bend your skiing leg more and firmly place the toes and instep of your free leg in the water slightly to the rear and a foot or more away from your ski. Exerting pressure on this foot will establish directional stability. Once again on a straight course, you can attempt to place the free foot on the rear of the ski.

The rest is easy. Simply keep your weight back, knees slightly bent, and arms straight. To turn, just lean in the direction you want to go. The harder the lean, the faster the turn.

Do not try to cross the wake immediately. First master the steering technique. Practice shallow, slow turns within the wake until you are sure of your control.

When you are ready, cutting across the wake on a single ski is one of the top excitements of waterskiing. You use essentially the same technique used to cross the wake on two skis. Cross quickly and smoothly at a positive angle. As you hit the crest, bend your knees slightly to help cushion the shock.

*The harder the lean,
the faster the turn*



*As you cross the wake, bend
the knees slightly to help
cushion the shock*



ONE-SKI START

If you can start on one ski, you won't have to chase after a loose ski every time you switch from two to one. Learn the single-ski start on one ski of a standard pair, or make use of a slalom ski if one is available.

Sit on the heel of your ski with your knee bent well into your chest. Your free leg should be stretched out behind you, down into the water as far as possible. The line should be inside your ski—to the left if you ski right-footed, and to the right if you ski left-footed. Your free leg acts as a rudder for steering and partly substitutes for stability that ordinarily comes from a second ski. Do not be in a hurry to pull up that free foot. Drag it deep in the water as long as possible. Wait for the boat to pull you out of the water.

With but one ski to support your weight, waiting for sufficient speed is essential. As you come out of the water, lean backward slightly until you are in the normal single-ski position.

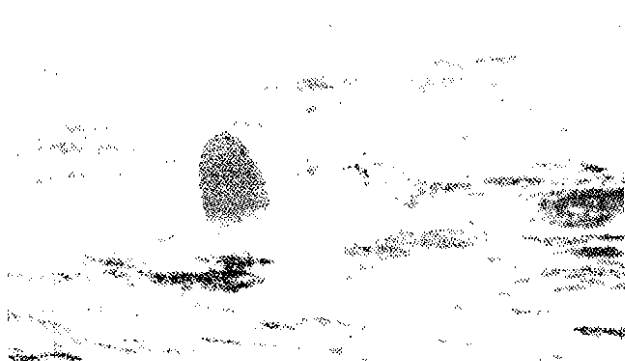

Keep the towline inside the ski

A tendency to fall toward the side of the free leg can be compensated for by twisting your body slightly to that side. The line will then be pulling you away from this "falling" side. If necessary, also ease up slightly in dragging your free leg.

The biggest job is keeping your ski headed in the proper direction. Keep your eye on the ski tip throughout your start; make sure the ski line is on the inside of your ski—to the left if you are right-footed, and to the right if you are left-footed. Use your free leg as a rudder to keep the ski lined up with the path of the boat.

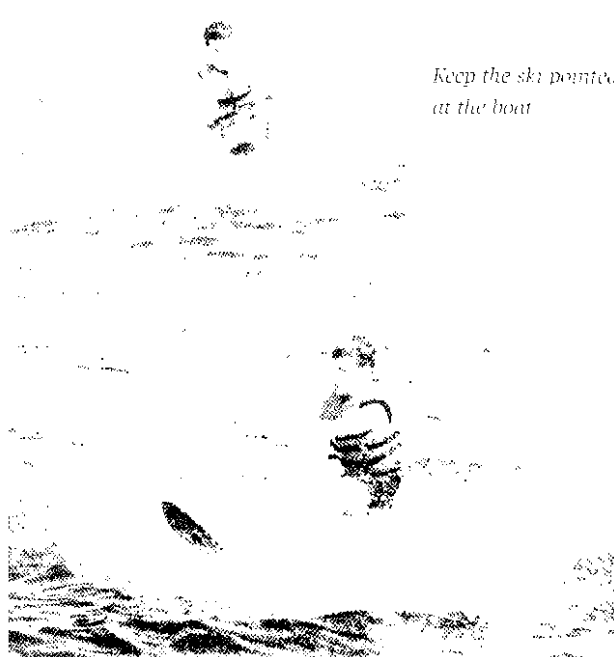

*Keep the ski pointed
at the boat*

Drag the free foot so that it acts like a rudder.

COMPETITIVE WATERSKIING

Competitive waterskiing is an exciting sport. The Varsity team interested in waterskiing should contact local sources for information about upcoming events. If the team is located in a remote area or in an area where competitive waterskiing is unavailable, individual competition can be conducted on a team level. Perhaps several teams within the district or council could stage an event. Scoring by individual as well as by team could be developed.

Before undertaking the activity, the Varsity team choosing to learn competitive skiing must have the resources available. These resources include not only the necessary equipment but also individuals competent in the sport to serve as coaches.

Most competitive waterskiing tournaments consist of three events: slalom waterskiing, trick waterskiing, and jumping. **Ramp-jumping events are not included in**

Varsity team waterskiing competition. Those interested in learning the skills of ramp jumping should do so as individuals, not as members of a Varsity team.

SLALOM WATERSKIING

In slalom waterskiing competition, the skills of skiing on one ski are put to the test. The slalom course consists of six buoys placed 41 yards apart in a straight line. Slalom waterskiing is similar to recreational skiing, with the added challenge of the six buoys.

The boat and skier approach the course at a constant speed of 20 to 24 miles per hour. The skier zigzags through the six buoys: three to the left and three to the right. After the skier successfully passes through all six, the length of the towline is shortened. The skier again passes through the six buoys and the towline is again shortened. This shortening of the line and additional runs through the buoys continue until the skier falls.

The slalom course is best learned by attempting the run at a slower speed and with only three buoys in place. This is called a half course or minicourse. The boat should travel at 20 to 24 miles per hour. As the boat passes the first gate, the skier leans to the right and skis to about 20 feet outside of the wake. As the skier approaches the first buoy on the right side, he will be about 5 feet wide of the buoy and should begin his turn to the left at least 10 feet prior to arriving at the buoy. The buoy marks the point where the skier finishes his turn, not where he begins it.

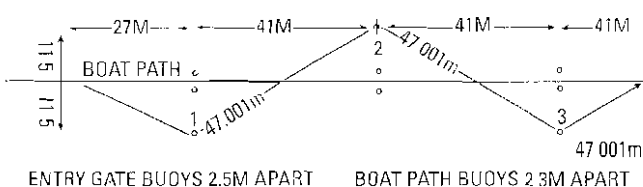

The slalom minicourse

As soon as the skier passes the buoy, he begins to concentrate on his pulling position. His body remains leaning to the left, with the handle down low and both knees flexed. He continues this lean through both wakes of the boat. As he passes through the second wake, he lets up on the pull. The ski will glide and begin to slow down. At this point, the skier should be approaching the boat gate on the left side of the wake. As soon as the skier feels the ski slowing, he leans to his right (beginning his right turn) as he passes between the two boat gate buoys. He then repeats the pulling position to the right.

The most common difficulty experienced by skiers will be a slackness in the towline. This slackness is caused by pulling too long or by not having the knees bent sufficiently.

After the skier can pass through the half course without difficulty, he should practice going around the boat gates rather than through them. He should also continue on the mini course until he can manage it with boat speeds of 24 miles an hour using a towline of 60 feet.

Next comes the full course. Begin at a boat speed of 20 miles an hour and slowly increase the speed as proficiency increases. Then begin shortening the towline as if in a tournament.

Running the slalom course can be fun for all members of the team. Running a mini course can be just as exciting. Above all else, remember to have a qualified person recruited as the team consultant.

TRICK WATERSKIING

Varsity team members enjoy tricks. Playing tricks on their friends or having tricks played on them always brings laughter and excitement. The challenge is to keep these tricks positive rather than doing harm or embarrassing those involved.

Tricks on skis can also be a lot of fun. The gyrations and gymnastics performed on skis are limited only by the imagination and physical abilities of those doing them.



Trick waterskiing requires skills not used in recreational skiing. Trick skiers must develop gymnastic skill and then use this ability on a water ski. Trick skis have bindings and are shorter and somewhat wider. The length of the ski to use is determined by the skier's body weight.

On the trick ski course, the motorboat travels in a straight line at a slower speed than in the slalom. Two passes are made, each lasting 20 seconds. The skier selects the towline length as well as the speed of the boat.

The skier is given points for the number and difficulty of the tricks that are performed in each of the two passes. Points are scored as the skier completes as many twists, flips, and turns as possible during the run. The more difficult the trick, the more points are scored.

In competitive waterskiing, trick skiing is the easiest to learn in that a slalom course is not needed. Also, trick skis are less expensive and a boat with a smaller motor (with less horsepower) can be used.

There are three keys to making sure trick skiing is both fun and safe:

- Have the proper equipment. This includes properly fitted skis and a helmet.
- Know the movements of the trick before attempting it. Many of the tricks done in the water are best learned and mastered on dry land.
- Have understanding and communication among the skier, the observer in the boat, and a competent person driving the boat.

Learning to trick ski begins with the same basics covered earlier. The skis are much shorter and wider, and they do not have a stabilizer fin on the bottom.



After successfully getting up, get the feel of the skis and work on your body position. The skier stands as straight as possible, knees are bent forward, and ankles are bent slightly. The arms also should be bent slightly to help take up any shock from the boat's pull.

Begin crossing back and forth between the wake without forcing the skis one way or the other. Next, try crossing the wake. Keep your knees bent forward and the handle down low. Repeat these wake crossings until you are confident with this new feeling on skis. After you're able to cross the wake without difficulty, it's time to learn a few basic trick maneuvers.

SLIDE TO THE SIDE

Remain behind the boat in the center of the wake. Pull the towline handle slowly, in and down, without moving the shoulders. If you slide forward with acceleration, the movement was executed properly. If no movement was felt, the shoulders were probably moved down as the handle was pulled inward. Continue this exercise until proper movement is felt.



Slide to the side

Next, pull the line down and in. When movement is felt, bend the knees a little more and turn the skis to the right or left. As the skis begin to turn, release the back hand. Permit the skis to slide for a short distance and then return to the front.

Convincing a skier not to be afraid of all right is the greatest challenge in teaching slides to the side. Continue practicing until you are sliding rather than traveling across the water.

The slide is a basic building block for all tricks. After mastering the slide to both sides, proceed to the next trick.

TURNING

Performing a 180-degree turn means moving 90 degrees farther than in the side slide. This trick puts the skier in a position of seeing where he has been.

FRONT-TO-BACK

Pull on the handle slightly more than in the slide. Release the back arm, and continue the turn of the skis using your knees. Pull the handle into the back with the other hand. You should now have your back to the boat, looking up, knees slightly bent, and hands holding the handle while touching the small of the back.



Front to back



Most falls occurring during this trick are caused by the skier straightening his legs during or at the conclusion of the turn, which would result in a fall away from the boat. Falls toward the boat are caused by weak pulls on the towline or letting the handle out when reaching the reverse position.

BACK-TO-FRONT

It is always easier to return to a familiar position than to try a new one. The back-to-front is probably the easiest trick to learn because of this feeling. Simply let go of the handle with one hand while keeping the handle in the small of the back with the other hand. As the boat begins to pull you around to the front position, keep the handle in close to the body with your knees bent.



Back-to-front



Before proceeding to the next trick, the skier should be able to go backward 180 degrees to the left, return forward, and then go 180 degrees to the right and return forward.

360 DEGREES

The 360-degree turn begins by executing a 180-degree turn from front to back. As you reach the back, grab the handle with the free hand while letting go with the turning hand. This causes you to continue your path around to the front. Continue practicing this trick until you are comfortable making a 360-degree turn to the left and then to the right.



Backward sking

BACKWARD SKIING

Next, try skiing backward for a longer period of time. Execute the 180-degree turn and remain in the backward position. While skiing backward, travel left and right inside the wake.

USING ONE SKI

After mastering these tricks and skiing backward, the skier is challenged to move to one ski. Start by getting up and remaining in the wake of the boat. Slowly shift your weight to one ski, ease back, and then shift it to the other ski. Determine which ski is more comfortable. Again, shift your weight and lift the drop ski slowly until it clears the water. Next, drop the ski and assume the slalom position. Do this until you feel comfortable and confident while skiing on one ski.

ONE-SKI TRICKS

After becoming confident in slalom waterskiing on trick skis, it's time to learn one-ski tricks. After getting in the wake of the boat, execute a 180-degree turn. While skiing backward, lean onto the ski chosen for slalom. Next, shift the weight from the drop ski. Get the feel for the slalom, then release the drop ski.

At first, the skier should drag his free foot in the water for balance and stability. Then he should slowly move his free foot to the ski and place it behind the ski foot. If the skier loses his balance, he should put the back foot into the water to regain stability. Master slalom waterskiing before proceeding.

When you feel comfortable slaloming on one ski, you can begin learning the tricks already mastered while on two skis. The procedure for the single ski is the same as for two skis. Remember that while on one ski the ski surface is reduced by half and the need to pull is twice as important. Above all else, the need for knee flexibility is more important for control and balance. Learning more advanced tricks should be left to the instructor.

WARM-UP AND CONDITIONING EXERCISES

Healthy young players are always ready to play the game and rarely look forward to any preliminary "exercises." It is important to avoid making the warm-up drudgery. Interpret its importance in helping get players ready for strenuous exercise.

The warm-up exercises used and the attitude about them will strongly influence the Scouts' lifetime attitudes about exercise.

Select new exercises for each practice, and also repeat some that have been done before.

To begin, players position themselves in a circle, in double lines, or in a semicircle facing the leader. Let players take turns choosing and leading exercise with the players.

Remember: Demonstrate the exercise or game first. Tell why the exercise is important. Have players do the exercise slowly together. Then exercise at regular speed.

STRETCHING EXERCISES

- **Deep breathing.** Ask players to take several deep breaths, expanding the chest fully by inhaling, then relaxing while exhaling.
- **Slow arm circles.** Walk in a circle. Swing arms forward and then backward.
- **Side benders.** Hands on hips, bend to one side, then the other.
- **Trunk twisters.** Hands on hips, twist to one side, then the other.
- **Toe touching.** Touch opposite toe, with knees slightly bent.
- **Front thigh stretch.** Bend knee. Grasp shin bone and pull knee close to chest.
- **Back thigh stretch.** Bend knee and bring heel up toward back side. Grasp ankle and pull toward back side.
- **Neck rotation.** Gently rotate head from side to side.
- **Ankle rotation.** Rotate the foot without moving the knee, then with knee rotating.
- **Thigh and leg stretch.** Take position of sprinter on toes. Lower the hips to the ground without moving feet. Repeat each side.
- **Forward crawl stroke.** Stretch arms forward in crawling motion.

STRENGTH

- **Pull-ups.** Using an overhand grip on a horizontal bar, raise the body until the chin is above the bar. Lower the body slowly.
- **Sit-ups.** Lie on the floor. Pull the feet back, raising the knees. Place hands on the shoulders or behind the neck. Raise the body until the nose touches the knees.
- **Push-ups (modified).** Assume a hands-and-knees position on the floor. Bend the arms and lower trunk until the chin touches the floor.
- **Isometrics.** Ball squeeze—Squeeze a tennis ball in each hand. Hold for 8 to 10 seconds. Repeat.

AGILITY

- **Shuttle run.** Do wind sprints for 60 feet, then turn around and return to start.
- **Footwork.** Standing with feet shoulder width apart, run in place. Move left, right, forward, or backward on command of the exercise leader.
- **Jumping.** Place a 3-foot rod (dowel) between two cement blocks. Jump over rod—back and forth, then left to right to left.
- **Jump rope.** Skip on both feet, on left foot, on right foot, alternate skip from left to right to both feet.

WATERSKIING PRACTICE

Practice sessions are held during the Varsity team participation in the waterskiing activity. Practice sessions can occur as part of the team meeting or be held at a separate meeting. These sessions develop the Scout physically and mentally.

Many opportunities will occur to blend the sport of waterskiing with the game of life. Smart coaches and captains use these opportunities to strengthen the individual Scout as well as the Varsity team.

Practice sessions have four parts:

- 1. Warm-up and conditioning exercises.** Simple warm-up exercises, both on land and in the water, allow for loosening of the muscles and help in avoiding injuries. Vary the pace and type of exercise. Questions should be asked to stimulate thinking about proper eating habits and the importance of exercise throughout life. This portion of the meeting should take about 10 minutes.
- 2. Skills development drills.** Teaching fundamentals of waterskiing may be necessary as a part of this meeting. It is essential that all team members understand these basics. Take time to teach basic skills at every practice session and plan simple drills to reinforce the points.
Players should work both as individuals and in groups of two to four so that no one feels bored or slighted. This instruction should be brief to keep things moving and to save time for skill training in the water.
- 3. Team talk.** Make this a regular, normal part of practice. Use it for education and personal development. Team members should be encouraged to talk about such things as rules of the sport, principles of team play, responsibilities in the boat, team tactics, and concepts of fair play.

These rules, principles, positions, tactics, and concepts apply to everyday life as well as to the sport of waterskiing. These discussions should be a regular segment of practice as well as take place at any appropriate time.

- 4. Practice Sessions.** Several groups should be going on at the same time. Team members in ability groups work to increase their individual skills.

These practice sessions should also include some general sessions on course layouts, driving the boat, rules of safety that are to be used, etc.

CALL A TEAM PARENTS' MEETING

After you have had a couple of practice sessions, ask players and their parents to attend a brief meeting. You might want to have the meeting after a practice session or at a special time when most players and parents can attend.

Some ideas for the meeting follow:

- Introduce team leaders (coaches).
- Discuss practice and tournament requirements and schedules.
- Distribute a schedule that the team will be following.
- Discuss the major points of Varsity sports philosophy and clarify how this philosophy is being implemented.
- Explain the basics of waterskiing and suggest some things that help make watching the sport more enjoyable.
- Talk about conduct during the competition, both in and out of the water. Ask parents to help you with this during the competition.
- Announce any special family events that are scheduled.

CARE AND PREVENTION OF INJURIES

Safety awareness is as important in Varsity waterskiing as learning the skills of the sport. All instruction and coaching should include appropriate safety measures, and it is always the responsibility of the coach to supervise the preparation of Varsity team members for competition so that the likelihood of injury is minimized.

Waterskiing is only as safe as the environment established by adult leadership for the sport. Coaches should take all necessary precautions to help prevent accidents, but they must also be prepared to respond if an accident does occur.

Coaches are responsible for both prevention and immediate care of injuries, but the emphasis for everyone must be on prevention of injury and safe, accident-free play.

COACHING SUGGESTIONS TO HELP PREVENT INJURY

Coaching styles have much to do with establishing a safe environment for skiers. Be creative and flexible, but be prepared and well-organized for practice sessions and games. Design drills to meet the special needs of each player and the team.

Follow the practice outline suggested earlier in this manual. Be sure to include all four segments of the practice session, including warm-ups, drills, team talk, and practice.

Try to actively involve all of your players throughout practice with a minimum of sitting, standing, and waiting around. Provide as many opportunities as possible for each player to practice on the skills that he needs most. Plan instruction and competition by taking into account individual differences in skill and experience. Try to teach skills in their proper progression.

Even when coaches emphasize prevention of injuries through proper warm-up, conditioning, supervision, and education, from time to time injuries do occur and first aid must be provided. Be prepared to respond immediately with appropriate first-aid procedures. Never move an injured water-skier unless water conditions require it. Never attempt treatment that goes beyond your own training and experience. Your duty is not to provide treatment, but rather to provide immediate first aid to the injured skier.

There are normally fewer major injuries in waterskiing than found in contact sports. However, recognition of serious injury is the primary responsibility of the coach, and it must be followed by appropriate treatment by trained medical personnel.

FIRST AID

Waterskiing, like most other sports, has its own set of precautions. The conditions described here represent those that should concern any safety-conscious water-skier.

Hypothermia occurs when the body's core temperature falls below the normal range. Any combination of cool weather, wet skin or clothes, wind, exhaustion, or hunger can lead to hypothermia. Waterskiing presents several risk factors for this condition. As the body cools, the victim will shiver in an attempt to create heat. Be aware of these danger signs: loss of muscle strength and coordination, as well as disorientation or incoherence, and pale or bluish skin tone. In severe stages, shivering stops, unconsciousness follows, and death is possible unless immediate treatment is received.

Anyone who starts to shiver, or who shows discoloration around the lips or cheeks, should immediately be taken off the water, thoroughly dried and put in dry clothing, and moved to a warm place. If no warm shelter or other heat source is available, the victim should be pressed closely with one or more persons so that heat can be transferred through direct skin contact.

Heat exhaustion and **heatstroke** result from overheating when the body can't keep itself cool enough. If a water-skier feels dizzy, faint, nauseous, or weak; develops a headache or muscle cramps; or looks pale and is sweating heavily, treat for heat exhaustion. Have the person lie

Injury	Suggested First Aid
Muscle pulls, sprains, and bruises	Use ice pack immediately to reduce swelling. Speed of application is essential.
Small cuts	Apply pressure to reduce bleeding. Wash with antiseptic solution and apply sterile dressing if necessary.
Nosebleed	Have skier pinch nostrils and hold until bleeding stops. Apply ice pack.
Foreign body in eye	Pull upper lid down, holding eyelashes. Wash out with eye-cleaning solution.
Fainting	Rest in cool place. Try to relax skier and slow down breathing.
Scrapes and bruises	Wash with cleansing solution. If necessary, cover with gauze.
Elbow or knee injury	Elevate area and apply ice pack. Refer to physician if pain persists.
Back or neck injury	Keep the skier calm. Do not allow the skier to move or sit up if pain is severe. If pain is slight, apply ice pack.

First aid is the immediate handling of athletic injuries. Refer a hurt skier to the family physician for followup treatment if pain persists.

down in a cool, shady spot with feet raised. Loosen clothing and cool the person with a damp cloth or a fan. Have the victim sip water. If the condition worsens, get medical help. Recovery should be rapid. Heatstroke is the extreme stage where **dehydration** (body water loss) has caused a very high body temperature and a cessation of sweating. The pulse is extremely rapid and the person will be disoriented or unconscious. The victim must be cooled immediately through immersion or with cold packs, and the fluid level of the body must be increased. Treat for shock and seek emergency medical help.

Sunburn is a familiar condition commonly associated with boating and waterskiing. Remember that reflected sunlight from the water or boat surfaces can be as bad as direct exposure. Cover up, use a waterproof sunscreen, and limit your exposure time. If you begin to redden or feel discomfort, get out of the sun.

Contusion is the medical term for bruises—those black-and-blue marks that may appear on the arms and legs. Most bruises are not serious and are easy to recognize and treat. The discoloration is caused by blood leaking into damaged skin tissue, usually by a blow from a blunt object. Covering the site of a new bruise with a cold compress or towel for 30 minutes will help reduce discoloration, pain, and swelling. Also, slow the flow of blood into the damaged tissues by resting the injured area. To help fade the discoloration and reduce swelling, apply a warm, damp cloth 12 to 24 hours after the injury. Bruises that include possible bone injury, or any contusions on the head or abdomen coupled with sharp or persistent pain, should be seen by a medical professional.

Lacerations, incisions, and abrasions (cuts and scrapes) may occur during skier falls, or more likely when climbing in and out of the boat or loading gear on a rough dock. As in other situations, the wound should be cleaned, disinfected, and covered. The boat first-aid kit should provide for minor wound treatment. For severe bleeding injuries, control bleeding with direct pressure or at pressure points until emergency medical help is available.

In waterskiing, **blisters** are most likely to occur on the hands from the towrope handle, and on the feet and ankles where the ski binders rub. Water-skiers should be attentive to any tenderness or sensitive areas (“hot spots”) that indicate the start of a blister. You may be able to adjust your grip, or loosen or reposition ski binders to avoid the sensitive area. If not, be smart: Listen to your body and quit for the day. If you have no choice but to continue the activity, gloves and wet socks or booties might work. Moleskin generally is not effective in wet conditions. Treat blisters as in any other situation.

Hyperventilation is the result of “overbreathing” (either deliberately or as a result of panic), which depletes the level of carbon dioxide in the body and suppresses the breathing reflex. The likely result is dizziness and fainting. Such a condition is unlikely in waterskiing if new skiers are properly taught and prepared for each new skill level. If a skier should at any time show signs of panic, however, the skier should be brought into the boat or onto shore and calmed. Before resuming any activity, determine and resolve the cause of the panic.

Cardiopulmonary resuscitation (CPR) is the important first response in the event of a cardiac emergency, and such emergencies can occur as the result of any strenuous activity. CPR is used in drowning accidents where submersion has caused respiratory and cardiac arrest, and persons trained in CPR should be included in every waterskiing outing. The *Boy Scout Handbook* and the *First Aid* merit badge pamphlet explain these skills and when they should be used.

WHITEWATER CONTENTS

Background	145
Program Fields of Emphasis.	145
River Safety	145
International Scale of River Difficulty.	146
Equipment	146
Paddling technique.	150
Maneuvers	151
Fundamentals of River Reading	160
Rescue	164
Resources	167

WHITewater

BACKGROUND



Throughout the years, many youth (and adults) have dreamed of the adventures of Huckleberry Finn on the Mississippi. Today, it might be shooting the rapids in a Class III river as you dodge rocks and low-level dams or drifting lazily downstream without a care in the world—except maybe catching a fish or two for

supper. Sound like fun? You bet, when done properly!

This chapter introduces the Varsity Scout team to the exciting sport of whitewater. The chapter contains an introduction to the sport followed by sections on river safety, equipment, paddling techniques, maneuvers, fundamentals of river reading, and rescues.

There are many streams, creeks, and rivers throughout the United States waiting for your Varsity Scout team to answer the challenge. A lot of fun is in store for you—and who knows, maybe ol' Huck will drop in for supper.

PROGRAM FIELDS OF EMPHASIS

The following ideas will help you plan a well-rounded program. Program managers carry out these ideas with help from a team committee member.

ADVANCEMENT

- Review each Varsity Scout's advancement status.
- Conduct a Whitewater merit badge clinic.
- Monitor the team advancement chart regularly.

HIGH ADVENTURE/SPORTS

- Program manager outlines or updates the team's annual special high-adventure event (Philmont, Florida Sea Base, etc.).
- Plan a whitewater activity.

PERSONAL DEVELOPMENT

- Visit a local environmental agency to learn about the care of waterways.
- Design a fitness program for team members that strengthens the muscles used in whitewater experiences.
- Have a CPR course for team members.

SERVICE

- Conduct a cleanup on a local waterway.
- Assist your local game and fish commission in tagging fish.

SPECIAL PROGRAMS AND EVENTS

- Participate in an aquatics program offered in your community.
- Organize and conduct a short moving-water trip.
- Visit another team carrying out an aquatics program. Participate with them in their outing.

RIVER SAFETY

AMERICAN WHITewater AFFILIATION SAFETY CODE

The rushing current offers numerous possibilities for mishaps.

Safety must be a factor in every decision you make. An excellent guide to follow is the American White-

water Affiliation Safety Code:



1. Be a competent swimmer.
2. Wear a personal flotation device (PFD).
3. Keep your canoe under control, always!
4. Be aware of river hazards and avoid them.
5. Boating alone is not recommended; preferred minimum is three craft.
6. Be suitably equipped.
 - a. Wear shoes (tennis shoes or special canoeing shoes are best).
 - b. Tie your glasses on.
 - c. Carry knife and waterproof matches (also compass and map).
 - d. Do not wear bulky clothing that will waterlog.
 - e. Wear a safety helmet when upsets are likely.
 - f. Carry an extra paddle and canoe repair tape.
 - g. Open canoes should have bow and stern lines (painters) securely attached. Use at least 15 feet of $\frac{1}{4}$ - or $\frac{3}{8}$ -inch rope. Secure them to the canoe so they are readily available but will not entangle feet and legs in case of a spill.
7. Swim on your back in fast water, keeping your feet and legs downstream and high. Keep watching ahead.

8. When you start to spill, keep the upstream gunwale high.
9. If you do spill, hang on to your canoe and get to the upstream end. (*Note:* If you are heading into rough rapids and quick rescue is not expected, or if water is numbing cold, then swim for shore or a rock where you can climb out of the water.)
10. When you are with a group:
 - a. Organize the group to even out canoeing ability.
 - b. Keep the group compact for mutual support.
 - c. Do not crowd rapids! Let each canoe complete the run before the next canoe enters.
 - d. Each canoe is responsible for the canoe immediately in front of and behind it.

INTERNATIONAL SCALE OF RIVER DIFFICULTY

The International Scale of River Difficulty provides a standard classification system for rating the difficulty and risks in running rapids. The scale is at best a rough estimate. It will vary depending on who does the evaluation, when the rating applies (spring runoff, summer low water, etc.), and the condition of the stream. Obviously, bank erosion, fallen trees, flood damage, and other factors can substantially affect the difficulty of a particular stretch of river within a short time.

Use the scale when planning a trip and selecting a river. Remember that the scale is useful only if you know and fully understand your own capabilities and limits and those of others who will participate in the river outing.

In addition, if the water or air temperature is below 50 degrees, or if the trip is an extended trip in a wilderness area, the river should be considered one class more difficult than normal.

When you get to the river and begin your run, the most important rating is your own—using your own eyes, ears, and good judgment.

The six classifications used for the International Scale of River Difficulty are as follows:

- | | |
|---|---|
| <p>Class I Moving water with a few ripples and small waves. Few or no obstructions.</p> <p>Class II Easy rapids with waves up to 3 feet, and wide, clear channels that are obvious with out scouting. Some maneuvering is required.</p> | <p>Class III Rapids with high, irregular waves often capable of swamping an open canoe. Narrow passages that often require complex maneuvering. May require scouting from shore.</p> <p>Class IV Long, difficult rapids with constricted passages that often require precise maneuvering in very turbulent waters. Scouting from shore is often necessary, and rescue difficult. Generally not possible for open canoes. Boaters in covered canoes and kayaks should know how to Eskimo roll.</p> <p>Class V Extremely difficult, long, and very violent rapids with highly congested routes that nearly always must be scouted from shore. Rescue conditions are difficult and there is significant hazard to life in the event of a mishap. Ability to Eskimo roll is essential for kayaks and canoes.</p> <p>Class VI Difficulties of Class V carried to the extreme of navigability. Nearly impossible and very dangerous. For teams of experts only, after close study and with all precautions taken.</p> |
|---|---|

EQUIPMENT

BOATS

Boats can have a wide variety of characteristics that affect their performance. The designs are continuing to evolve, primarily as a result of improvements in technology. Primary characteristics include depth, width, and rocker—the shape of the hull along the underwater keel line. (*If the craft lifts at its ends, then turning is made easier.*)

CANOES

Casual recreation canoes are generally built of “functional” materials with cost, low maintenance, casual storage, and safety as the primary considerations. Performance is not a primary consideration for these canoes. Boat length will vary.

Touring canoes are commonly called the traveler’s boat. They are long, slender, medium-volume canoes with low profiles. Speed is a primary consideration, and they measure about 17 to 18 feet long.

Downriver canoes are valued primarily for their directional integrity or fast straight-ahead paddling. They have a more sharply angled stern stem, which, along with minimal rocker, hinders their ability to turn. They are medium-volume canoes with significant depth and

are good performers in waters ranging from millponds to open bays to nontechnical Class II-III rivers. They tend to measure longer than 17 feet and have higher profiles than touring canoes.

Whitewater playboat canoes usually have a high degree of rocker; they are maneuverable, have high volume, and are fairly indestructible. They have greater durability rather than performance. They generally range from 16 to 17 feet long.

Decked canoes are closed canoes for two paddlers, and they resemble tandem canoes in length and waterline width. Cockpit placement can be linear (along an "imaginary" centerline) or offset.

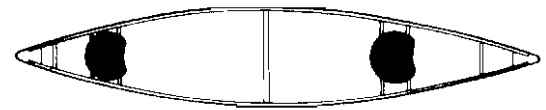

DOWNRIVER	
LENGTH	16½' TO 18½'
WIDTH	32"
WEIGHT	50 TO 60 LBS.

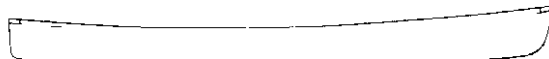
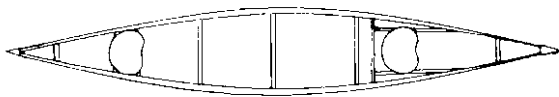

TOURING	
LENGTH	17'
WIDTH	33/31"
DEPTH	12½"

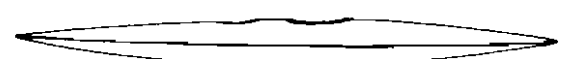
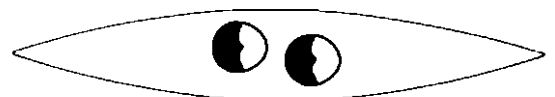

DECKED CANOE SLALOM C-2	
LENGTH	14'8"
WIDTH	2'7"
WEIGHT	33 LBS.

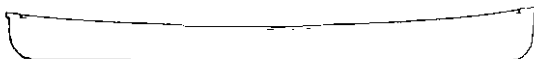

CASUAL RECREATION	
LENGTH	16'16"
WIDTH	34/33"
DEPTH	13½"

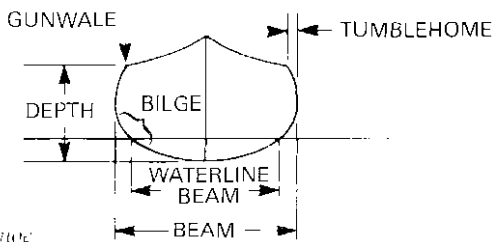
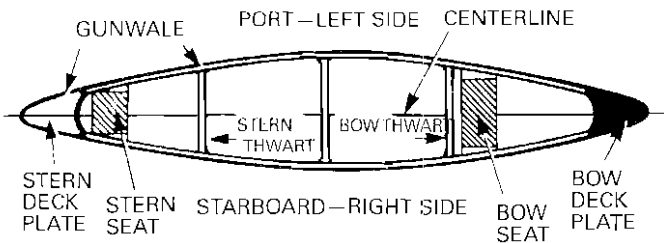
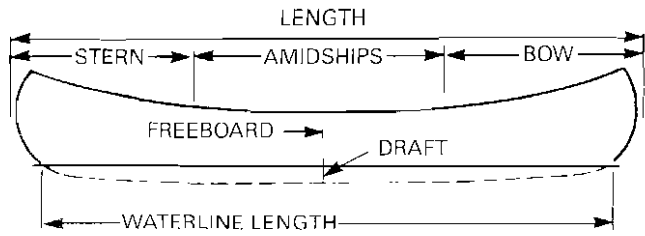

Parts of a Canoe

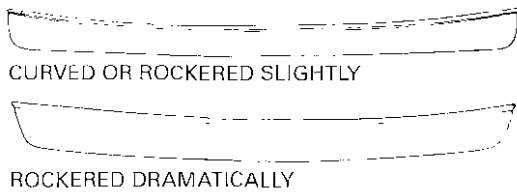

Canoe Rocker

KAYAKS

Casual recreation kayaks are primarily touring boats but will handle nicely in moderate whitewater of Class III or less. They are generally less than 15 feet long.

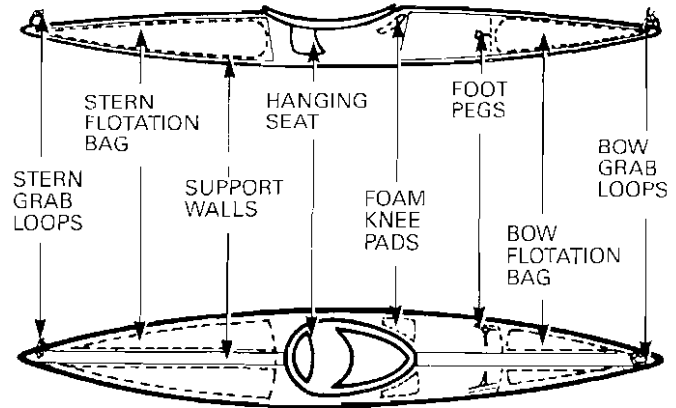

Parts of a Kayak

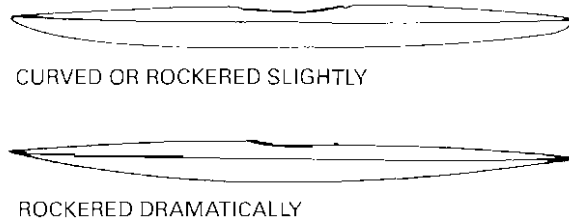

Kayak Rocker

Touring kayaks are very high-volume boats designed to carry generous loads of gear without compromising handling qualities on moderately rough waterways. Most have excellent directional stability, and many have high-peaked decks to shed water. They are fairly beamy (25 inches or more) and offer considerable stability. They tend to run 16 to 18 feet in length or up to 20 feet for touring doubles.

Whitewater playboat kayaks are medium- to low-volume boats and are built for one use—playing in rapids. They frequently have a great deal of rocker to aid in quick turns and “hot-dog” stunts. Most have relatively rounded sides to make them more easily handled while crossing strong eddy lines or surfing waves and holes. They are available in a wide range of lengths and volumes to match the size of the boat to the size of the paddler.

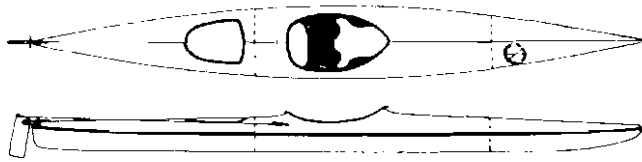

TOURING	
LENGTH	16'
WIDTH	23"
WEIGHT	14"

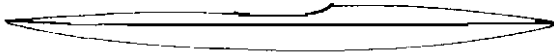

WHITewater PLAYBOAT	
LENGTH	13'2"
WIDTH	24"
WEIGHT	11"

PADDLES

The better whitewater paddles are made of hardwood or synthetic material with an aluminum shaft. Some paddles are molded entirely of fiberglass or plastic, but these are often too flexible for whitewater paddling.

The trend is toward shorter paddles, about chin-height for aluminum canoes (a few inches shorter for slalom canoes with their lower kneeling position and narrower hulls). Blades should be 7 to 8 inches wide. Narrower blades waste energy, and wider blades are clumsy. The grip should be rather square or T-shaped (not rounded) so that you can feel the exact angle of your blade. These paddle specifications are not rigid but depend on your physique and preference.

Double-blade paddles are recommended for kayaking. A double-blade paddle should have feathered blades, offset 90 degrees from each other. The offset blades will automatically feather on recovery as the opposite blade is used in the water. Double-blade paddles range in length from 80 to 85 inches. An 82- or 83-inch length is about right for a person 5 feet, 9 inches

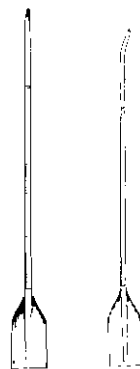

Double-Blade Paddles

tall. Two-part, jointed paddles are convenient for storage and transportation, but be sure the joint is well-fitting and secure. Jointed paddles are not as sturdy as their one-piece counterparts. Double-blade paddles may have either flat or spoon blades, but the flat blade is preferable for the beginner.

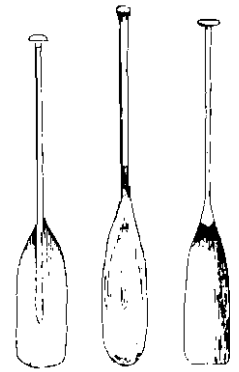

Single-Blade Paddles

Paddles may have one side of specific paddle control. "Right-hand" or "left-hand" control indicates that the designated hand maintains a firm grasp on the paddle and controls the angle of the blades. The other hand permits the shaft to rotate within the grasp between strokes but holds the paddle firmly during the stroke.

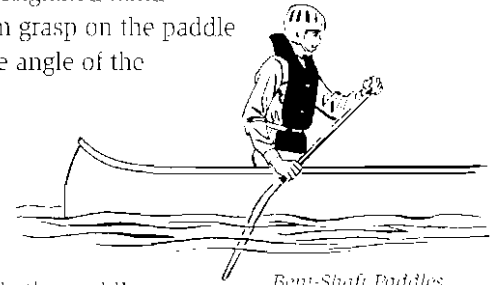

Bent-Shaft Paddles

A kayaker can determine the type of hand control by examining the power face of the blade. If a kayaker takes a power stroke on the right side of the craft and the power face of the opposite blade is facing up, then he has a "right-hand" control paddle.

PARTS OF A PADDLE

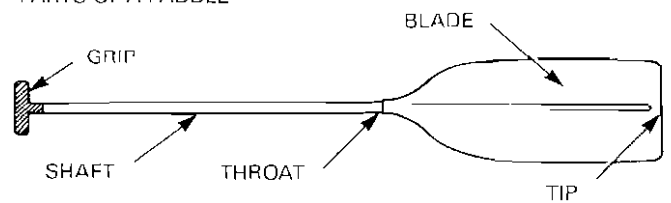

CANOE

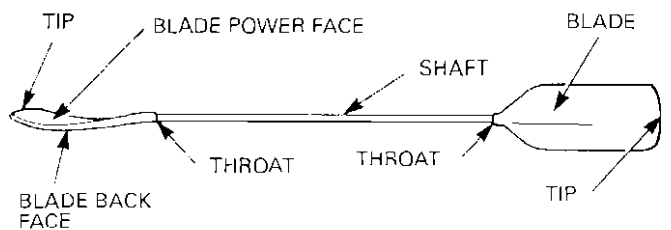

KAYAK

Paddles are constructed of wood, fiberglass, plastic, and aluminum. Paddlers' needs will determine their choice of paddles. Higher-performance paddles are lighter and more expensive but sometimes less durable. Paddles used on rugged, remote trips can be heavier and more durable. Aluminum shafts may feel cold to bare hands.

PADDLING TECHNIQUE

Paddling is most enjoyable when it is done efficiently and under control. The technique generally involves efficiency in three separate areas: (1) body movement, (2) placement of the paddle in the water, and (3) placement of the boat in the river. Let's examine the first two areas.

BODY MOVEMENT

Efficient body movement means learning to use the larger muscles of the body to propel the boat. In paddling, the arms are connectors to the real source of power—the torso. The rotation of the torso around the spine provides the power for all strokes rather than the push-pull motion of the arms. The power from the torso is transferred to the boat through the contact points of the feet, knees, and hips. This use of the whole body, which emphasizes the larger muscle groups of the shoulders, back, and thighs, gives the paddler more energy to accomplish the paddling maneuvers.

FORWARD STROKE ILLUSTRATING BODY ROTATION

Purpose: To use the entire power unit—body and arms—to minimize shoulder dislocations.

1. The paddle begins its recovery.



2. The paddler leans slightly forward as the recovery continues.

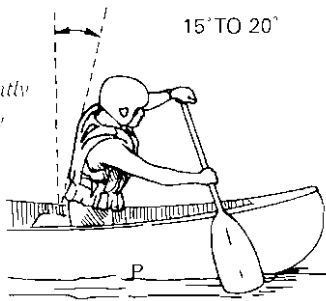

3. The torso rotates to allow a good windup before the paddle is planted.

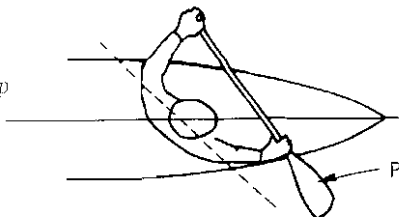

Recovery phase illustrations 1-3
Force applications illustrations 4-6

A significant benefit of using body rotation in paddling is that it helps keep the shoulder joint in a position that minimizes the chance for a shoulder injury. This commonly happens when the boat tips or turns over.

PLACEMENT OF THE PADDLE IN THE WATER

Efficient paddle placement includes several factors. The first can be called the "paddle in concrete" analogy. When the blade is placed firmly and completely in the water, it will seem almost as solid as putting it in concrete.

The second factor to remember is that, in moving the boat forward or backward, the part of the stroke where the paddle is vertical is the most effective. The longer the vertical phase of the stroke, the more the boat is moved on any given stroke.

A third factor influencing forward and backward boat movement is that the closer the blade is to the midline, the straighter the boat will travel. Practically, this means a vertical paddle for canoeists and an almost vertical one for kayakers.

4. The paddle is planted with a more vertical shaft position (70 degrees to water surface).

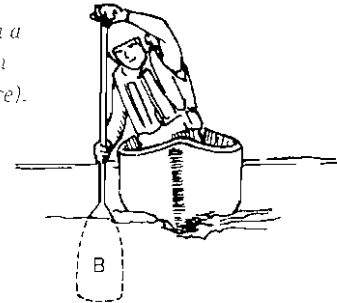

5. The paddler applies power by unwinding the torso

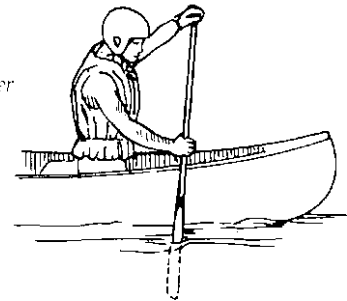

6. The stroke ends before the paddle passes behind the body. Note the range of torso rotation through the stroke.

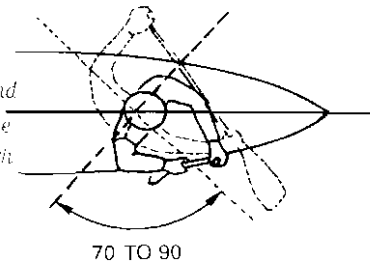

The fourth factor to remember is that the closer a turning stroke is to the ends of the boat, the more efficient it is for turning the boat.

EFFICIENT PADDLING TECHNIQUE

There are three stages of a stroke: catch, propulsion, and recovery. The forward stroke is the most frequently used stroke; we'll use it to begin our discussion of the steps in an efficient paddling technique.

- 1. Catch.** If paddling on the right, rotate your shoulders so that the right shoulder is pointing toward the bow of the boat and the left is pointing toward the stern. Your torso is wound up, your arms should be relatively straight, and you should lean slightly forward. Then plant the paddle. That is, push the paddle down into the water with your control hand. *Hint:* Your control hand should be out over your shaft hand (both hands out over the water, with the paddle shaft vertical). (If the control hand is inside the boat, the stroke becomes a turning stroke.)
- 2. Propulsion.** Begin to unwind your torso, keeping your arms relatively straight, the paddle shaft vertical, and your control hand over your shaft hand.
- 3. Recovery.** To recover, as the blade reaches your hips, drop your control hand slightly to the left, just enough to let the blade slice out of the water. Your control hand should not drop below chest level as the blade is sliced out of the water and feathered forward. If your shoulder rotation is correct, your arms are relatively straight and your control hand has not dropped below chest level. Your control hand should be drawing clockwise circles (about 6 to 12 inches in diameter) out in front of you. Rotate your shoulders again, with your right shoulder toward the bow. You are then ready for another catch.

The stroke stops before the paddle passes behind the body. Shorter strokes are more effective since the majority of power comes from unwinding the torso. Slicing the blade out of the water keeps it from lifting up on the water and pushing the boat down.

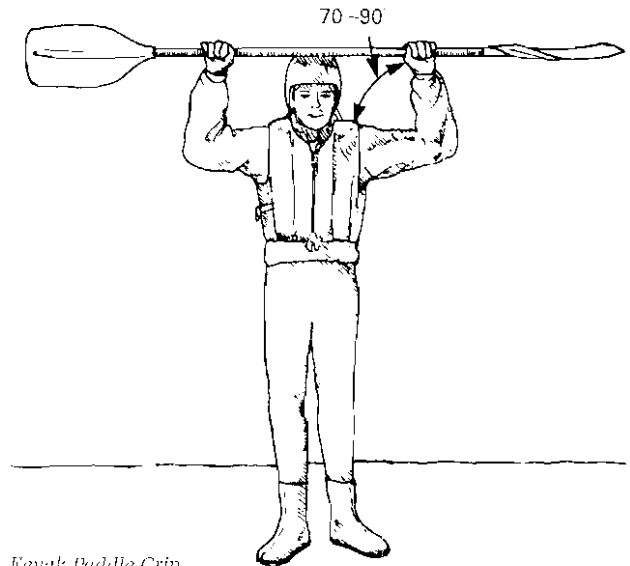

Kayak Paddle Grip

Note: Kayakers grip the paddle in the palm of their hands rather than the fingers. The paddle is gripped in this manner so that, during a forward stroke, the upper hand is no higher than the head, while the lower hand skims the water. As an extra help, beginners should tape the proper grip location on the paddle.

MANEUVERS

There are three primary types of strokes: power, turning/corrective, and bracing. Paddling maneuvers for each craft are illustrated below and specific strokes that can be used to execute the maneuvers are described. The maneuvers include:

- Spins
- Forward straight
- Reverse straight
- Sideslips or shifts
- Eddy turns and peelouts
- Bracing
- Ferries
- Rolling

Various combinations of strokes are illustrated for each maneuver to show the many ways that paddlers can perform a given move. The choice of strokes often depends upon the paddlers' comfort with particular strokes and the nature of the body of water. Some strokes will work more efficiently in flatwater (i.e., pushaway), while others will be more appropriate for current (i.e., Duffeks).

TYPES OF STROKES

POWER

Forward Power Strokes. These strokes are used for propulsion, not correction; the power face (P) is used in the execution of each stroke.

Reverse Power Strokes. These strokes are used for propulsion, not correction. Different power faces are listed for the various strokes.

TURNING/CORRECTIVE

On-Side Strokes. These turning strokes move the boat (solo) or the portion of the boat in which the paddler is located (tandem) toward the “on” side of the paddler. For instance, the strokes move the canoe toward port (left), if the canoeist’s selected paddling side is port. All strokes use the power face (P) unless indicated otherwise.

Off-Side Strokes. These turning strokes move the boat (solo) or the portion of the boat in which the paddler is located (tandem) toward the “off” side of the paddler. These strokes move the canoe away from the paddler’s selected paddling side. The blade face differs for the various strokes.

Strokes to Maintain a Straight Course. These turning strokes are used to maintain a straight course forward or backward. They are executed in the “following end” (cddy-resistance end) of the craft. The blade face differs for the various strokes.

BRACING

Bracing Strokes. These strokes maintain an upright and stable craft. The blade face used varies.

The maneuvers for canoeing are divided into “on-side” and “off-side” moves rather than “left” or “right” maneuvers. The intent is to enhance communication between paddlers and the instructor in introducing the maneuvers and to help tandem paddlers communicate more effectively on the river.

The point of reference is the selected paddling side of the tandem bow paddler (the side of the boat where they execute forward strokes). For instance, an *on-side* eddy turn or peelout means that a boat is turning *toward* the tandem bow canoeist’s paddling side. An *off-side* eddy turn or peelout refers to a canoe turn *away* from the paddlers’ selected side.

DESCRIPTIONS OF STROKES

BACKSTROKE

The backstroke begins with the blade of the paddle reaching back and entering the water behind the paddler with the blade flat to the surface of the water. The body of the paddler should rotate toward the paddling side with the grip out over the water and the upper arm extended. Plant the paddle in the water, just behind the hips. As you begin to unwind the torso, keep your control arm relatively straight and your shaft arm slightly bent; keep the paddle shaft vertical and your control hand over your shaft hand. To recover, as the blade reaches your knees, drop your control hand slightly toward the keel line, just enough to let the blade slice out of the water. Rotate your shoulders again to get ready to plant the paddle for another backstroke, if necessary.

COMPOUND BACK

Rotate your shoulders toward the on-side. They should be parallel to the keel line. Turn your control thumb toward the keel line. Plant the paddle aft of your feet. As your torso unwinds, the blade comes to your hips. At this point, quickly point the control thumb away from the keel line. Finish the power phase by pushing the paddle away from you and toward the bow. The stroke ends at the knees. To recover, follow the instructions for the standard backstroke.

FAR BACK

The far back is simply the first half of the compound back. Follow steps 1 and 2 for the catch and propulsion phases. The recovery for the far back can be either top-water or underwater recovery, with the latter being more efficient. Simply rotate the control thumb toward the stern and slice the blade back through the water to the catch position.

CROSS BACK

This stroke is used only in the bow of a tandem canoe or by a solo paddler. To begin, rotate your shoulders away from on-side. Plant the paddle near your feet. The control thumb should be pointing away from the keel line. As your torso unwinds, the paddle will move toward your knees. Keep the paddle shaft vertical and the control hand over the shaft hand. As the paddle reaches your knees, either (a) drop the control hand back toward your shoulder to lift the blade out of the water or (b) turn your control hand toward the bow and slice the blade back toward the stern to catch another cross-back stroke. The underwater recovery is recommended.

TABLE 1				
In the following listing, the side of the blade used to apply the force is not the same for all strokes. The differences are noted by the use of these symbols: power face (P) and back face (B). The <i>power face</i> is the side that is pressed against the water during a forward stroke. <i>Back face</i> refers to the reverse side of the blade; it is pressed against the water during a back stroke.				
Stroke Type	Tandem Bow Canoe	Tandem Stern Canoe	Kayak	Solo Canoe
Forward Power	Forward Cross Forward	Forward	Forward	
Reverse Power	Back (B) Compound Back (P to B) Far Back (P) Cross Back (P)	Back (B) Compound Back (P to B) Far Back (P) Cross Back (P)	Back (B)	
On-Side	Draw Stationary Draw Reverse $\frac{1}{4}$ Sweep (B) Duffek (Draw to bow)	Draw Stationary Draw Forward $\frac{1}{4}$ Sweep Shallow Water Draw	Draw Stationary Draw Duffek	
Off-Side	Pushaway (B) Stationary Pry (B) Pryaway (Dynamic) (B) Forward $\frac{1}{4}$ Sweep (P) Cross Draw (P) Cross Duffek (P)	Pushaway (B) Stationary Pry (B) Pryaway (Dynamic) (B) Reverse $\frac{1}{4}$ Sweep (P) Reverse Duffek (P) Rudder (P or B) Shallow Water Pry (B) Reverse Sweeping Low Brace (B)	Draw Stationary Draw Duffek	Pushaway (B) Pryaway (Dynamic) (B) Cross Draw (P) Cross Duffek (P)
Bracing	High Brace (P) Low Brace (B) Turning Braces (high P and low B)	High Brace (P) Low Brace (B) Cross Low Brace (B) Turning Braces (high P and low B)	High Brace (P) Low Brace (B)	
Strokes to Maintain a Straight Course	“Following end” is stern “J” Stroke (P) Slice “J” (P) C Stroke (solo only) (P) Ruddering (P or B)	“Following end” is bow” Reverse “J” (B) Reverse “J” Modifications Ruddering	Kayaking Forward Sweep (P) (if moving forward) Reverse Sweep (B) (if moving backward) Ruddering (B)	

DRAW

This on-side stroke makes the canoe move sideways toward the paddling side. When done correctly, there is no turning. The canoe tends to lean toward the paddling side when the draw is done.

Begin the stroke with the paddle entering the water at full reach, straight out from the paddler and with the blade parallel to the keel line. The paddler's body is rotated toward the paddle side, with the lower arm extended and the upper arm high and out over the shaft hand. The arms stay relatively straight and the paddler pulls the boat toward the paddle by raising his torso back over the keel line. The paddle should remain nearly vertical throughout the stroke. The stroke ends before the paddle hits the side of the canoe.

Recovery begins when the paddle is about 6 inches from the side of the canoe, with the upper arm extended out over the water and the bent lower arm near the side. For the feather and recovery, slice the blade out of the water toward the stern by lowering the grip hand, or feather through the water directly to the start of a new stroke by rotating the paddle 90 degrees and slicing straight out through the water with your control thumb pointed away from the keel line. The drawstroke moves the canoe sideways because the paddle pushes water under the canoe, so keep the paddle deep. If you are splashing water against the side of the canoe, you are losing power.

STATIONARY DRAW

This stroke is used when the canoe is moving faster than the current. Slice the blade in next to the canoe and hold it braced against the canoe. The control thumb should be pointing toward the direction you want the canoe to go. The blade is usually at a 45-degree angle to the keel line. The canoe should move to the on-side.

REVERSE ¼ SWEEP (B)

If you are in the bow, plant the blade out from the hips with a horizontal paddle shaft, control thumb pointing upward. Sweep the blade in an arc toward the bow of the boat. Your control hand will move in toward the shoulder of your shaft hand and your shaft arm will stay relatively straight as it reaches toward the bow of the boat. Drop your shaft hand to lift the blade out of the water.

If you are in the stern, plant the blade next to the stern of the boat (use shoulder rotation to get the blade to the stern). The control thumb should be pointed upward, with the paddle shaft horizontal. Rotate your shoulder by unwinding your torso. The stroke ends when the paddle reaches the area opposite your hips. Drop your control hand. This will, in turn, lift the blade out of the water.

DUFFEK (DRAW-TO-BOW)

This on-side stroke is a tandem bow and solo stroke only. Rotate your shoulders so that they are parallel with the keel line on the boat. Plant the blade at a 45-degree angle from the bow. Shift your weight slightly to the on-side knee. The paddle shaft should be vertical, with your control hand over your shaft hand. Rotate the knuckle of your control thumb toward you. Your control arm should be positioned so that you could look at an imaginary wristwatch. Your shaft arm is slightly bent, with your elbow pointed toward your navel. Your arms should be locked into this position. The power face is pointed toward the bow.

As your torso unwinds, lean slightly forward. The blade should be moving toward the bow. This acts as a stopper; that is, when catching an eddy, the boat spins around the Duffek stroke. It is very important that the paddle shaft remain vertical, as this also acts as a bracing stroke.

For recovery, (a) drop the control hand toward the keel line or (b) rotate the control thumb away from the keel line. You are now in a position to go into a forward stroke, i.e., to pull the boat up into the eddy now that you have spun around in the eddy.

FORWARD ¼ SWEEP (P) (Torso rotated toward off-side.)

Bow. Plant the blade next to the bow of the canoe, with your control thumb pointed upward. Lean slightly forward. The shaft should be horizontal, with your control arm bent and your elbow tucked in toward your navel. Your shaft arm should be straight and extended toward the bow.

As your torso unwinds, maintain your hand and arm positions and let your torso do the work. The blade should sweep out in an arc and stop when opposite your hip.

For recovery, drop your control hand down, rotate the control thumb toward the bow, and rotate your shoulders again to off-side to arrive at the catch position again.

Stern. Plant the blade opposite your hip with your control thumb pointed upward and the shaft horizontal. Your control hand is low and your elbow bent. Your shaft hand should be extended.

Rotate your shoulders toward the on-side, as the blade nears the stern, and extend your control hand out and pull the shaft elbow in behind your torso. This action will pull the blade all the way to the stern, where the greater turning power lies.

To recover, drop your control hand, rotate your control thumb away from you, and rotate your shoulders back to their original position. You should now be in the catch position again.

PUSHAWAY (B)

The opposite of the drawstroke is the pushaway. This stroke moves the canoe sideways, away from the paddling side. The canoe tends to lean toward the paddling side when the push is applied. When the pushaway is done correctly, there is no turning.

For the pushaway, the paddle enters the water very close to the canoe and right beside the paddler. The blade reaches slightly under the bilge to begin the stroke. The upper arm is extended out over the water, while the lower arm begins the stroke in a bent position close to the body. The stroke is made by pushing the blade away from the canoe in a line perpendicular to the keel line. The blade is parallel to the keel. The upper arm and shoulder pull in toward the body as the lower arm swings and pushes. The stroke ends when the lower arm is fully extended.

The recovery is done either by feathering the blade out of the water and swinging it in an arc toward the stern and back to the catch position, or by rotating the blade 90 degrees at the end of the stroke and slicing through the water in a straight line back to the catch position. The underwater recovery is usually faster and less awkward for this stroke. The pushaway moves the canoe sideways by pulling water from under the canoe, so remember to reach under and keep the paddle deep.

STATIONARY PRY (B)

This stroke is used when the canoe is moving faster than the current. Slice the blade in next to the canoe and hold it braced against the canoe at a 45-degree angle to the current. The control thumb should be pointed away from the direction you want the canoe to move. The shaft should be vertical. The canoe should move to the off side.

PRYAWAY (DYNAMIC) (B)

This stroke moves the portion of the boat in which the paddler is located toward the paddler's offside. It is used primarily in moving water. The bowman will plant the blade just in front of him while the stern paddler would plant the blade just behind him.

Your control thumb is pointed toward the stern and out further over the water than the shaft hand. This places the blade farther under the boat and gives the paddler more "purchase" (more water to pull against). The shaft hand can rest on the gunwale and use it as a fulcrum. Pull the control hand toward the centerline of

the boat (in front of your chest), leaving your shaft hand on the gunwale "fulcrum."

An underwater recovery is more efficient in the bow. Turn the control thumb out away from you. Slice the blade back underneath the boat by moving the control hand back out over the water.

Topwater recovery is more efficient for the stern. Leave the shaft hand on the gunwale and drop the control hand down to lift the blade out of the water, then move the control hand back out over the water.

CROSS DRAW (P)

Bow and solo only. Rotate your shoulders to off-side. They should be parallel with the keel line. The shaft will be horizontal. Your control thumb is pointed upward and your elbow is tucked into the side. Shift your weight slightly to the off side knee. Your shaft arm is extended. The blade should be planted at a 45- to 60-degree angle from the bow.

In the propulsion stage, as your torso unwinds, the blade moves toward the bow, thus turning the boat. In recovery, (a) drop your control hand, which in turn lifts the blade out of the water, and rotate your shoulders back to the catch position or (b) rotate your control thumb toward your torso, rotating your shoulders back while slicing the blade through the water.

CROSS FORWARD (P)

Bow only. Begin this stroke by grasping the paddle as if ready to do a forward stroke. Now, without changing your hand position, move the paddle to your off-side. Lean your torso forward at the waist about 15 degrees. Plant the paddle vertically in the water.

Keeping arms relatively straight, rock your torso back to a sitting position. Then rotate your control thumb forward, leaving the blade in the water, with your arms still relatively straight. Then rock your torso forward again about 15 degrees. You should now be back at the catch position.

For stern and solo positions, this stroke can be used for eddy turns and peelouts.

CROSS DUFFEK (P)

Bow and solo. To catch, rotate your shoulders to the off-side. Shift your weight slightly to your off-side knee. The paddle shaft must be vertical. Your control arm is straight and your control hand is over your shaft hand. The control thumb is pointed away from your body. The blade is planted at approximately a 45-degree angle from the keel. The blade must be away from the boat.

As your torso unwinds, the paddle should move toward the bow (lean forward slightly), with your arms staying in position (paddle shaft vertical).

To recover, there are a couple of options. (A) As the paddle nears the bow, rotate the control thumb toward the on-side. You are now in a position to do a cross-forward stroke to, for example, pull the canoe up in the eddy. (B) Rotate the control thumb toward the on-side. Then rotate the shoulders to the off-side and slice the blade through the water back to the catch position.

REVERSE SWEEPING LOW BRACE (B)

Rotate your shoulders toward the on-side so that they are parallel with the keel line. Plant the paddle at the beginning of a reverse sweep; with the shaft horizontal, your control hand low, and your control thumb up. Keep the blade next to the stern of the canoe. Keep your weight on your on-side knee, with your off-side foot braced into the canoe seat. Keep your control hand low and over the water, not the gunwale, as you begin the reverse sweep. Your control thumb should rotate toward the bow so that the blade is skimming across the top of the water at a climbing angle. Both hands should be out over the water; you may need to choke up on the paddle with your shaft hand. To recover, slide your head and control hand back in over the center of the canoe, keeping your head low over your control hand.

TANDEM CANOEING MANEUVERS

Tandem canoeing is a cooperative venture, and the challenge in the sport is more than just learning the maneuvers. Working well with a partner is an integral part of successful tandem paddling. Effective communication is necessary between partners so they can understand their roles in their respective ends of the canoe and work together to paddle the boat. Tandem paddlers need to understand:

- The complementary bow and stern strokes that, when used together, form the basis of all maneuvers.
- The reaction of each end of the craft when a specific stroke is executed.
- The reaction of the craft as a whole when a stroke is used.

Neither paddler should switch sides indiscriminately. Each person should paddle on the side opposite that of the partner to balance the craft.

The paddler in the “following” end of the canoe (usually the *stern person*) has a responsibility to:

1. Follow the proper general course in the river (i.e., river center, left, or right) by choosing a route with the other paddler.
2. Maintain the craft’s alignment parallel to the current (this is easiest if done in the “following” or “eddy-

resistance” end of the canoe), or change the alignment to set up a particular move.

3. Maintain adequate spacing relative to other craft.
4. Assist upstream canoes by pointing at the proper course.
5. Relay messages up- or downriver.

Paddlers in the “leading” end of the canoe, most often the bow, have a responsibility to:

1. Read the immediate route in the river.
2. Decide the appropriate strategies and maneuvers and communicate these decisions to their partners.
3. Take immediate action to execute the strategy for negotiating the river in anticipation that partners will follow their lead.

Maneuvers: Spins

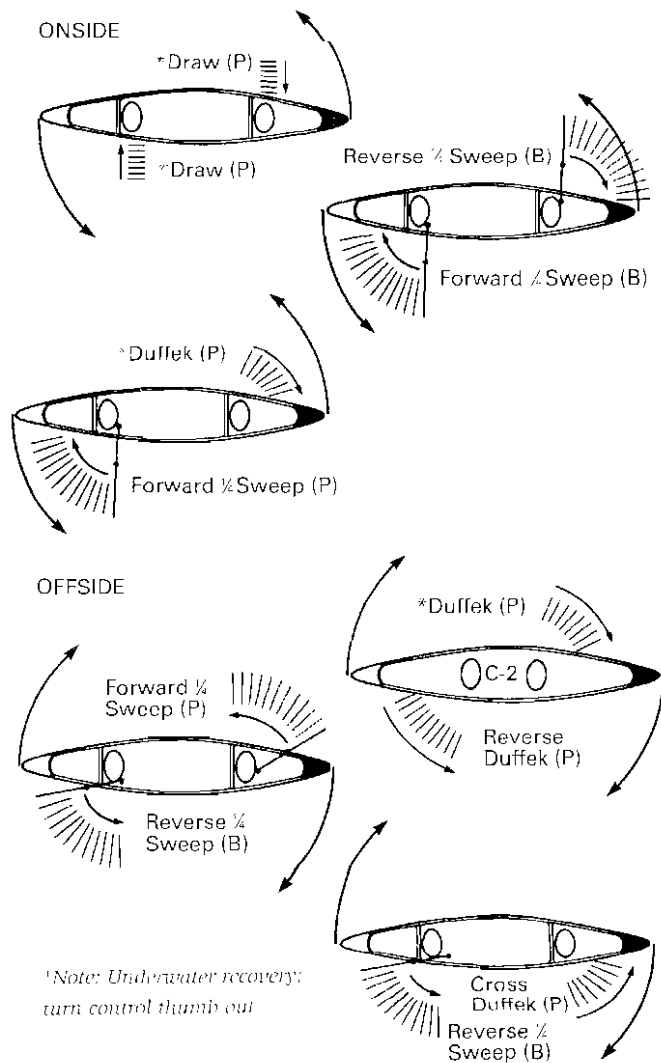

Maneuver: Forward Straight

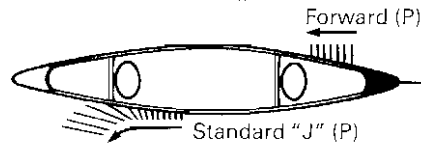

Maneuver: Reverse Straight

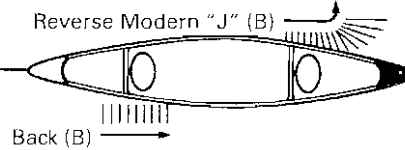
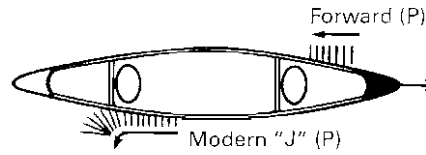
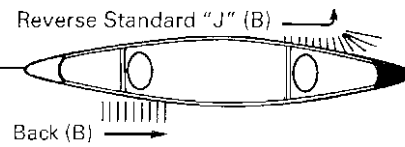

Maneuvers: Slideslips (Shifts)

ONSIDE

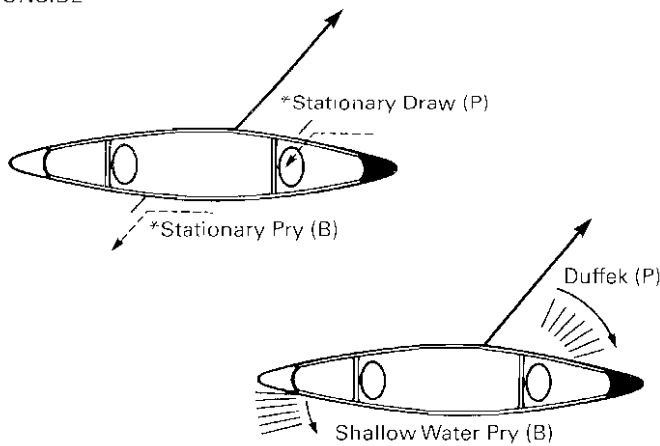

OFFSIDE

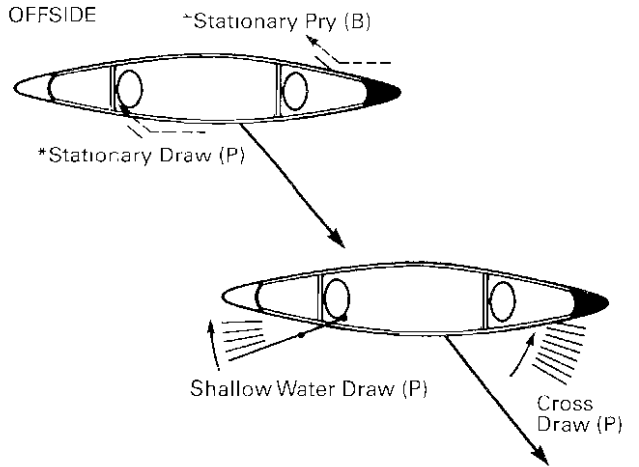

*Note. These static strokes require that the craft be moving faster than the current

Maneuvers: Turns

ONSIDE

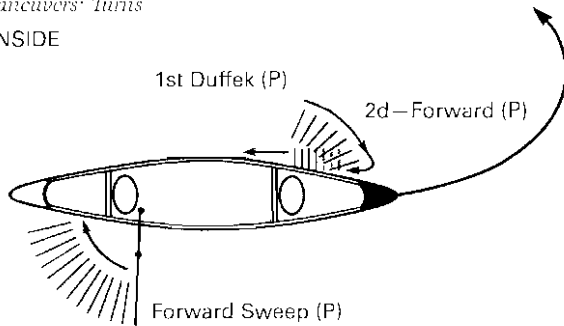

OFFSIDE

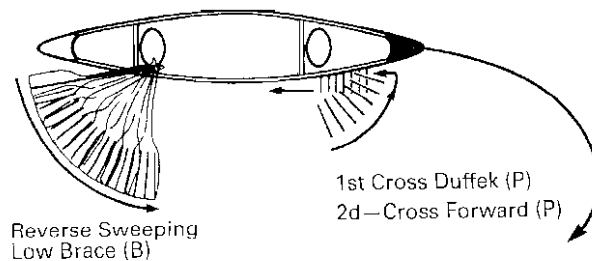

U-Turns

- Develop entering momentum at position 2.
- Begin the initial torque at position 3.
- Must lean downstream to the entering current as soon as the "entering end" of the boat crosses the eddy line.
- A turning brace (i.e., Duffek) is placed in the entering current. This brace should initially broach the entering current. If entering the eddy high, this means the power face is almost at a right angle to the boat since the entering current is flowing out (see dark arrow above).

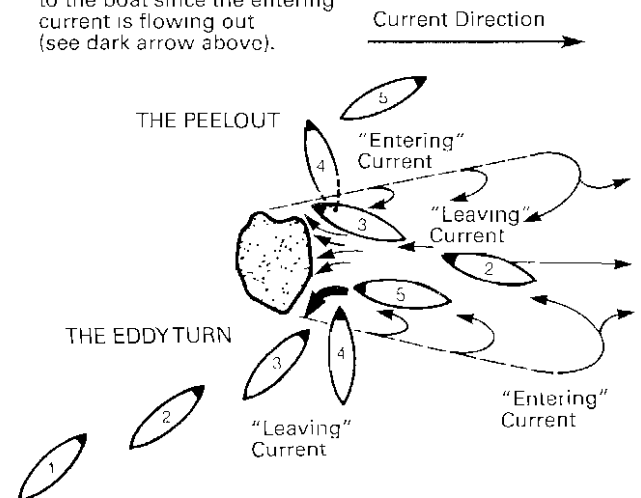

Maneuvers

OFFSIDE EDDY TURN

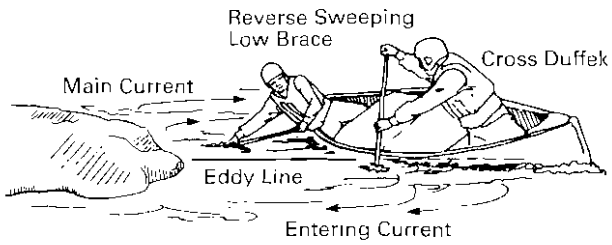

OFFSIDE PEELOUT

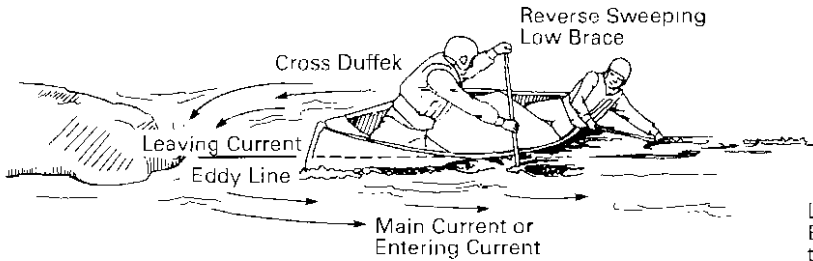

ONSIDE EDDY TURN

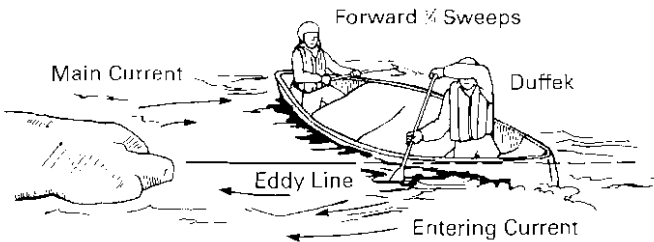

ONSIDE PEELOUT

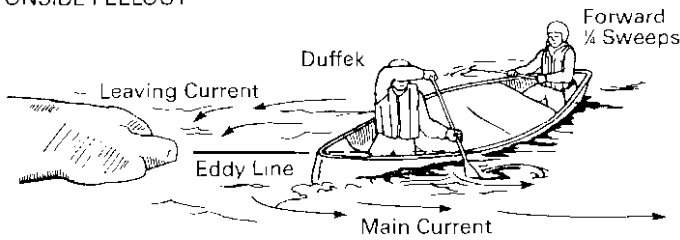

Maneuvers: Bracing

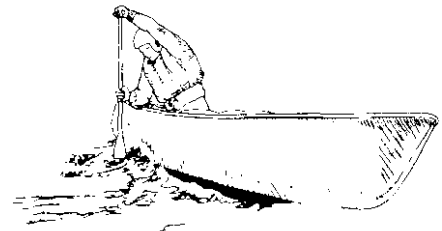

HIGH BRACE
The paddle remains in the water with a dynamic high brace draw, which stabilizes the boat.



LOW BRACE
Both hands remain low and outside the boat for an effective low brace. The control hand may be lower as long as the hip snap is initiated with the blade near the water surface.

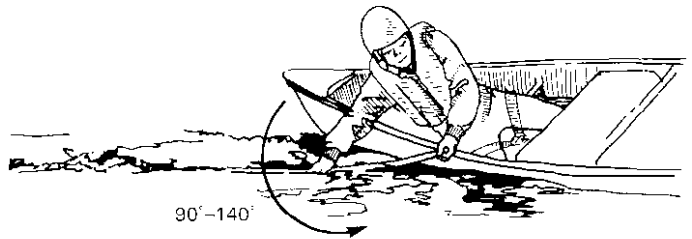

REVERSE SWEEPING LOW BRACE
Both hands remain low as the paddle sweeps from the stern, past a point directly opposite the hip. The brace is usually converted quickly to a forward stroke somewhere beyond 90° from the stern.

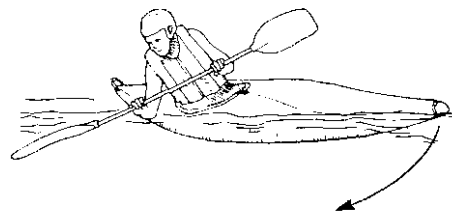

THE "LOW" HIGH BRACE
Kayak paddlers often use a "low" high brace, especially when entering the fast main current from an eddy. The brace is placed with the shaft at right angles to the boat about 8 inches in front of the paddler. The paddler reaches out as far as possible and places the power face on the current. The edge of the blade nearest the bow should be slightly elevated (a climbing angle) to prevent the blade from diving and to allow a "low" sweep to the bow for a more crisp turn.

Maneuvers: Kayak Rolling

THE SETUP
Wrist cocking of hand nearest the bow at the setup.

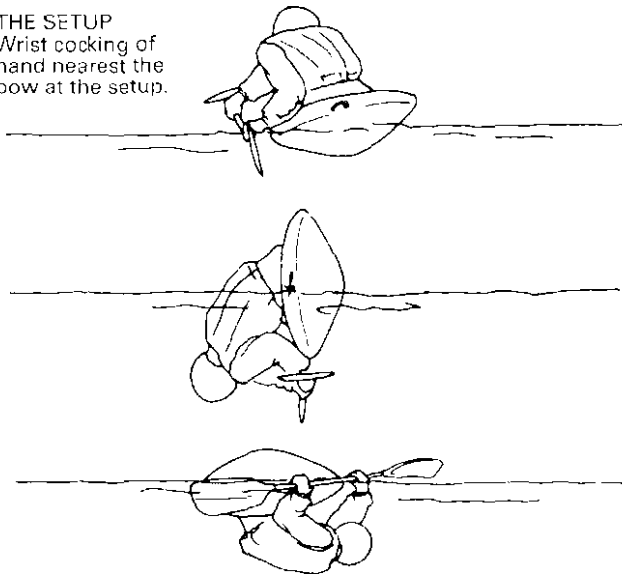

THE HIP SNAP
Begin the hip snap as the paddle blade sweeps out to 90 degrees. The boat should be upright when the paddle reaches 90 degrees. The hands do not move behind the upper body plane.

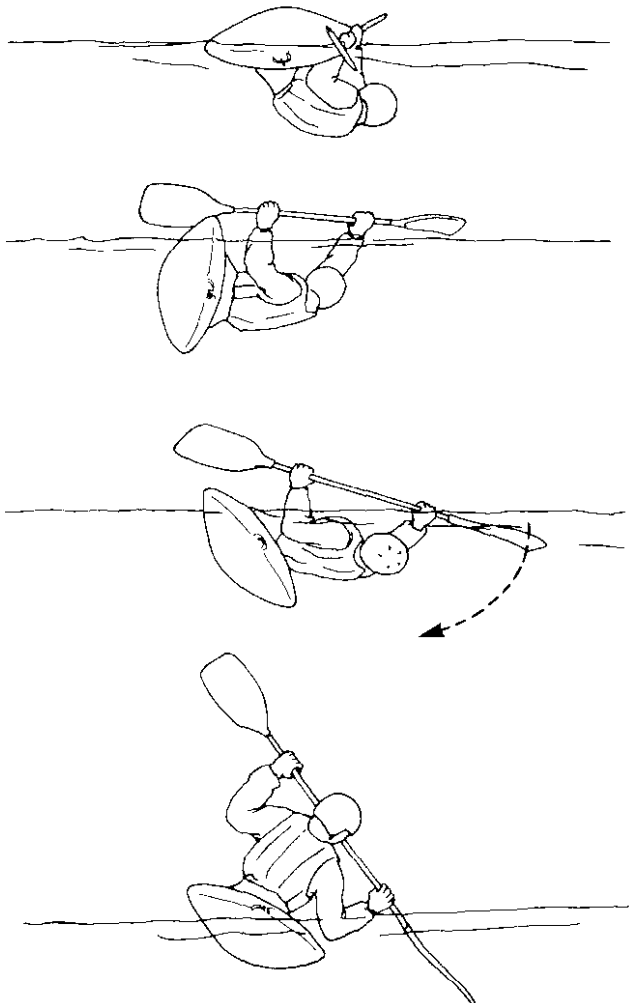

Maneuvers: Ferries

FORWARD FERRY

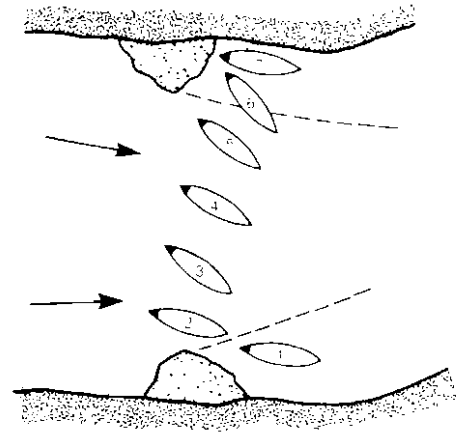

BACK FERRY

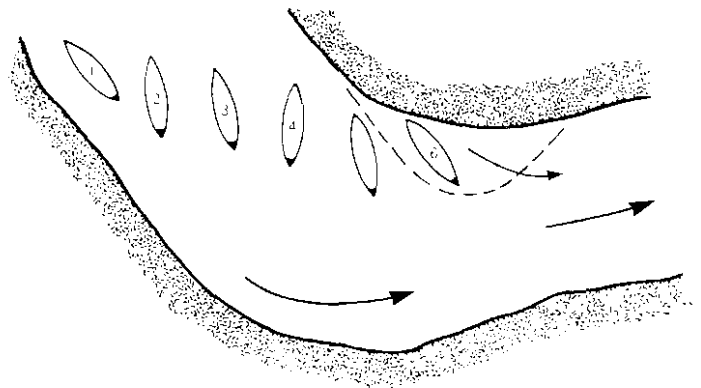

FUNDAMENTALS OF RIVER READING

Before setting out on running water, you must understand and recognize what the water is doing, what is hiding under the water, and what the water—and whatever is in the water—can do to you.

Current within the river is a function of the geology around and in the river. The contours of the riverbed and obstacles within it force current to move in various directions. If the geology of an area is primarily jagged ledges with steep contours, then the character of that river will be very different from a river that meanders through farmland in a wide valley.

Current direction is generally parallel to the banks. In a turbulent rapid, learn to sight obstacles, such as rocks, waves, bridge piers, or tips of fallen trees, against the background. When the water meets a solid ledge, it is turned aside, and that water will help to carry you canoe clear also. However, when the water goes on through the obstacle, beware. Sometimes it is pouring over a ledge or dam, and you must be careful you are not swept over, too.

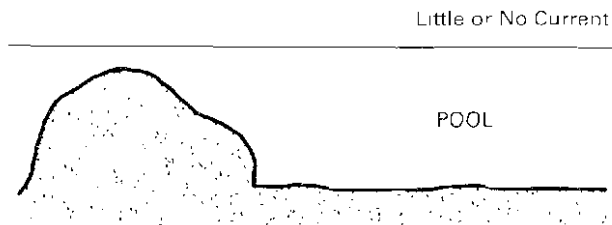

A Pool

Obstacles can be hidden just beneath the surface.

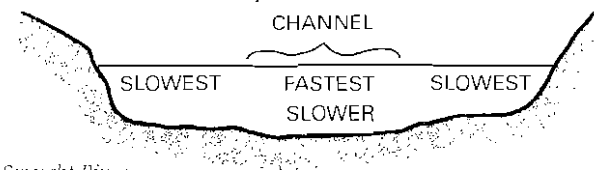

Straight River

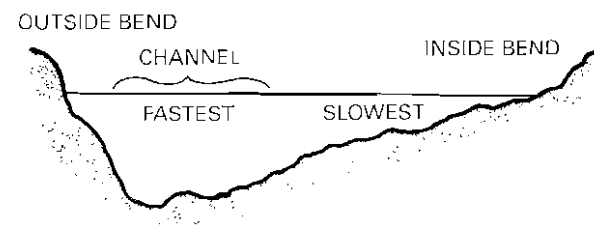

River Bend

Only real experience and observation will make you a good "river reader," but there are some common signs you can look for when you approach an unfamiliar stretch of river.

Eddies. Extreme cases of current differentials are called *eddies*. Behind a large rock, the current may be entirely still or even flowing gently upstream, although right beside the rock, the main current rushes by at full speed. Here the current differential is abrupt. You will hear it called the *eddy line* or even the *eddy wall*.

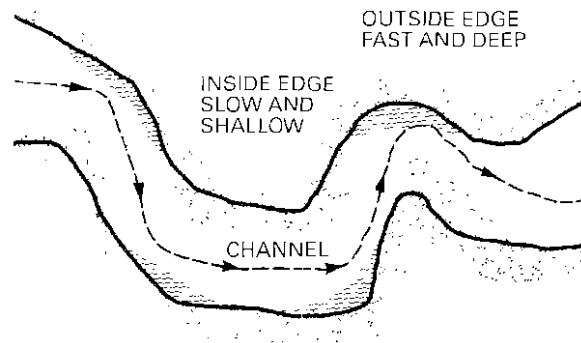

The channel flows to the outside of the riverbends and often bounces away from the bank in irregular patterns

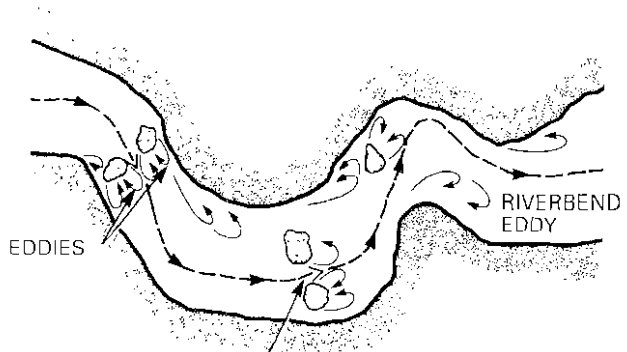

Downstream Vs mark the channel between obstacles.

Rocks. Although rocks can be more damaging in swift water, they are also easier to spot and waves can reveal their hiding places. If the rock is close to the surface, the water follows the contour of the rock as it pours across, and a raised convex pillow appears on the surface. If the rock is deeper, the surface wave appears further downstream and you should be able to go over the rock without touching it.

Souse Hole. Beware. As the current becomes swifter, the pillow over the rock will be followed by one or more scalloped standing waves, which are much easier to spot than the pillow. The **souse hole** appears behind the pillow in very powerful currents. Even when you can run over the pillow, the canoe may not be able to climb out of the souse hole unless it has full forward speed (and perhaps a full splash cover).

Open (Upstream) V. This is the canoeist's friend. Rocks on both sides or a break in the ledge let the current through in a "swoop." An open V is noisy, with a rushing sound. A "haystack" (big waves showing deepening channel) may appear below the V. They are rough. If they're small, OK; if not, skirt the edges, and then bail.

Closed (Downstream) V. This V points into the current and is dangerous. It is caused by a shallow rock or log and is a real canoe-buster. A closed V is not hard to steer around, if you see it in time. You probably won't hear it because there is too much other noise. Rocks are rarely visible to the canoeist. Watch out for pillows and look for standing waves.

Waves. It is the standing waves or "haystacks" that mark deep water and are the greatest delight of the canoeist. They may be spotted by their characteristic scalloped shape and long length and by the fact that they appear in groups, usually a half dozen or more spaced at regular, downstream intervals. Continue through the waves if they are not so big as to swamp you; otherwise draw to one side when free of the obstacles and run the waves where they are small.

When you are in rough and turbulent water and spot a quiet area, avoid it like the plague. As you shoot past, sneak a look back and you will see that a hidden rock with water pouring over it protects the quiet spot. Survey the area from the shore and you can often see rocks clearly from the side and from below, although they are quite invisible from the approaching canoe.

Dams and Ledges. Dams and natural ledges create the most hazardous river situations. As water pours over the dam or ledge, it hits the bottom and recirculates creating a foamy, aerated boil. This phenomenon is called a *hydraulic*. Dams and ledges may be recognized from upstream as a solid line across the river. Land far enough above to prevent being swept over, and survey the scene.

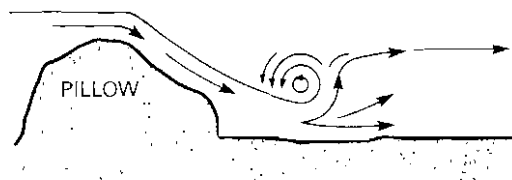

CURRENT AT LOWER WATER

Small reversals are created downstream of obstacles

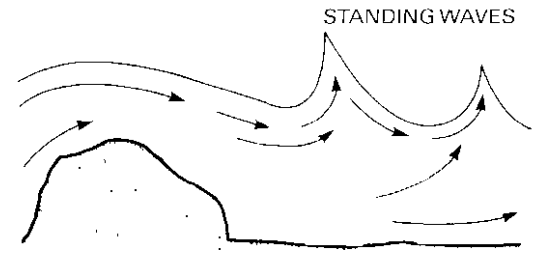

CURRENT AT HIGH WATER

Pillows are covered by deeper water and waves are formed farther downstream.

Holes, Hydraulics, or Reversals. Fast, deep water can drop sharply over an extremely large obstacle into a depression known as a *hole, hydraulic, or reversal*. The volume is not great enough to flow over the ledge or rock and continue downriver in the form of waves. The water gets trapped in the depression below the large rock, recirculates upstream, and continues to roll around within the deep hole.

The more foaming and aerated the water in a hole, the less buoyancy the water will give. A boat will sink down into the hole and have difficulty leaving it. The stronger the flow of recirculating water, the more difficult it will be to paddle through and out of the hole. A large hole with very strong upstream current is called a **keeper**, because it will hold boats in it.

Open-boat paddlers run the risk of swamping in holes, while decked boaters may capsize. Paddlers caught in a hole should swim to either end, where downstream current will help pull them from the hole. An alternative is to catch the current leaving the hole and flowing downstream. Holes deserve the respect of boaters, for a trapped paddler can become disoriented when caught in the recirculating current.

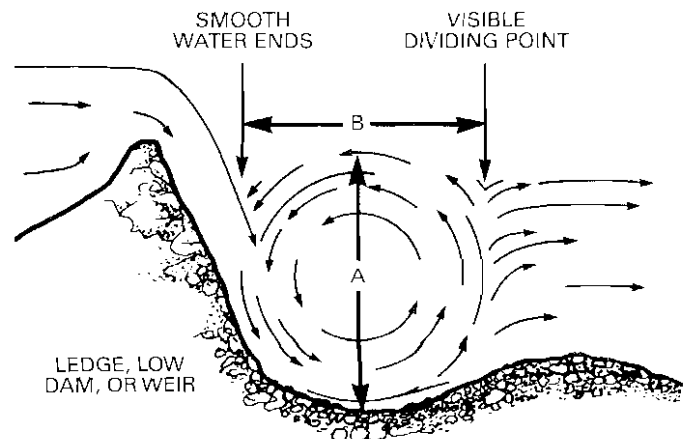

The depth of a hole (A) is often equal to the length of the boiling water (A).

Remember: The length of a hole can be equal to its depth. Holes longer than 4 feet are considered very strong, often dangerous holes.

Man-made obstacles like dams and weirs often have a uniform hole at their base that extends across the entire river width. These extremely regular holes are large and life threatening, because escape from them is limited and often impossible.

BROACHES

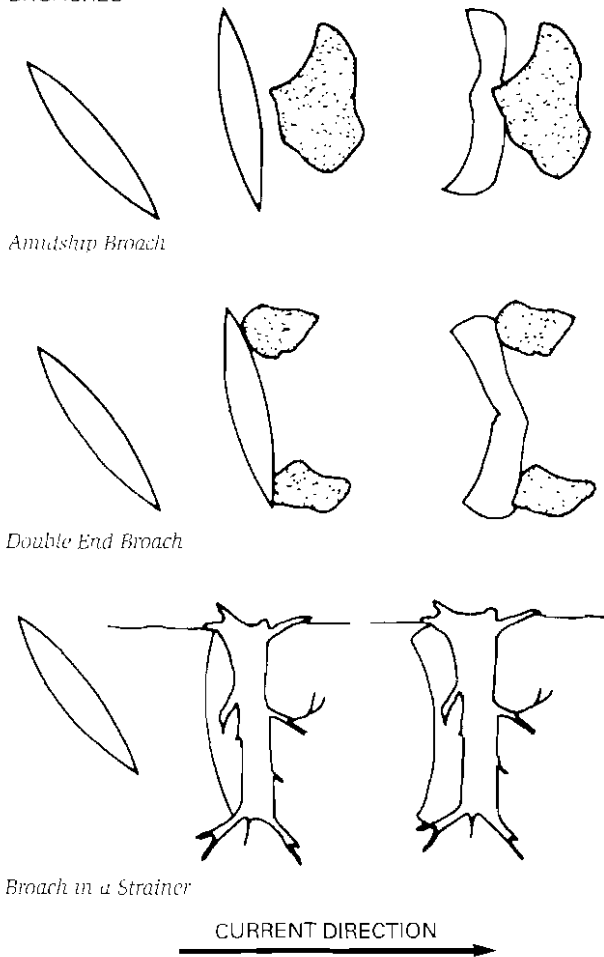

Horizon line. The appearance of a *horizon line*, where only the top of the scenery downstream is evident, is clear evidence of a dam or natural ledge. Other signs are increased noise from falling water and spray or mist from the impact of the drop. Proceed with caution and be prepared to stop to scout the drop.

Shoals. Broken, "dancing" water caused by shallow rocks or a fast drop signal a shoal. Look and listen for shoals in wide valleys where the river spreads out. Ride the open Vs or, on a bend, stay close to the outside of the curve. Be ready to step out if the canoe drags bottom, but keep hold of your craft.

Deep Rock. Quiet water boils or whirls on the surface above a deep rock. Deep rocks present little or no danger, but when the current is slow, rocks will show less in surface boils. In still water, a rock an inch under water won't show at all. That's where the bowman must watch out. In deeper water, you're past the rock when you get into a boil.

Logs and Overhanging Trees. These are generally found on the outside of bends, where undercutting has caused trees to fall into the stream. The current runs through the logs or branches, called "strainers." This is sometimes caused by logs jamming up on an obstruction or shallow place. They are dangerous: Avoid them! Keep the canoe parallel to the current. Portage around or lift the canoe carefully over the area. If you upset, float high and climb into a tree or branches. Don't try to swim through or under logs or overhanging trees. If there is room, back-ferry to the inside of the bend.

Broken Drop. This is caused by several rock ledges and a steep rate of drop. It roars. Look for a broken drop where valley walls are high and the river is narrow. These rapids must be studied from the shore first. Ride the open Vs. Haystacks and rocks may be rough. It may be best for you to portage or pull your canoe from shore with ropes.

Whirlpools and Crosscurrents. Changes in the river current below big drops often cause whirlpools. These are dangerous only in large rivers. When a river curves, the top current moves across the stream, and returns along the bottom. This can drag your canoe into the shore.

Flat Rock. Near the surface in broken water, a flat rock is mean. Look for a smooth, black line with white foaming water—or comparatively still water—just downstream. If you hit, you'll stop, then sit there or swing sideways while the river pours in. These flat rocks also make calm-looking areas in rapids.

Sheer Drop. Always portage this one. If you get caught in it, you'll spill at the lip (by turning and rolling) or at the base. If your canoe stays free, stick with it. If the canoe is caught, leave it and float with your feet downstream, head up. Hang onto the paddle. A sheer drop into deep water can create a "souse hole." This is where the surface water flows upstream and meets the falling water. Anything caught in a souse hole beneath a drop will be forced down by the falling water, then move downstream for a distance under water, come to the surface, and be drawn upstream back into the falling water. This rolling action is deadly and can quickly tear apart a canoe. A person trapped in a

souse hole can sometimes escape by swimming downstream along the bottom of the river. The only smart action is to avoid these death traps.

Heavy Water. Heavy water is caused when many big waves occur just below the place where a narrowing stream bed constricts the water at a drop, when flooding conditions build up water volume, or at a constricted turn in the river. Be careful in heavy water, back-paddling when necessary, and using plenty of paddle-bracing.

RIVER READING RESPONSIBILITIES

As a group, paddlers should develop paddling skills and teamwork that match the rapids to be paddled. Remember to develop the necessary skills gradually and understand that attempts to advance too quickly will compromise safety and enjoyment. Be in good physical and mental condition consistent with the difficulties that may be expected. Make adjustments for any loss of skills resulting from health and fitness difficulties. Explain any health problems to other paddlers in your group prior to beginning the program or trip.

River reading is a two-part process. First, you must select a safe general course (i.e., river right, river left, etc.). Next, you must avoid specific obstacles within that general course.

In a tandem canoe, the general route course is the responsibility of both paddlers. The paddler in the downstream end of the boat is closer to obstacles and is therefore responsible for selecting the immediate course.

This paddler has the responsibility to:

- Choose a route that matches the paddlers' skills.
- Choose a route that allows the paddlers to paddle in control and to rescue themselves. Skills should be sufficient to stop or reach shore before reaching danger.
- Run the course only if you can swim it safely.
- Do not be influenced by peer pressure. If you are frightened, do not make the attempt to run the course. Frequently, you will lack the confidence to execute the correct skills. Remember, the ultimate responsibility for running a rapid rests with the paddlers themselves, regardless of advice they get from others.

Each paddler is responsible for determining individually whether a rapid or river is beyond his or her abilities. Make a constant evaluation of your personal situation, as well as that of the group, voicing concerns and ideas whenever appropriate and following what you believe to

be the safest course of action. Make sure that the appropriate equipment has been selected, including a boat design suited to your personal skills, and appropriate rescue and survival gear. Scout any rapid you feel necessary, and run or portage a scouted river section. It is a personal responsibility to decide whether to pass up a walk-out or take-out opportunity.

Reading the river is helped by:

- Looking down river to the farthest visible point, before the river flows out of sight, to find the best channel and follow it back upriver to the boat
- Repeating the first step constantly
- Avoiding tunnel vision
- Taking action immediately to move the boat into the proper channel
- Communicating a plan of action if paddling a tandem craft
- Being prepared to stop to scout a section (if the river disappears from sight, a horizon line appears, or the water is too chaotic to read)
- Making a personal decision about running a rapid after analyzing route choices
- Being aware of the entire river environment in the event that a rescue must be executed, and knowing the safe shore for a possible self-rescue

GROUP ORGANIZATION

The recommended minimum group size is three boats. Everyone in the group must understand that a boat should not overtake another craft in rapids, and that each craft should give downstream boats enough space so that a descending craft can maneuver around a broached boat.

Each paddler has specific responsibilities in the overall group organization to promote safety.

The **lead boat**

- Sets the pace and keeps track of group members
- Selects the general course and communicates it to other boaters
- Scouts any rapids where a clear route is not visible
- Carries extra equipment and rescue lines in the event that a rapid requires set-up of shoreline rescue assistance

The sweep boat

- Passes other craft only in an emergency
- Carries paddlers who are experienced in rescue and first aid
- Carries spare gear, extra paddles, and first aid equipment
- Keeps the group intact

Other responsibilities include:

- Keeping the group compact to enhance organization
- Maintaining sufficient spacing to avoid collisions
- Keeping the next boat upstream in sight and stopping if it is not visible
- Communicating messages to upstream and downstream boats
- Allowing a descending boat the right of way
- Avoiding crowded drops or eddies where no room exists for another boat
- Judging the difficulty of each rapid and the nature of participation and safety as the trip progresses

Important trip planning factors include:

- The group should select lakes and rivers that have access points where shuttle or emergency vehicles may be parked.
- Additional first aid equipment, dry clothing, and food can be stored at the access points.
- Advance scouting is prudent; check rivers **on the day** of the proposed trip.
- Well-thought-out route choices can help prevent problems.
- On extended trips, group plans and schedules should be filed with a responsible individual who will alert authorities if the group is overdue. Establishing rescue procedure and possible evacuation points can speed a rescue.
- Make sure that someone is responsible for holding on to the car keys.

RESCUE

Never underestimate the power and effects of moving water. A canoe capsized and pinned against a rock in a 5-mile-an-hour current is held in place by more than a ton (2,000 pounds) of force. For most canoes, this is force enough to collapse the craft. If you attempted to stand thigh-deep in a 5-mile-an-hour current, you would be struggling against a force of 100 pounds.

When a rescue becomes necessary, your priorities are (1) people, (2) boats, and (3) equipment. As a first priority, it is the paddler's responsibility to first check himself; then make a visual and verbal check of his partner. Paddlers should reassure each other of their personal safety before attempting to retrieve boats or other equipment.

SELF-RESCUE

Whitewater canoeists are always prepared for a spill. When you do find yourself in the water, move quickly to the upstream end of your canoe and hang on to the gunwale, painter, or grab loop. Get on your back with your feet up and pointed downstream. If you do not move quickly, you could be pinned against a rock by the canoe. Although there are situations where it is wise not to stay with your canoe, in most circumstances the canoe is your best flotation device, making you more visible and a bigger target for rescue efforts, and can provide some protection against rocks or other obstacles.

Use a sidearm stroke and strong kick to head yourself and the canoe into a shore or eddy, if possible. Otherwise, ride the current until you reach a calm stretch, or until a rope is thrown to you. When you get a rope, snub it to the upstream end of the canoe. Do not tie the rope. Hold the snubbed rope to keep it secure, but be ready to release if the rope is swinging you into trouble or if other problems have developed. If you have rope but cannot secure it to the canoe or have to let go of the boat for any reason, let the canoe go and hang on to the rope to swing into shore.

Special circumstances can necessitate releasing the canoe and heading for shore. If the swamped canoe is dragging you toward greater danger, such as falls or strainers, or if you are in extremely cold water with no chance for an early opportunity to get you and the boat to shore, you should go for shore on your own.

If you are capsized in a strong current and lose contact with your canoe, get on your back with your feet up and pointed downstream. Never try to stand in fast water. If your foot becomes snagged or tangled, you will

be quickly pulled under. Put your feet down only in an eddy or slow water, or when the water is too shallow for swimming. Riding the current on your back with your feet up also protects your head and enables you to see where you are going.

SELF-RESCUE

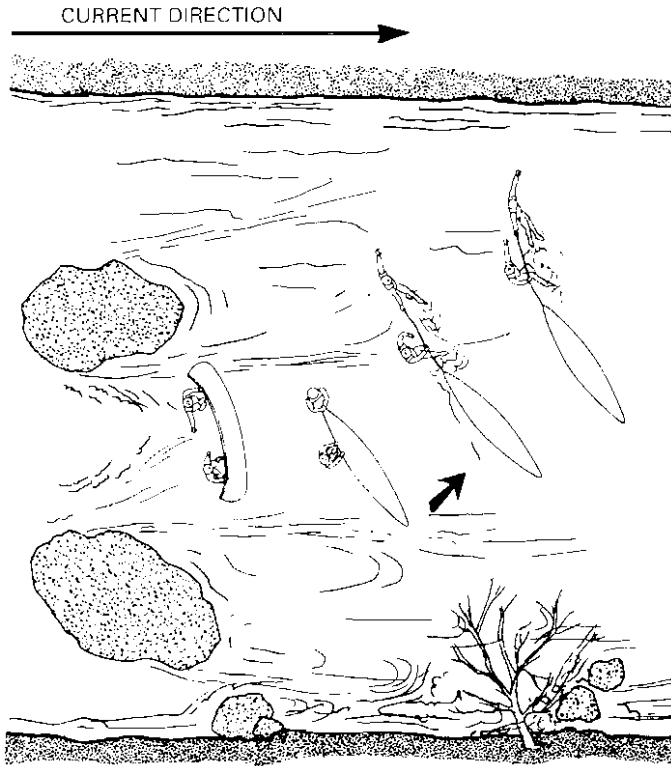

Paddlers should immediately begin an active self-rescue with their paddle and boat if possible. They should move quickly toward the safest shore.

GROUP RESCUE

GENERAL GUIDELINES

1. Alert other paddlers that victims are in the water.
2. Swimmers should initiate self-rescue immediately and be ready to accept assistance from others.
3. Other paddlers assist in a rescue to the best of their ability when it is safe to do so.
4. All paddlers not involved in assisting swimmers should stop as soon as they can safely do so.
5. All paddlers should avoid converging on the rescue scene to prevent additional accidents that may result.

BOAT-ASSISTED RESCUE

In a boat-assisted rescue, the rescue boat assumes an upstream ferry position, while the swimmer takes the grab loop or painter. The rescuers paddle hard to ferry swimmers and the swamped boat to shore. Others can assist the self-rescue by bumping the swamped craft in the amidships area. The additional pushing and bumping action can assist the swimmer in ferrying the swamped boat to shore. To bump the boat, the rescue craft should be positioned amidship of the swamped boat at a perpendicular angle; it should then bump the boat firmly but without changing its ferry angle.

SHORELINE RESCUE

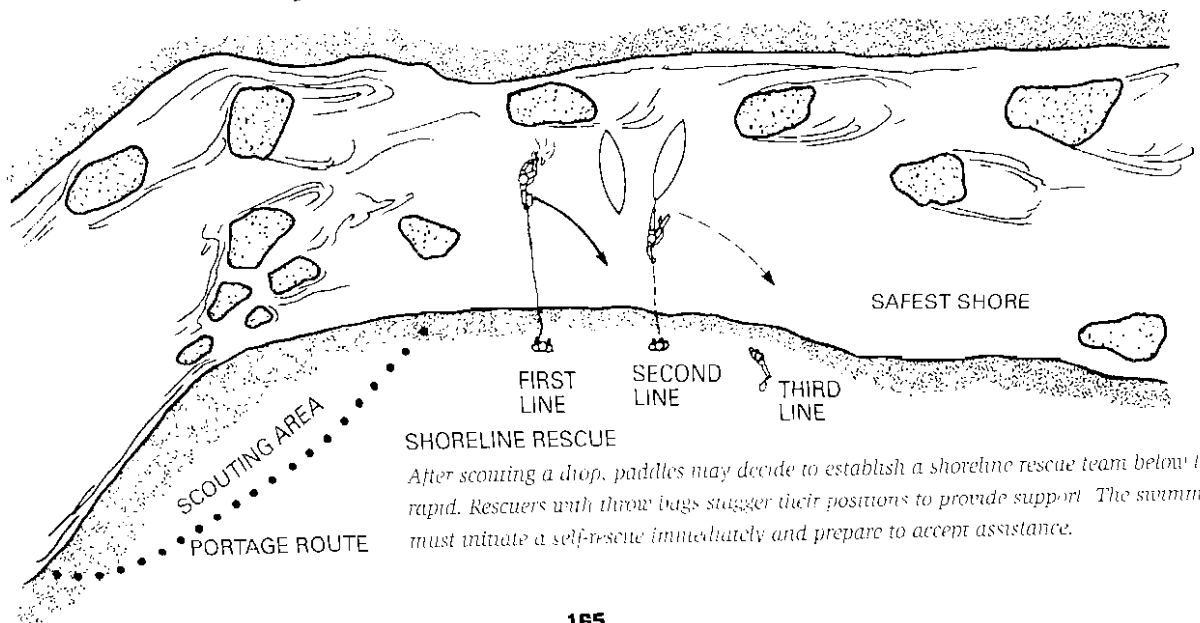

SHORELINE RESCUE

After scouting a drop, paddlers may decide to establish a shoreline rescue team below the rapid. Rescuers with throw bags stagger their positions to provide support. The swimmer must initiate a self-rescue immediately and prepare to accept assistance.

SHORELINE RESCUE

After scouting a drop, paddlers may decide to establish a shoreline rescue team below the rapid. On difficult rapids, have people with throw ropes positioned at several vantage points downstream before anyone begins the run. The ideal location for a shoreline rescue is below the rapid in a section of the river that is relatively free of obstacles. The rescuer should then:

1. Get the swimmer's attention.
2. Yell "Rope" once the line is thrown.
3. Aim for the swimmer or just downstream of the person, and throw past him. Use an underhand swing.
4. Prepare to swing the swimmer into shore or change the swimmer's position in the river by moving along the shore, pulling him along.
5. Have second and third lines thrown if the first one fails.

In a shore-assisted rescue, the swimmer should hold the throw line over his shoulder and stay on his back while being pendulumed to shore. Rescuers should not wrap or coil line around any part of their bodies. If the swimmer is unable to hold the line, the rescuer should move with the line to release the pressure until he is able to find the next location to swing the paddler to shore.

BOAT-ASSISTED RESCUE

Decked boaters who are unable to perform an Eskimo roll can use the bow of another craft to roll up. Both hands should be placed above the water, sweeping back and forth, feeling for the rescue craft. The rescue craft moves into a position so that the paddler can grab the bow and roll up. If a decked boater has to perform a wet exit, self-rescue should be initiated.

BOAT-OVER-BOAT RESCUE

In a boat-over-boat rescue, the overturned boat is lifted across the gunwales of the rescue boat, with the swimmers assisting if possible. The boat is then rolled upright, with the rescuers staying low at all times to maintain their balance. The boat is then slid into the water and positioned next to the rescue boat. A catamaran, formed by positioning the two boats together, helps to stabilize the empty boat while the swimmers re-enter it.

BOAT-OVER-BOAT RESCUE

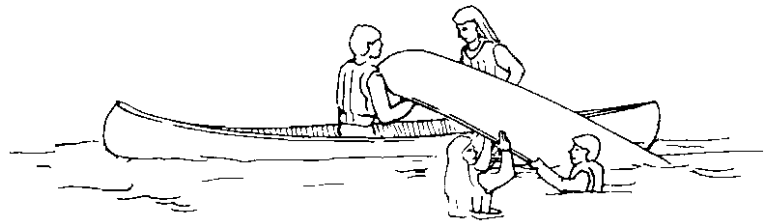

1. Lift the overturned boat across the gunwales of the rescue boat. Swimmers should help if possible.

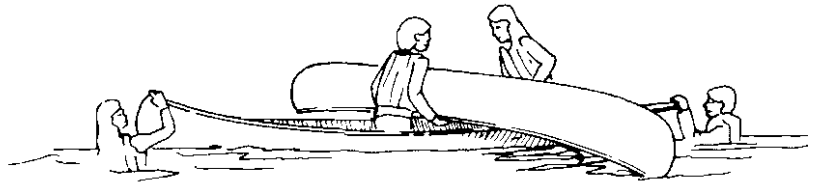

2. The rescuers roll the empty boat upright and stay low to maintain their balance.
3. Rescuers slide the upright boat into the water and position it next to the rescue boat. A catamaran helps to stabilize the empty boat while swimmers re-enter it.

RESOURCES

BOOKS

Boy Scout Handbook. BSA, 1990.

Canoeing and Kayaking Instruction Manual. by Laurie Gullian. American Canoe Association, 1987.

Fieldbook. BSA, 1984.

Recreational Whitewater, by Thomas Foster. Leisure Enterprises, 1981.

River Rescue, by Les Bechdel and Slim Ray. Appalachian Mountain Club, 1985.

Whitewater merit badge pamphlet. BSA, 1989.

The Whitewater River Book, by Ron Watters. Pacific Search Press, 1982.

ORGANIZATIONS

American Canoe Association Book Service
Box 1190
Newington, VA 22122
Instructional books, paddling guides, and maps.

American Canoe Association Film Library
Box 1190
Newington, VA 22122
Instructional and safety films.

American Red Cross
(Local chapters as well as the national office)
17th and D Streets NW
Washington, DC 20006.

Gravity Sports Films, Inc
2171 East 3300 South
Salt Lake City, UT 84109
Instructional and travelogue films.

National Safety Network
P.O. Box 186
Bellefontaine, OH 43311
Safety in recreation information and statistics.

Ohio Department of Natural Resources
Fountain Square
Building D-3
Columbus, OH 43224-1387
Rescue training programs and manuals.

ACKNOWLEDGMENT

The Boy Scouts of America gratefully acknowledges the American Canoe Association for the use of its material in the preparation of this chapter. Much of the material and artwork has been adapted from its publications.

NOTES

VARSDTY TEAM PROGRAM FEATURES

A GUIDE TO TEAM PROGRAM PLANNING

VOLUME I

Backpacking
Basketball
Bowling
Canoe Camping
Caving
Cross-Country Skiing
Cycling
Discovering America
Fishing

VOLUME II

Freestyle Biking
Frontiersman
Mechanics
Operation On-Target
Orienteering
Rock Climbing and Rappelling
Roller Hockey
Shooting Sports
Snow Camping

VOLUME III

Soccer
Softball
Survival
Swimming
Tennis
Triathlon
Volleyball
Waterskiing
Whitewater Canoeing

#34839



7 30176 34839 1



BOY SCOUTS OF AMERICA

1305 West Marlin Lane

PO Box 160079

Dallas, TX 75216-2079

<http://www.scouting.org>